

Ring Compressor

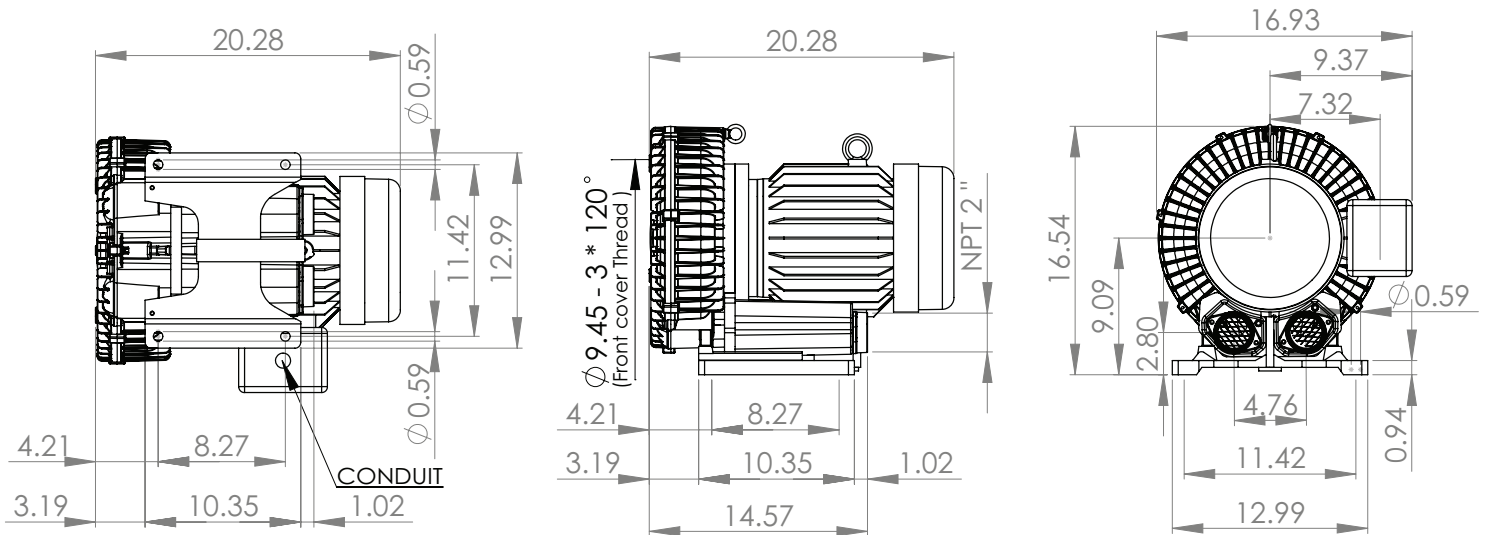

Unit: inches

Specifications

Model	EXV500-7W		
Phase	3	Max. Pressure (in. H ₂ O)	170
Voltage	230/460	Max. Vacuum (in. H ₂ O)	126
Frequency (Hz)	60	Max. Airflow (CFM)	194
Rated Output (HP)	5.0	Noise Level dB (A)	84
Rated Current (Amps)	11.6/5.8	Weight (lbs.)	183

Pressure

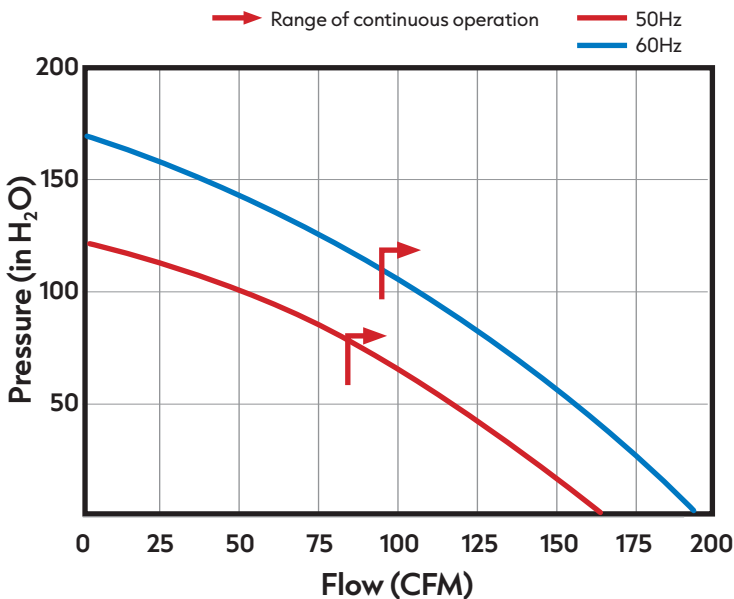

Vacuum

