

# DIFFERENTIAL PRESSURE TRANSMITTER

**DATA SHEET**
**FKC...6**

The FKC model of the FCX-A IV series of pressure transmitters accurately measures a differential pressure, a liquid level or a flow rate and transmits a proportional 4-20 mA output signal. The transmitter uses a unique microcapacitive silicon sensor in combination with a state-of-the-art digital signal processing to provide exceptional performances in terms of accuracy and stability.

FCX-A IV series of pressure transmitters comply with Safety Integrity Level 2 or 3 according to IEC 61508 and IEC 61511 standards.



## FEATURES

### 1. High accuracy up to $\pm 0.04\%$

Fuji Electric's micro-capacitive silicon sensor provides in standard  $\pm 0,065\%$  accuracy for all elevated or suppressed calibration ranges without additional adjustments.  $\pm 0.04\%$  accuracy is available in option.

### 2. Minimum inventory and design

Electronic parts, local indicator and electronic housing are interchangeable among all FCX-A IV transmitters.

### 3. Minimum environmental influence

The Advanced Floating Cell technology provides a high immunity against temperature variations, static pressure and overpressure commonly found in the process industry and substantially reduces the overall measurement error.

### 4. HART 7 communication protocols

FCX-A IV series of pressure transmitters can communicate using the universal HART communication protocol.

By the use of the HART Device Description files, HART compatible devices can communicate with any FCX-A IV transmitter.

### 5. Application flexibility

Various options are available to address most of the process industry applications, including:

- Full range of hazardous area approvals
- Built-in RFI filter and lightning arrester
- 5 digits local display with engineering units
- Stainless steel electronics housing
- Wide selection of wetted part materials

### 6. Programmable output Linearization Function

The output signal can be linearized using up to 14 pairpoints.

### 7. Burnout current flexibility

The burnout current value can be adjusted in the ranges of [3.4 ; 3.8] and [20.8 ; 22.5] mA and can be compliant with NAMUR NE43 recommendations.

### 8. Contactless local adjustment

An optional local configurator with 3 magnetic switches allows to configure the transmitter without opening the indicator cover (flameproof approvals for hazardous locations) The Magnetic pen is required to enable the 3 magnetic switches (Please refer to ACCESSORIES).

## SPECIFICATIONS

### Functional specifications

#### Type:

FKC: Smart, 4-20mA with HART communication protocol

#### Service:

Liquid, gas, or vapour

#### Static pressure, span, and range limits:

| Model   | Static pressure<br>MPa {bar}  | Span limits kPa<br>{m bar} |                   | Range limits<br>kPa {m bar}            |
|---------|-------------------------------|----------------------------|-------------------|--|
|         |                               | Min.                       | Max.              |  |
| FKC□11  | -0.1 to + 3.2<br>{-1 to + 32} | 0.1<br>{1}                 | 1<br>{10}         | $\pm 1$<br>{ $\pm 10$ }                |
| FKC□22  | -0.1 to + 10<br>{-1 to + 100} | 0.1<br>{1}                 | 6<br>{60}         | $\pm 6$<br>{ $\pm 60$ }                |
| FKC□33  | -0.1 to + 16<br>{-1 to + 160} | 0.32<br>{3.2}              | 32<br>{320}       | $\pm 32$<br>{ $\pm 320$ }              |
| FKC□35  | -0.1 to + 16<br>{-1 to + 160} | 1.3<br>{13}                | 130<br>{1300}     | $\pm 130$<br>{ $\pm 1300$ }            |
| FKC□36  | -0.1 to + 16<br>{-1 to + 160} | 5<br>{50}                  | 500<br>{5000}     | $\pm 500$<br>{ $\pm 5000$ }            |
| FKC□38  | -0.1 to + 16<br>{-1 to + 160} | 30<br>{300}                | 3000<br>{30000}   | $\pm 3000$<br>{ $\pm 30000$ }          |
| FKC□43  | -0.1 to + 42<br>{-1 to + 420} | 0.32<br>{3.2}              | 32<br>{320}       | $\pm 32$<br>{ $\pm 320$ }              |
| FKC□45  | -0.1 to + 42<br>{-1 to + 420} | 1.3<br>{13}                | 130<br>{1300}     | $\pm 130$<br>{ $\pm 1300$ }            |
| FKC□46  | -0.1 to + 42<br>{-1 to + 420} | 5<br>{50}                  | 500<br>{5000}     | $\pm 500$<br>{ $\pm 5000$ }            |
| FKC□48  | -0.1 to + 30<br>{-1 to + 300} | 30<br>{300}                | 3000<br>{30000}   | $\pm 3000$<br>{ $\pm 30000$ }          |
| FKC□49* | -0.1 to + 30<br>{-1 to + 300} | 500<br>{5000}              | 20000<br>{200000} | {+20000, -10000}<br>{+200000, -100000} |

Note: Span higher than 1/10 of the URL is recommended for optimal accuracy.

Important: For FKC#49, the maximum possible overload pressure on LP side must be  $\leq 100$  bar. The accuracy is not guaranteed when used at negative DP.

#### Lower limit of static pressure (vacuum limit):

Silicone fill sensor: See Fig. 1

Fluorinated fill sensor:

66kPa abs (500mHg abs) at temperature -20 to 60°C

#### Over range limit:

To maximum static pressure limit

**Output signal:**

4-20 mA (linear or square root) with HART communication protocol

**Power supply:**

10.5 to 45 V DC at transmitter terminals.  
10.5 to 32 V DC with the optional arrester.

Refer to hazardous location table for specific limitations

**Load limitations:** see figure below

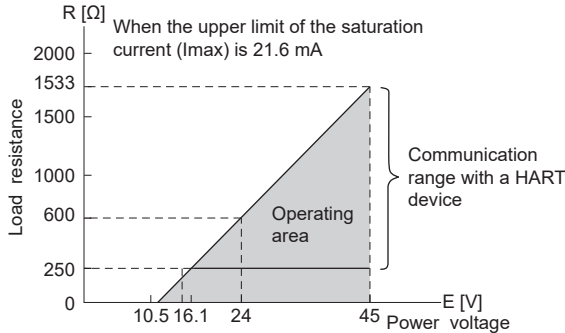

Note 1 : The load resistance varies with the upper limit of the saturation current [I max]

$$R [\Omega] = \frac{E [V]-10.5}{(I \text{ max [mA]}+0.9)\times 10^{-3}}$$

Note 2 : For communication with a HART device, a minimum load of 250 Ω is required.

**Hazardous locations:**

| Marking (Digit 10 <sup>th</sup> ) | Protection type               |   |                          |                     |
|-----------------------------------|-------------------------------|---|--------------------------|---------------------|
| ATEX                              | K                             | Intrinsic Safety "i"                                      |                          |                     |
|                                   |                               | Ex II1 G/D  |                          |                     |
|                                   |                               | Ex ia IIC T4 Ga (Ta: -40°C to +60°C)                      |                          |                     |
|                                   |                               | Ex ia IIC T5 Ga (Ta: -40°C to +50°C)                      |                          |                     |
|                                   |                               | Ex ia IIIC T <sub>200</sub> 135°C Da (Ta: -40°C to +60°C) |                          |                     |
|                                   |                               | Ex ia IIIC T <sub>200</sub> 100°C Da (Ta: -40°C to +50°C) |                          |                     |
|                                   |                               | Ui = 28Vdc, li = 110mA, Pi = 0.77W                        |                          |                     |
|                                   |                               | Ci = 14.9nF (without optional Arrester)                   |                          |                     |
|                                   |                               | Ci = 26.0nF (with optional Arrester)                      |                          |                     |
|                                   |                               | Li = 0.181mH  |                          |                     |
|                                   |                               | IP66/67   |                          |                     |
|                                   |                               | X   | Flameproof Enclosure "d" |                     |
|                                   | Ex II2 G                      |   |                          |                     |
|                                   | Ex db IIC T6... T4 Gb         |   |                          |                     |
|                                   | Temperature class             |   | Ambient temperature      | Process temperature |
|                                   | T6                            |   | -40°C to +65°C           | -40°C to +85°C      |
|                                   | T5                            |   | -40°C to +85°C           | -40°C to +100°C     |
|                                   | IP66/67                       |   |                          |                     |
| M                                 | Combination (K) + (X) pending |   |                          |                     |
| IECEx                             | T                             | Intrinsic Safety "i"                                      |                          |                     |
|                                   |                               | Ex ia IIC T4 Ga (Ta: -40°C to +60°C)                      |                          |                     |
|                                   |                               | Ex ia IIC T5 Ga (Ta: -40°C to +50°C)                      |                          |                     |
|                                   |                               | Ex ia IIIC T <sub>200</sub> 135°C Da (Ta: -40°C to +60°C) |                          |                     |
|                                   |                               | Ex ia IIIC T <sub>200</sub> 100°C Da (Ta: -40°C to +50°C) |                          |                     |
|                                   |                               | Ui = 28Vdc, li = 110mA, Pi = 0.77W                        |                          |                     |
|                                   |                               | Ci = 14.9nF (without optional Arrester)                   |                          |                     |
|                                   |                               | Ci = 26.0nF (with optional Arrester)                      |                          |                     |
|                                   |                               | Li = 0.181mH  |                          |                     |
|                                   |                               | IP66/67   |                          |                     |
|                                   |                               | R   | Flameproof Enclosure "d" |                     |
|                                   |                               |   | Ex db IIC T6... T4 Gb    |                     |
|                                   | Temperature class             |   | Ambient temperature      | Process temperature |
|                                   | T6                            |   | -40°C to +65°C           | -40°C to +85°C      |
|                                   | T5                            |   | -40°C to +85°C           | -40°C to +100°C     |
|                                   | IP66/67                       |   |                          |                     |
|                                   | N                             | Combination (T) + (R) pending                             |                          |                     |

| cCSAus pending | J | Intrinsic Safety/Non-Incendive  |                       |
|----------------|---|---|-----------------------|
|                |   | IS Class I Division 1 Groups ABCD Ex ia<br>Class II Groups EFG, Class III<br>NI Class I Division 2 Groups ABCD<br>T4 (-40°C ≤ Ta ≤ +60°C)<br>T5 (-40°C ≤ Ta ≤ +50°C)<br>Ui = 28Vdc, li = 110mA, Pi = 0.77W<br>Ci = 14.9nF (without optional Arrester)<br>Ci = 26.0nF (with optional Arrester)<br>Li = 0.181mH |                       |
| E              |   | Flameproof Enclosure  |                       |
|                |   | XP Class I Division 1 Groups CD<br>Class II Groups EFG, Class III<br>T6 (-40°C ≤ Ta ≤ +65°C)<br>T5 (-40°C ≤ Ta ≤ +85°C)<br>T4 (-40°C ≤ Ta ≤ +60°C)<br>Vmax = 45Vdc  |                       |
|                |   | L   | Combination (J) + (E) |

**Configuration:**

Configuration of the FCX-A IV series of pressure transmitters can be carried out by either using a HART device or the optional local configurator.

A third party HART device can be used in combination with Fuji Electric FCX-A IV HART Device Description files. (<https://fieldcommgroup.org>).

| Functions                     | HART Protocol |     | Local configurator |     |
|-------------------------------|---------------|-----|--------------------|-----|
|                               | Display       | Set | Display            | Set |
| Tag Nb                        | ✓             | ✓   | ✓                  | ✓   |
| Model Nb                      | ✓             | ✓   | ✓                  | ✓   |
| Serial Nb & Software revision | ✓             | —   | ✓                  | —   |
| Engineering units             | ✓             | ✓   | ✓                  | ✓   |
| Upper Range Value             | ✓             | —   | ✓                  | —   |
| Measuring Range               | ✓             | ✓   | ✓                  | ✓   |
| Damping                       | ✓             | ✓   | ✓                  | ✓   |
| Output signal type            | Linear        | ✓   | ✓                  | ✓   |
|                               | Square Root   | ✓   | ✓                  | ✓   |
| Burnout current               | ✓             | ✓   | ✓                  | ✓   |
| Calibration                   | ✓             | ✓   | ✓                  | ✓   |
| Output Adjust                 | —             | ✓   | —                  | ✓   |
| Measuring Value               | ✓             | —   | ✓                  | —   |
| Self Diagnosis                | ✓             | —   | ✓                  | —   |
| External Adj Screw Lock       | ✓             | ✓   | ✓                  | ✓   |
| Transmitter Display           | ✓             | ✓   | ✓                  | ✓   |
| Linearization                 | ✓             | ✓   | ✓                  | ✓   |
| Rerange                       | ✓             | ✓   | ✓                  | ✓   |
| Saturation Current            | ✓             | ✓   | ✓                  | ✓   |
| Write Protect                 | ✓             | ✓   | ✓                  | ✓   |
| History                       |               |     |                    |     |
| – Calibration History         | ✓             | ✓   | ✓                  | ✓   |
| – Ambient T° History          | ✓             | —   | ✓                  | —   |

**Zero and span adjustment:**

Zero and span are remotely adjustable by a HART device or locally by the local configurator or the external adjustment screw.

**Damping:**

The damping time constant can be adjusted within the range of [0.04 to 32] seconds.

**Zero elevation / suppression:**

Zero can be adjusted within the range of ±100% of the URL of the sensor.

**Normal / reverse action:**

Selectable by range setting.

**Local indicator:**

Optional 5-digits LCD unit or local configurator with 3 magnetic switches and push-buttons.

A magnetic pen is required to enable this local configurator function.

(Please refer to the ACCESSORIES section.)

**Saturation currents:**

Lower limit: 3.6 to 4.0mA, Default value: 3.8mA

Upper limit: 20.0 to 21.6mA, Default value: 20.8mA

**Burnout direction and output current:**

In the self-diagnostic functions detect a transmitter failure, the burnout function will drive the output signal to either "Output Hold", "Output Overscale" or "Output Underscale" modes.

**When "Output Hold":**

The output signal is held as the latest value just before the failure happens.

**When "Output Overscale":**

The output signal is set within the range of [20.8 to 22.5] mA, Default value: 21.6mA

**When "Output Underscale":**

The output signal is set within the range of [3.4 to 3.8] mA, Default value: 3.6mA

**IEC 61511 considerations:**

For safety applications, the "Output Hold" MUST NOT be used. Only "Output Overscale" and "Output Underscale" must be used to clearly notify a "failure" state.

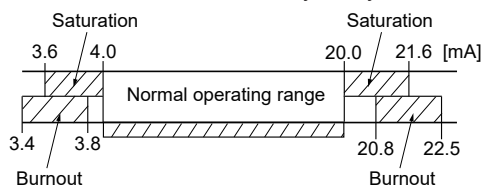

**Loop-check / fixed output current:**

The transmitter can be configured to provide a constant output signal from 3.4 to 22.5 mA.

**Low flow cut-off:**

The output signal is proportional to  $\sqrt{}$  differential pressure between low flow cut-off and the measuring range. Between zero and low flow cut-off, the output signal is programmable to zero or linear between 0 and 20% of the flow.

**Temperature limit:**

Ambient:

-40 to +85°C

-20 to +80°C (with optional LCD unit)

-40 to +60°C (with optional arrester)

Please refer to the hazardous locations table for ambient temperature limitations according to the standard and type of protection.

Process: -40 to +120°C for silicone fill sensor

-20 to +80°C for fluorinated oil fill sensor

Storage: -40 to +90°C

**Humidity limit:**

0 to 100% RH (Relative Humidity)

**Performance specifications for linear output**

Reference conditions, silicone filling oil, SS 316L isolating diaphragms, 4 to 20 mA analog output in linear mode.

**Accuracy rating:**

(including linearity, hysteresis, and repeatability)

**Max span: 32 kPa to 3000 kPa models:**

For spans > 1/10 of URL:

$\pm 0.065\%$  of span or  $\pm 0.04\%$  of span (optional)

For spans < 1/10 of URL:

$\pm (0.015 + 0.005 \times \frac{URL}{Span})$  % of span

**Max span 20 MPa model:**

For spans  $\geq 5$  MPa:  $\pm 0.1\%$  of span

For spans < 5 MPa:

$\pm (0.05 + 0.05 \times \frac{5MPa}{Span})$  % of span

**Max span 1 kPa and 6 kPa models:**

For spans greater than 1/10 of URL:  $\pm 0.1\%$  of span

For spans below 1/10 of URL:

$\pm (0.05 + 0.005 \times \frac{URL}{Span})$  % of span

**Stability:**

$\pm 0.1\%$  of the URL for 10 years for 6th digit code 3, 5, 6, 8 and 9.

**Temperature effect:**

Effects per 28°C changewithin the range of -40°C and +85°C

| Range code (6th digit in the model code)   | Zero shift (% of span)                    | Total effect (% of span)                  |
|--|---|---|
| "1"/1 kPa {10 mbar}<br>"2"/6 kPa {60 mbar}   | $\pm (0.125 + 0.1 \frac{URL}{Span})$ %    | $\pm (0.15 + 0.1 \frac{URL}{Span})$ %     |
| "3"/32kPa {320mbar}<br>"5"/130kPa {1300mbar}<br>"6"/500kPa {5000mbar}<br>"8"/3000 kPa {30000mbar}<br>"9"/20000kPa {200000mbar} | $\pm (0.075 + 0.0125 \frac{URL}{Span})$ % | $\pm (0.095 + 0.0125 \frac{URL}{Span})$ % |

Double the effects for material code (7th digit in model code) "H", "M", "T"

**Static pressure effect:**

| Static pressure code (5th digit in the model code)           | Zero shift (% of URL)  |
|--|--|
| "1" / 1 kPa {10 mbar} sensor<br>"2" / 6 kPa {60 mbar} sensor | $\pm 0.2\%$ / 3.2 MPa {32 bar}<br>$\pm 0.2\%$ / 10 MPa {100 bar} |
| "3"  | $\pm 0.035\%$ / 6.9 MPa {69 bar}                                 |
| "4"  | $\pm 0.2\%$ / 6.9 MPa {69 bar} FKCC49                            |

Double the effects for material code (7th digit in model code) "H", "M", "T"

**Overrange effect:**

| Static pressure code (5th digit in the model code)         | Zero shift (% of URL)  |
|--|--|
| "1" / 1kPa {10m bar} sensor<br>"2" / 6kPa {60m bar} sensor | $\pm 0.2\%$ / 3.2MPa {32bar}<br>$\pm 0.2\%$ / 10MPa {100bar} |
| "3"  | $\pm 0.1\%$ / 16 MPa {160 bar} FKCC35,36,38                  |
| "3"  | $\pm 0.15\%$ / 16 MPa {160 bar} FKCC33                       |
| "4"  | $\pm 0.25\%$ / 42 MPa {420 bar} FKCC43,45,46,48              |
| "4"  | $\pm 0.2\%$ / 10 MPa {100 bar} FKCC49                        |

Double the effects for material code (7th digit in model code) "H", "M", "T"

**Performance specifications for square root output****Accuracy rating:**

| Output     | Span           |                                  |
|------------|----------------|----------------------------------|
|            | over 0.1 × URL | below 0.1 × URL                  |
| 50 to 100% | ±0.065%        | ±(0.015+0.005 × URL/Span)%       |
| 20 to 50%  | ±0.163%        | ±2.5 × (0.015+0.005 × URL/Span)% |
| 10 to 20%  | ±0.325%        | ±5 × (0.015+0.005 × URL/Span)%   |

**Max span 1 kPa and 6kPa models:**

| Output     | Accuracy |
|------------|----------|
| 50 to 100% | ±0.1%    |
| 20 to 50%  | ±0.25%   |
| 10 to 20%  | ±0.5%    |

**Temperature effect:**

Effects per 28°C change within the range of -40°C and +85°C

| Range code      | Shift at 20% output point  |
|-----------------|--|
| "1" and "2"     | $\pm \left( 0.375 + 0.25 \frac{\text{URL}}{\text{Span}} \right) \% / 28^\circ\text{C}$   |
| "3" through "9" | $\pm \left( 0.24 + 0.03125 \frac{\text{URL}}{\text{Span}} \right) \% / 28^\circ\text{C}$ |

**Common performance specifications for both output modes****Supply voltage effect:**

Less than 0.005% of calibrated span per 1 V

**Update rate:**

40 msec

**Electromagnetic compatibility:**

FCX-A IV transmitters are in accordance with the following harmonized standards:

**EN 61326-1**

**EN 61326-2-3**

**EN 61326-3-1**

**RFI effect:**

< 0,2% of the URL for the frequencies from 20 up to 1000 MHz with an electrical strength of 10 V/m and housing covers in place. (Classification: 2-abc: 0.2% of span according SAMA PMC 33.1).

**Response time:** (63.3% of output signal without damping)

| Range code<br>(6th digit in code symbols) | Time constant<br>(at 23°C) | Dead time      |
|---|----------------------------|----------------|
| "1"                                       | 0.33 s                     | about 0.06 sec |
| "2"                                       | 0.3 s                      |                |
| "3"                                       | 0.12 s                     |                |
| "5" through "8"                           | 0.08 s                     |                |

Response time = time constant + dead time

**Mounting position effect:**

Zero shift:

Less than 0.12kPa (1.2mbar) for a 10° tilt in any position.

This error can be corrected by adjusting zero.

(Double the effect for fluorinated fill sensors.)

No effect on span.

**Vibration effect:**

< ±0.25% of URL

Frequency 10 to 150 Hz, acceleration 29.4 m/sec<sup>2</sup>.

**Dielectric strength:**

500 V AC, 50/60Hz 1 min., between circuit and earth (except with the optional arrester)

**Insulation resistance:**

More than 100 MΩ at 500 V DC.

**Internal resistance for external field indicator:**

12 Ω max. (connected to test terminal CK+ and CK-)

**Pressure equipment directive (PED) 2014/68/EU:**

According to Article 4.3

**PHYSICAL SPECIFICATIONS****Electrical conduit connections:**

1/2"-14 NPT, Pg13.5 or M20 × 1.5

**Process connections:**

Standard: 1/4"-18 NPT meets DIN 19213.

Option: 1/2"-14 NPT with oval flanges

**Process-wetted parts material:**

|   | Material code<br>(7th digit) | Process<br>cover | Diaphragm                 | Wetted<br>sensor body | Vent/<br>drain |
|---|------------------------------|------------------|---------------------------|-----------------------|----------------|
| V | Ranges 1 & 2                 | SS 316L          | SS 316L                   | SS 316LN              | SS 316L        |
|   | Ranges 3 to 8                | SS 316L          | SS 316L                   | SS 316L               | SS 316L        |
|   | W                            | SS 316L          | Hastelloy-C               | SS 316L               | SS 316L        |
|   | H                            | SS 316L          | Hastelloy-C               | Hastelloy-C           | SS 316L        |
|   | J                            | SS 316L          | SS 316L +<br>Gold coating | SS 316L               | SS 316L        |
|   | M                            | SS 316L          | Monel                     | Monel lining          | SS 316L        |
|   | T                            | SS 316L          | Tantalum                  | Tantalum lining       | SS 316L        |

Remark: Gasket : Viton o-ring or PTFE square section gasket.

Availability of above material design depends on ranges and static pressure according material codes V, H, M and T.

Refer to the "Model code symbols".

**Non-wetted parts material:**

Electronics housing:

Low copper die-cast aluminum alloy finished with polyester coating (standard), or SS 316 (option).

Bolts an nuts:

Carbon steel (up to 42 MPa MWP), SS 316L (up to 16 MPa MWP) or SS 660 (up to 42 MPa MWP)

Filling fluid:

Silicone oil (standard) or fluorinated oil (option)

Mounting bracket: SS 316L

**Environmental protection:**

IEC IP66 & IP67 and Type 4X

**Mounting:**

DN50(2") pipe or wall mounting using the mounting bracket.

Direct to process cover connections without the mounting bracket.

**Mass{weight}:**

Transmitter approx.: 3.5 kg without options.

Add: 0.2 kg for indicator

0.5 kg for mounting bracket

2.0 kg for stainless steel housing (option)

## OPTIONAL FEATURES

### Local indicator:

An optional 5 digit indicator with engineering units is available.

A local configurator can be carried out using the 3 magnetic switches and push-buttons.

A separately ordered magnet pen is required for adjustment using the magnetic switches.

See the accessories section.

### Arrester

A built-in arrester protects the electronics from lightning surges.

Lightning surge immunity:  $\pm 4$  kV ( $1.2 \times 50 \mu\text{s}$ )

### Oxygen service:

Special cleaning procedures are applied during the manufacturing process to maintain oil free all process wetted part. The filling fluid is fluorinated oil.

### Chlorine service:

Same procedures and filling fluid as for oxygen service.

### Degreasing:

Process-wetted parts are cleaned and the filling fluid is standard silicone oil. Not for use with oxygen or chlorine presence.

### NACE specification:

Metallic materials for all pressure boundary parts comply with NACE MR 0175/ISO 15156.

SS 660 bolts and nuts comply with NACE MR 0175/ISO 15156.

### Optional tag plate:

An extra stainless steel tag plate with customer tag data is wired to the transmitter.

## ACCESSORIES

### Oval flange:

Converts the process connection to 1/2"-14 NPT.

### Manifolds:

Stainless Steel 316L, 16 MPa or 42 MPa pressure rating

### Magnet pen:

To be used with the 3 push-buttons optional indicators.  
Order number = ZZP\*TQ507742C1

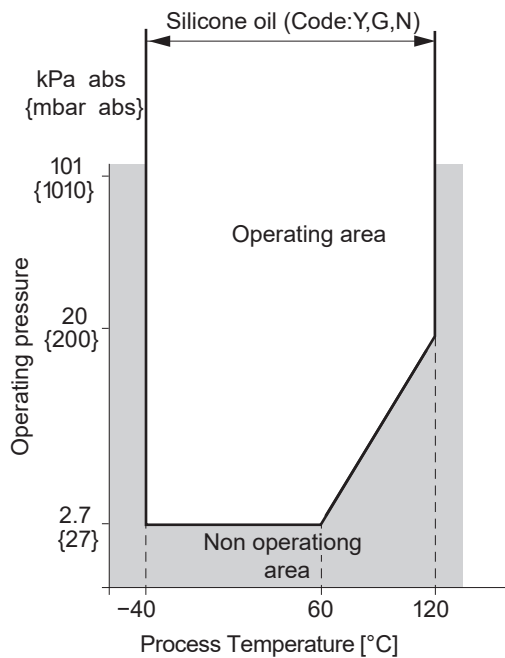
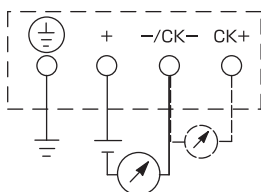

Fig. 1 Relation between process temperature and operating pressure

## CONNECTION DIAGRAM



# MODEL CODE SYMBOLS

| 1 |   | 2 |  | 3 |  | 4 |  | 5 |  | 6 |  | 7 |  | 8 |  | 9 |  | 10 |  | 11 |  | 12 |  | 13 |  | 14 |  | 15 |  | 16 |  | DESCRIPTION   |  |   |  |  |  |                     |  |   |  |                         |  |  |  |  |  |  |  |  |  |  |  |
|---|---|---|--|---|--|---|--|---|--|---|--|---|--|---|--|---|--|----|--|----|--|----|--|----|--|----|--|----|--|----|--|---|--|---|--|--|--|---------------------|--|---|--|-------------------------|--|--|--|--|--|--|--|--|--|--|--|
| F | K | C |  |   |  |   |  |   |  |   |  |   |  |   |  |   |  |    |  |    |  |    |  |    |  |    |  |    |  |    |  |   |  |   |  |  |  |                     |  |   |  |                         |  |  |  |  |  |  |  |  |  |  |  |
|   |   |   |  |   |  |   |  |   |  |   |  |   |  |   |  |   |  |    |  |    |  |    |  |    |  |    |  |    |  |    |  | Type  |  | Differential pressure transmitter - Smart, 4-20 mA with HART communication protocol |  |  |  |                     |  |   |  |                         |  |  |  |  |  |  |  |  |  |  |  |
|   |   |   |  |   |  |   |  |   |  |   |  |   |  |   |  |   |  |    |  |    |  |    |  |    |  |    |  |    |  |    |  | Connections   |  |   |  |  |  |                     |  |   |  |                         |  |  |  |  |  |  |  |  |  |  |  |
|   |   |   |  |   |  |   |  |   |  |   |  |   |  |   |  |   |  |    |  |    |  |    |  |    |  |    |  |    |  |    |  | Process Connection                                    |  | Oval flange threading   |  | Conduit connection   |  | Amplifier case type |  | Direction of process connection                       |  |                         |  |  |  |  |  |  |  |  |  |  |  |
|   |   |   |  |   |  |   |  |   |  |   |  |   |  |   |  |   |  |    |  |    |  |    |  |    |  |    |  |    |  |    |  | 1/4-18 NPT  |  | 7/16-20 UNF   |  | 1/2-14 NPT   |  | "L" Shape           |  | Standard  |  |                         |  |  |  |  |  |  |  |  |  |  |  |
|   |   |   |  |   |  |   |  |   |  |   |  |   |  |   |  |   |  |    |  |    |  |    |  |    |  |    |  |    |  |    |  | (*1)  |  | M10   |  | M20x1.5  |  |                     |  |   |  |                         |  |  |  |  |  |  |  |  |  |  |  |
|   |   |   |  |   |  |   |  |   |  |   |  |   |  |   |  |   |  |    |  |    |  |    |  |    |  |    |  |    |  |    |  |   |  |   |  | Pg13.5   |  |                     |  |   |  |                         |  |  |  |  |  |  |  |  |  |  |  |
|   |   |   |  |   |  |   |  |   |  |   |  |   |  |   |  |   |  |    |  |    |  |    |  |    |  |    |  |    |  |    |  | 1/4-18 NPT  |  | 7/16-20 UNF   |  | 1/2-14 NPT   |  | "T" Shape           |  | Standard  |  |                         |  |  |  |  |  |  |  |  |  |  |  |
|   |   |   |  |   |  |   |  |   |  |   |  |   |  |   |  |   |  |    |  |    |  |    |  |    |  |    |  |    |  |    |  | (*1)  |  | M10   |  | M20x1.5  |  |                     |  |   |  |                         |  |  |  |  |  |  |  |  |  |  |  |
|   |   |   |  |   |  |   |  |   |  |   |  |   |  |   |  |   |  |    |  |    |  |    |  |    |  |    |  |    |  |    |  |   |  |   |  | Pg13.5   |  |                     |  |   |  |                         |  |  |  |  |  |  |  |  |  |  |  |
|   |   |   |  |   |  |   |  |   |  |   |  |   |  |   |  |   |  |    |  |    |  |    |  |    |  |    |  |    |  |    |  | 1/4-18 NPT  |  | 7/16-20 UNF   |  | 1/2-14 NPT   |  | "T" Shape           |  | Bottom (Isoplanar)                                    |  |                         |  |  |  |  |  |  |  |  |  |  |  |
|   |   |   |  |   |  |   |  |   |  |   |  |   |  |   |  |   |  |    |  |    |  |    |  |    |  |    |  |    |  |    |  | (*1)  |  | M10   |  | M20x1.5  |  |                     |  |   |  |                         |  |  |  |  |  |  |  |  |  |  |  |
|   |   |   |  |   |  |   |  |   |  |   |  |   |  |   |  |   |  |    |  |    |  |    |  |    |  |    |  |    |  |    |  |   |  |   |  | Pg13.5   |  |                     |  |   |  |                         |  |  |  |  |  |  |  |  |  |  |  |
|   |   |   |  |   |  |   |  |   |  |   |  |   |  |   |  |   |  |    |  |    |  |    |  |    |  |    |  |    |  |    |  | (*2)(*3)  |  | Range and materials   |  | Process cover  |  | Diaphragm           |  | Wetted cell body                                      |  |                         |  |  |  |  |  |  |  |  |  |  |  |
|   |   |   |  |   |  |   |  |   |  |   |  |   |  |   |  |   |  |    |  |    |  |    |  |    |  |    |  |    |  |    |  | Static pressure limits                                |  | Measuring ranges  |  | LP side HP side  |  |                     |  |   |  |                         |  |  |  |  |  |  |  |  |  |  |  |
|   |   |   |  |   |  |   |  |   |  |   |  |   |  |   |  |   |  |    |  |    |  |    |  |    |  |    |  |    |  |    |  | -1 to 32 bar<br>-0.1 to 3.2 MPA<br>-14.5 to 464 psig  |  | 10/100 mm WC<br>0.1 to 1 kPa<br>0...1 to 10 mbar<br>0...10 to 100 mm WC             |  | SS 316L  |  | SS 316L             |  | SS 316L<br>Hastelloy C<br>Gold coating<br>Hastelloy C |  | SS 318LN<br>Hastelloy C |  |  |  |  |  |  |  |  |  |  |  |
|   |   |   |  |   |  |   |  |   |  |   |  |   |  |   |  |   |  |    |  |    |  |    |  |    |  |    |  |    |  |    |  | -1 to 100 bar<br>-0.1 to 10 MPA<br>-14.5 to 1450 psig |  | 10/600 mmWC<br>0.1 to 6 kPa<br>0...1 to 60 mbar<br>0...10 to 600 mm WC              |  | SS 316L  |  | SS 316L             |  | SS 316L<br>Hastelloy C<br>Gold coating<br>Hastelloy C |  | SS 318LN<br>Hastelloy C |  |  |  |  |  |  |  |  |  |  |  |
|   |   |   |  |   |  |   |  |   |  |   |  |   |  |   |  |   |  |    |  |    |  |    |  |    |  |    |  |    |  |    |  | (*4)  |  | 30/3200 mm WC<br>0.32 to 32 kPa<br>0...3.2 to 320 mbar<br>0...32 to 3200 mm WC      |  | SS 316L  |  | SS 316L             |  | SS 316L   |  | SS 316L                 |  |  |  |  |  |  |  |  |  |  |  |
|   |   |   |  |   |  |   |  |   |  |   |  |   |  |   |  |   |  |    |  |    |  |    |  |    |  |    |  |    |  |    |  |   |  |   |  |  |  |                     |  | Hastelloy C   |  | Hastelloy C             |  |  |  |  |  |  |  |  |  |  |  |
|   |   |   |  |   |  |   |  |   |  |   |  |   |  |   |  |   |  |    |  |    |  |    |  |    |  |    |  |    |  |    |  |   |  |   |  |  |  |                     |  | Monel   |  | Monel lining            |  |  |  |  |  |  |  |  |  |  |  |
|   |   |   |  |   |  |   |  |   |  |   |  |   |  |   |  |   |  |    |  |    |  |    |  |    |  |    |  |    |  |    |  |   |  |   |  |  |  |                     |  | Gold coating  |  | SS 316L                 |  |  |  |  |  |  |  |  |  |  |  |
|   |   |   |  |   |  |   |  |   |  |   |  |   |  |   |  |   |  |    |  |    |  |    |  |    |  |    |  |    |  |    |  |   |  |   |  |  |  |                     |  | Gold/ceramics   |  | Gold/ceramics           |  |  |  |  |  |  |  |  |  |  |  |
|   |   |   |  |   |  |   |  |   |  |   |  |   |  |   |  |   |  |    |  |    |  |    |  |    |  |    |  |    |  |    |  |   |  |   |  |  |  |                     |  | Tantalum  |  | Tantalum lining         |  |  |  |  |  |  |  |  |  |  |  |
|   |   |   |  |   |  |   |  |   |  |   |  |   |  |   |  |   |  |    |  |    |  |    |  |    |  |    |  |    |  |    |  | (*4)  |  | -1 to 160 bar<br>-0.1 to 16 MPA<br>-14.5 to 2320 psig<br>(*3)                       |  | 0.13/13 m WC<br>1.3 to 130 kPa<br>0...13 to 1300 mbar<br>0...0.13 to 13 m WC |  | SS 316L             |  | SS 316L   |  | SS 316L                 |  |  |  |  |  |  |  |  |  |  |  |
|   |   |   |  |   |  |   |  |   |  |   |  |   |  |   |  |   |  |    |  |    |  |    |  |    |  |    |  |    |  |    |  |   |  |   |  |  |  |                     |  | Hastelloy C   |  | Hastelloy C             |  |  |  |  |  |  |  |  |  |  |  |
|   |   |   |  |   |  |   |  |   |  |   |  |   |  |   |  |   |  |    |  |    |  |    |  |    |  |    |  |    |  |    |  |   |  |   |  |  |  |                     |  | Monel   |  | Monel lining            |  |  |  |  |  |  |  |  |  |  |  |
|   |   |   |  |   |  |   |  |   |  |   |  |   |  |   |  |   |  |    |  |    |  |    |  |    |  |    |  |    |  |    |  |   |  |   |  |  |  |                     |  | Gold coating  |  | SS 316L                 |  |  |  |  |  |  |  |  |  |  |  |
|   |   |   |  |   |  |   |  |   |  |   |  |   |  |   |  |   |  |    |  |    |  |    |  |    |  |    |  |    |  |    |  |   |  |   |  |  |  |                     |  | Gold/ceramics   |  | Gold/ceramics           |  |  |  |  |  |  |  |  |  |  |  |
|   |   |   |  |   |  |   |  |   |  |   |  |   |  |   |  |   |  |    |  |    |  |    |  |    |  |    |  |    |  |    |  |   |  |   |  |  |  |                     |  | Tantalum  |  | Tantalum lining         |  |  |  |  |  |  |  |  |  |  |  |
|   |   |   |  |   |  |   |  |   |  |   |  |   |  |   |  |   |  |    |  |    |  |    |  |    |  |    |  |    |  |    |  | (*4)  |  | 0.5/50 m WC<br>5 to 500 kPa<br>0...50 to 5000 mbar<br>0...0.5 to 50 m WC            |  | SS 316L  |  | SS 316L             |  | SS 316L   |  |                         |  |  |  |  |  |  |  |  |  |  |  |
|   |   |   |  |   |  |   |  |   |  |   |  |   |  |   |  |   |  |    |  |    |  |    |  |    |  |    |  |    |  |    |  |   |  |   |  |  |  | Hastelloy C         |  | Hastelloy C   |  |                         |  |  |  |  |  |  |  |  |  |  |  |
|   |   |   |  |   |  |   |  |   |  |   |  |   |  |   |  |   |  |    |  |    |  |    |  |    |  |    |  |    |  |    |  |   |  |   |  |  |  | Gold coating        |  | SS 316L   |  |                         |  |  |  |  |  |  |  |  |  |  |  |
|   |   |   |  |   |  |   |  |   |  |   |  |   |  |   |  |   |  |    |  |    |  |    |  |    |  |    |  |    |  |    |  |   |  |   |  |  |  | Monel               |  | Monel lining  |  |                         |  |  |  |  |  |  |  |  |  |  |  |
|   |   |   |  |   |  |   |  |   |  |   |  |   |  |   |  |   |  |    |  |    |  |    |  |    |  |    |  |    |  |    |  |   |  |   |  |  |  | Tantalum            |  | Tantalum lining                                       |  |                         |  |  |  |  |  |  |  |  |  |  |  |
|   |   |   |  |   |  |   |  |   |  |   |  |   |  |   |  |   |  |    |  |    |  |    |  |    |  |    |  |    |  |    |  |   |  |   |  |  |  | SS 316L             |  | SS 316L   |  |                         |  |  |  |  |  |  |  |  |  |  |  |
|   |   |   |  |   |  |   |  |   |  |   |  |   |  |   |  |   |  |    |  |    |  |    |  |    |  |    |  |    |  |    |  | (*4)  |  | 3/300 m WC<br>30 to 3000 kPa<br>0...0.3 to 30 bar<br>0...3 to 300 m WC              |  | SS 316L  |  | SS 316L             |  | SS 316L   |  |                         |  |  |  |  |  |  |  |  |  |  |  |
|   |   |   |  |   |  |   |  |   |  |   |  |   |  |   |  |   |  |    |  |    |  |    |  |    |  |    |  |    |  |    |  |   |  |   |  |  |  | Hastelloy C         |  | Hastelloy C   |  |                         |  |  |  |  |  |  |  |  |  |  |  |
|   |   |   |  |   |  |   |  |   |  |   |  |   |  |   |  |   |  |    |  |    |  |    |  |    |  |    |  |    |  |    |  |   |  |   |  |  |  | Gold coating        |  | SS 316L   |  |                         |  |  |  |  |  |  |  |  |  |  |  |
|   |   |   |  |   |  |   |  |   |  |   |  |   |  |   |  |   |  |    |  |    |  |    |  |    |  |    |  |    |  |    |  |   |  |   |  |  |  | SS 316L             |  | SS 316L   |  |                         |  |  |  |  |  |  |  |  |  |  |  |
|   |   |   |  |   |  |   |  |   |  |   |  |   |  |   |  |   |  |    |  |    |  |    |  |    |  |    |  |    |  |    |  |   |  |   |  |  |  | Hastelloy C         |  | Hastelloy C   |  |                         |  |  |  |  |  |  |  |  |  |  |  |
|   |   |   |  |   |  |   |  |   |  |   |  |   |  |   |  |   |  |    |  |    |  |    |  |    |  |    |  |    |  |    |  |   |  |   |  |  |  | Monel               |  | Monel lining  |  |                         |  |  |  |  |  |  |  |  |  |  |  |
|   |   |   |  |   |  |   |  |   |  |   |  |   |  |   |  |   |  |    |  |    |  |    |  |    |  |    |  |    |  |    |  | (*4)  |  | -1 to 420 bar<br>-0.1 to 42 MPA<br>-14.5 to 6091 psig<br>(*3)                       |  | SS 316L  |  | SS 316L             |  | SS 316L   |  |                         |  |  |  |  |  |  |  |  |  |  |  |
|   |   |   |  |   |  |   |  |   |  |   |  |   |  |   |  |   |  |    |  |    |  |    |  |    |  |    |  |    |  |    |  |   |  |   |  |  |  | Hastelloy C         |  | Hastelloy C   |  |                         |  |  |  |  |  |  |  |  |  |  |  |
|   |   |   |  |   |  |   |  |   |  |   |  |   |  |   |  |   |  |    |  |    |  |    |  |    |  |    |  |    |  |    |  |   |  |   |  |  |  | Monel               |  | Monel lining  |  |                         |  |  |  |  |  |  |  |  |  |  |  |
|   |   |   |  |   |  |   |  |   |  |   |  |   |  |   |  |   |  |    |  |    |  |    |  |    |  |    |  |    |  |    |  |   |  |   |  |  |  | Gold coating        |  | SS 316L   |  |                         |  |  |  |  |  |  |  |  |  |  |  |
|   |   |   |  |   |  |   |  |   |  |   |  |   |  |   |  |   |  |    |  |    |  |    |  |    |  |    |  |    |  |    |  |   |  |   |  |  |  | SS 316L             |  | SS 316L   |  |                         |  |  |  |  |  |  |  |  |  |  |  |
|   |   |   |  |   |  |   |  |   |  |   |  |   |  |   |  |   |  |    |  |    |  |    |  |    |  |    |  |    |  |    |  |   |  |   |  |  |  | Hastelloy C         |  | Hastelloy C   |  |                         |  |  |  |  |  |  |  |  |  |  |  |
|   |   |   |  |   |  |   |  |   |  |   |  |   |  |   |  |   |  |    |  |    |  |    |  |    |  |    |  |    |  |    |  | (*4)  |  | 0.5/50 m WC<br>5 to 500 kPa<br>0...50 to 5000 mbar<br>0...0.5 to 50 m WC            |  | SS 316L  |  | SS 316L             |  | SS 316L   |  |                         |  |  |  |  |  |  |  |  |  |  |  |
|   |   |   |  |   |  |   |  |   |  |   |  |   |  |   |  |   |  |    |  |    |  |    |  |    |  |    |  |    |  |    |  |   |  |   |  |  |  | Hastelloy C         |  | Hastelloy C   |  |                         |  |  |  |  |  |  |  |  |  |  |  |
|   |   |   |  |   |  |   |  |   |  |   |  |   |  |   |  |   |  |    |  |    |  |    |  |    |  |    |  |    |  |    |  |   |  |   |  |  |  | Monel               |  | Monel lining  |  |                         |  |  |  |  |  |  |  |  |  |  |  |
|   |   |   |  |   |  |   |  |   |  |   |  |   |  |   |  |   |  |    |  |    |  |    |  |    |  |    |  |    |  |    |  |   |  |   |  |  |  | Gold coating        |  | SS 316L   |  |                         |  |  |  |  |  |  |  |  |  |  |  |
|   |   |   |  |   |  |   |  |   |  |   |  |   |  |   |  |   |  |    |  |    |  |    |  |    |  |    |  |    |  |    |  |   |  |   |  |  |  | SS 316L             |  | SS 316L   |  |                         |  |  |  |  |  |  |  |  |  |  |  |
|   |   |   |  |   |  |   |  |   |  |   |  |   |  |   |  |   |  |    |  |    |  |    |  |    |  |    |  |    |  |    |  |   |  |   |  |  |  | Hastelloy C         |  | Hastelloy C   |  |                         |  |  |  |  |  |  |  |  |  |  |  |
|   |   |   |  |   |  |   |  |   |  |   |  |   |  |   |  |   |  |    |  |    |  |    |  |    |  |    |  |    |  |    |  | (*4)  |  | -1 to 300 bar<br>-0.1 to 30 MPA<br>-14.5 to 4351 psig                               |  | SS 316L  |  | SS 316L             |  | SS 316L   |  |                         |  |  |  |  |  |  |  |  |  |  |  |
|   |   |   |  |   |  |   |  |   |  |   |  |   |  |   |  |   |  |    |  |    |  |    |  |    |  |    |  |    |  |    |  |   |  |   |  |  |  | Hastelloy C         |  | Hastelloy C   |  |                         |  |  |  |  |  |  |  |  |  |  |  |
|   |   |   |  |   |  |   |  |   |  |   |  |   |  |   |  |   |  |    |  |    |  |    |  |    |  |    |  |    |  |    |  |   |  |   |  |  |  | Gold coating        |  | SS 316L   |  |                         |  |  |  |  |  |  |  |  |  |  |  |
|   |   |   |  |   |  |   |  |   |  |   |  |   |  |   |  |   |  |    |  |    |  |    |  |    |  |    |  |    |  |    |  |   |  |   |  |  |  | SS 316L             |  | SS 316L   |  |                         |  |  |  |  |  |  |  |  |  |  |  |
|   |   |   |  |   |  |   |  |   |  |   |  |   |  |   |  |   |  |    |  |    |  |    |  |    |  |    |  |    |  |    |  |   |  |   |  |  |  | Hastelloy C         |  | Hastelloy C   |  |                         |  |  |  |  |  |  |  |  |  |  |  |
|   |   |   |  |   |  |   |  |   |  |   |  |   |  |   |  |   |  |    |  |    |  |    |  |    |  |    |  |    |  |    |  |   |  |   |  |  |  | Gold coating        |  | SS 316L   |  |                         |  |  |  |  |  |  |  |  |  |  |  |
|   |   |   |  |   |  |   |  |   |  |   |  |   |  |   |  |   |  |    |  |    |  |    |  |    |  |    |  |    |  |    |  | (*4)  |  | 50/2000 m WC<br>500 to 20000 kPa  |  | SS 316L  |  | SS 316L             |  | SS 316L   |  |                         |  |  |  |  |  |  |  |  |  |  |  |
|   |   |   |  |   |  |   |  |   |  |   |  |   |  |   |  |   |  |    |  |    |  |    |  |    |  |    |  |    |  |    |  |   |  |   |  |  |  | Gold coating        |  | SS 316L   |  |                         |  |  |  |  |  |  |  |  |  |  |  |

| 1 | 2 | 3 | 4 | 5 | 6 | 7 | 8 | 9 | 10 | 11 | 12 | 13 | 14 | 15 | 16 | DESCRIPTION   |   |             |             |             |             |  |
|---|---|---|---|---|---|---|---|---|----|----|----|----|----|----|----|---|---|-------------|-------------|-------------|-------------|--|
| F | K | C |   |   |   |   |   |   |    |    |    |    |    |    |    |   |   |             |             |             |             |  |
|   | 8 | 1 | H |   |   |   |   |   |    |    |    |    |    |    |    | 0 to 15 bar<br>0 to 1.5 MPa<br>0 to 217 psig  | 10/100 mm WC<br>0.1 to 1 kPa<br>0...1 to 10 mbar<br>0...10 to 100 mm WC | PVDF insert | Hastelloy C | Hastelloy C |             |  |
|   | 8 | 2 | H |   |   |   |   |   |    |    |    |    |    |    |    |   | 10/600 mm WC<br>0.1 to 6 kPa<br>0...1 to 60 mbar<br>0...10 to 600 mm WC |             |             |             |             |  |
|   | 8 | 3 | H |   |   |   |   |   |    |    |    |    |    |    |    |   | 32/3200 mm WC<br>0.32 to 32 kPa<br>0...3.2 to 320 mbar                  |             |             |             |             |  |
|   | 8 | 3 | M |   |   |   |   |   |    |    |    |    |    |    |    |   | 0.13/13 m WC<br>1.3 to 130 kPa<br>0...13 to 1300 mbar                   |             |             |             |             |  |
|   | 8 | 3 | T |   |   |   |   |   |    |    |    |    |    |    |    |   | 0.5/50 m WC<br>5 to 500 kPa<br>0...50 to 5000 mbar                      |             |             |             |             |  |
|   | 8 | 5 | H |   |   |   |   |   |    |    |    |    |    |    |    |   | 10/100 mm WC<br>0.1 to 1 kPa<br>0...1 to 10 mbar<br>0...10 to 100 mm WC |             |             |             |             |  |
|   | 8 | 5 | M |   |   |   |   |   |    |    |    |    |    |    |    |   | 10/600 mm WC<br>0.1 to 6 kPa<br>0...1 to 60 mbar<br>0...10 to 600 mm WC |             |             |             |             |  |
|   | 8 | 5 | T |   |   |   |   |   |    |    |    |    |    |    |    |   | 32/3200 mm WC<br>0.32 to 32 kPa<br>0...3.2 to 320 mbar                  |             |             |             |             |  |
|   | 8 | 6 | H |   |   |   |   |   |    |    |    |    |    |    |    | 0.13/13 m WC<br>1.3 to 130 kPa<br>0...13 to 1300 mbar                                 |   |             |             |             |             |  |
|   | 8 | 6 | M |   |   |   |   |   |    |    |    |    |    |    |    | 0.5/50 m WC<br>5 to 500 kPa<br>0...50 to 5000 mbar                                    |   |             |             |             |             |  |
|   | 8 | 6 | T |   |   |   |   |   |    |    |    |    |    |    |    | 10/100 mm WC<br>0.1 to 1 kPa<br>0...1 to 10 mbar<br>0...10 to 100 mm WC               |   |             |             |             |             |  |
|   | 9 | 1 | H |   |   |   |   |   |    |    |    |    |    |    |    | 0 to 15 bar<br>0 to 1.5 MPa<br>0 to 217 psig  | 10/100 mm WC<br>0.1 to 1 kPa<br>0...1 to 10 mbar<br>0...10 to 100 mm WC | PVDF insert | SS 316L     | Hastelloy C | Hastelloy C |  |
|   | 9 | 2 | H |   |   |   |   |   |    |    |    |    |    |    |    |   | 10/600 mm WC<br>0.1 to 6 kPa<br>0...1 to 60 mbar<br>0...10 to 600 mm WC |             |             |             |             |  |
|   | 9 | 3 | H |   |   |   |   |   |    |    |    |    |    |    |    |   | 32/3200 mm WC<br>0.32 to 32 kPa<br>0...3.2 to 320 mbar                  |             |             |             |             |  |
|   | 9 | 3 | M |   |   |   |   |   |    |    |    |    |    |    |    |   | 0.13/13 m WC<br>1.3 to 130 kPa<br>0...13 to 1300 mbar                   |             |             |             |             |  |
|   | 9 | 3 | T |   |   |   |   |   |    |    |    |    |    |    |    |   | 0.5/50 m WC<br>5 to 500 kPa<br>0...50 to 5000 mbar                      |             |             |             |             |  |
|   | 9 | 5 | H |   |   |   |   |   |    |    |    |    |    |    |    |   | 10/100 mm WC<br>0.1 to 1 kPa<br>0...1 to 10 mbar<br>0...10 to 100 mm WC |             |             |             |             |  |
|   | 9 | 5 | M |   |   |   |   |   |    |    |    |    |    |    |    |   | 10/600 mm WC<br>0.1 to 6 kPa<br>0...1 to 60 mbar<br>0...10 to 600 mm WC |             |             |             |             |  |
|   | 9 | 5 | T |   |   |   |   |   |    |    |    |    |    |    |    |   | 32/3200 mm WC<br>0.32 to 32 kPa<br>0...3.2 to 320 mbar                  |             |             |             |             |  |
|   | 9 | 6 | H |   |   |   |   |   |    |    |    |    |    |    |    | 0.13/13 m WC<br>1.3 to 130 kPa<br>0...13 to 1300 mbar                                 |   |             |             |             |             |  |
|   | 9 | 6 | M |   |   |   |   |   |    |    |    |    |    |    |    | 0.5/50 m WC<br>5 to 500 kPa<br>0...50 to 5000 mbar                                    |   |             |             |             |             |  |
|   | 9 | 6 | T |   |   |   |   |   |    |    |    |    |    |    |    | 10/100 mm WC<br>0.1 to 1 kPa<br>0...1 to 10 mbar<br>0...10 to 100 mm WC               |   |             |             |             |             |  |
|   | 6 |   |   |   |   |   |   |   |    |    |    |    |    |    |    | <b>Improvement Symbol</b>   |   |             |             |             |             |  |
|   | A |   |   |   |   |   |   |   |    |    |    |    |    |    |    | <b>Indicator</b>  | <b>Arrester</b>   |             |             |             |             |  |
|   | E |   |   |   |   |   |   |   |    |    |    |    |    |    |    | None  | None  |             |             |             |             |  |
|   | L |   |   |   |   |   |   |   |    |    |    |    |    |    |    | None  | Yes   |             |             |             |             |  |
|   | P |   |   |   |   |   |   |   |    |    |    |    |    |    |    | Digital, 0-100% linear scale  |   |             |             |             |             |  |
|   | M |   |   |   |   |   |   |   |    |    |    |    |    |    |    | Digital, custom scale   | None  |             |             |             |             |  |
|   | Q |   |   |   |   |   |   |   |    |    |    |    |    |    |    | Digital, 0-100% √ scale   |   |             |             |             |             |  |
|   | S |   |   |   |   |   |   |   |    |    |    |    |    |    |    | Digital, 0-100% linear scale  |   |             |             |             |             |  |
|   | N |   |   |   |   |   |   |   |    |    |    |    |    |    |    | Digital, custom scale   | Yes   |             |             |             |             |  |
|   | 1 |   |   |   |   |   |   |   |    |    |    |    |    |    |    | Digital, 0-100% √ scale   |   |             |             |             |             |  |
|   | 2 |   |   |   |   |   |   |   |    |    |    |    |    |    |    | Digital, 0-100% linear scale (Local configurator)                                     |   |             |             |             |             |  |
|   | 3 |   |   |   |   |   |   |   |    |    |    |    |    |    |    | Digital, custom scale (Local configurator)  | None  |             |             |             |             |  |
|   | 4 |   |   |   |   |   |   |   |    |    |    |    |    |    |    | Digital, 0-100% √ scale (Local configurator)  |   |             |             |             |             |  |
|   | 5 |   |   |   |   |   |   |   |    |    |    |    |    |    |    | Digital, 0-100% linear scale (Local configurator)                                     |   |             |             |             |             |  |
|   | 6 |   |   |   |   |   |   |   |    |    |    |    |    |    |    | Digital, custom scale (Local configurator)  | Yes   |             |             |             |             |  |
|   |   |   |   |   |   |   |   |   |    |    |    |    |    |    |    | Digital, 0-100% √ scale (Local configurator)  |   |             |             |             |             |  |
|   | A |   |   |   |   |   |   |   |    |    |    |    |    |    |    | <b>Hazardous location approvals</b>   |   |             |             |             |             |  |
|   | X |   |   |   |   |   |   |   |    |    |    |    |    |    |    | None  |   |             |             |             |             |  |
|   | K |   |   |   |   |   |   |   |    |    |    |    |    |    |    | (*5) ATEX - Flameproof  |   |             |             |             |             |  |
|   | M |   |   |   |   |   |   |   |    |    |    |    |    |    |    | ATEX - Intrinsic Safety   |   |             |             |             |             |  |
|   | E |   |   |   |   |   |   |   |    |    |    |    |    |    |    | (*5) ATEX - Combination Flameproof and Intrinsic Safety                               | pending   |             |             |             |             |  |
|   | J |   |   |   |   |   |   |   |    |    |    |    |    |    |    | (*5) cCSAus - Explosion proof   | pending   |             |             |             |             |  |
|   | L |   |   |   |   |   |   |   |    |    |    |    |    |    |    | cCSAus - Intrinsic Safety and Non Incendive   | pending   |             |             |             |             |  |
|   | R |   |   |   |   |   |   |   |    |    |    |    |    |    |    | (*5) cCSAus - Combination Explosion proof, Intrinsic Safety and Non Incendive         | pending   |             |             |             |             |  |
|   | T |   |   |   |   |   |   |   |    |    |    |    |    |    |    | (*5) IECEx - Flameproof   |   |             |             |             |             |  |
|   | N |   |   |   |   |   |   |   |    |    |    |    |    |    |    | IECEx - Intrinsic Safety  |   |             |             |             |             |  |
|   | W |   |   |   |   |   |   |   |    |    |    |    |    |    |    | (*5) IECEx - Combination Flameproof and Intrinsic Safety                              | pending   |             |             |             |             |  |
|   |   |   |   |   |   |   |   |   |    |    |    |    |    |    |    | (*5) IECEx - ATEX - cCSAus - Explosion/Flameproof, Intrinsic Safety and Non Incendive | pending   |             |             |             |             |  |
|   | A |   |   |   |   |   |   |   |    |    |    |    |    |    |    | (*1,*6) <b>Side vent/drain</b>  | <b>Mounting bracket</b>   |             |             |             |             |  |
|   | K |   |   |   |   |   |   |   |    |    |    |    |    |    |    | None (standard)   | None  |             |             |             |             |  |
|   | D |   |   |   |   |   |   |   |    |    |    |    |    |    |    | Yes   | SS 316L   |             |             |             |             |  |
|   | L |   |   |   |   |   |   |   |    |    |    |    |    |    |    |   | None  |             |             |             |             |  |
|   |   |   |   |   |   |   |   |   |    |    |    |    |    |    |    |   | SS 316L   |             |             |             |             |  |
|   | Y |   |   |   |   |   |   |   |    |    |    |    |    |    |    | <b>Stainless steel parts</b>  |   |             |             |             |             |  |
|   | B |   |   |   |   |   |   |   |    |    |    |    |    |    |    | <b>TAG plate</b>  | <b>Housing</b>  |             |             |             |             |  |
|   | C |   |   |   |   |   |   |   |    |    |    |    |    |    |    | None  | None  |             |             |             |             |  |
|   | E |   |   |   |   |   |   |   |    |    |    |    |    |    |    | Yes   |   |             |             |             |             |  |
|   |   |   |   |   |   |   |   |   |    |    |    |    |    |    |    | None  |   |             |             |             |             |  |
|   |   |   |   |   |   |   |   |   |    |    |    |    |    |    |    | Yes   | Yes   |             |             |             |             |  |

| 1  | 2 | 3 | 4 | 5 | 6 | 7 | 8 | 9 | 10 | 11 | 12 | 13 | 14 | 15 | 16 | DESCRIPTION |  |
|--|---|---|---|---|---|---|---|---|----|----|----|----|----|----|----|-------------|--|
| F  | K | C |   |   |   |   |   |   |    |    |    |    |    |    |    |             |  |
| <b>Special applications &amp; Filling fluids</b>                   |   |   |   |   |   |   |   |   |    |    |    |    |    |    |    |             |  |
| <b>Treatment</b> <b>Filling fluid</b>                              |   |   |   |   |   |   |   |   |    |    |    |    |    |    |    |             |  |
| Y  |   |   |   |   |   |   |   |   |    |    |    |    |    |    |    |             |  |
| W  |   |   |   |   |   |   |   |   |    |    |    |    |    |    |    |             |  |
| G  |   |   |   |   |   |   |   |   |    |    |    |    |    |    |    |             |  |
| A  |   |   |   |   |   |   |   |   |    |    |    |    |    |    |    |             |  |
| D  |   |   |   |   |   |   |   |   |    |    |    |    |    |    |    |             |  |
| N  |   |   |   |   |   |   |   |   |    |    |    |    |    |    |    |             |  |
| <b>Process cover gasket</b> <b>Vent Drain plug</b> <b>Bolt/Nut</b> |   |   |   |   |   |   |   |   |    |    |    |    |    |    |    |             |  |
| C  |   |   |   |   |   |   |   |   |    |    |    |    |    |    |    |             |  |
| H  |   |   |   |   |   |   |   |   |    |    |    |    |    |    |    |             |  |
| G  |   |   |   |   |   |   |   |   |    |    |    |    |    |    |    |             |  |
| J  |   |   |   |   |   |   |   |   |    |    |    |    |    |    |    |             |  |
| K  |   |   |   |   |   |   |   |   |    |    |    |    |    |    |    |             |  |
| D  |   |   |   |   |   |   |   |   |    |    |    |    |    |    |    |             |  |
| E  |   |   |   |   |   |   |   |   |    |    |    |    |    |    |    |             |  |
| F  |   |   |   |   |   |   |   |   |    |    |    |    |    |    |    |             |  |
| 4  |   |   |   |   |   |   |   |   |    |    |    |    |    |    |    |             |  |
| 6  |   |   |   |   |   |   |   |   |    |    |    |    |    |    |    |             |  |
| 5  |   |   |   |   |   |   |   |   |    |    |    |    |    |    |    |             |  |
| 7  |   |   |   |   |   |   |   |   |    |    |    |    |    |    |    |             |  |
| 8  |   |   |   |   |   |   |   |   |    |    |    |    |    |    |    |             |  |
| <b>Special options</b>   |   |   |   |   |   |   |   |   |    |    |    |    |    |    |    |             |  |
| L  |   |   |   |   |   |   |   |   |    |    |    |    |    |    |    |             |  |
| T  |   |   |   |   |   |   |   |   |    |    |    |    |    |    |    |             |  |
| Instruction manual unattached                                      |   |   |   |   |   |   |   |   |    |    |    |    |    |    |    |             |  |
| (*8) * special, no code available                                  |   |   |   |   |   |   |   |   |    |    |    |    |    |    |    |             |  |

## Notes\*:

- 1- Isoplanar process connection (bottom side) with side vent/drain only. 160 bar MWP with M10 process cover bolting.
- 2- Select M12 bolting if static pressure > 160 bar.
- 3- A Turn Down Ratio ≤ 10 is recommended for optimal performances.
- 4- Gold/ceramic coating available upon request.
- 5- Only with M20x1.5 & 1/2"-14 NPT electrical conduits.
- 6- Process cover with PVDF insert: 1/2"-14 NPT side process connection only, square section PTFE gasket, no vent/drain.
- 7- SS 660 bolts/nuts are in conformity with NACE MR0175/ISO 15156 and must be used for NACE service.
- 8- When no code can be found in the current model code, place "\*" in the corresponding digit code as well as in the 16th digit.



# OUTLINE DIAGRAM (Unit : mm)

<L SHAPE> <4TH DIGIT CODE: R, T, U, V, W, X AND 7TH DIGIT CODE V, H, M, T>

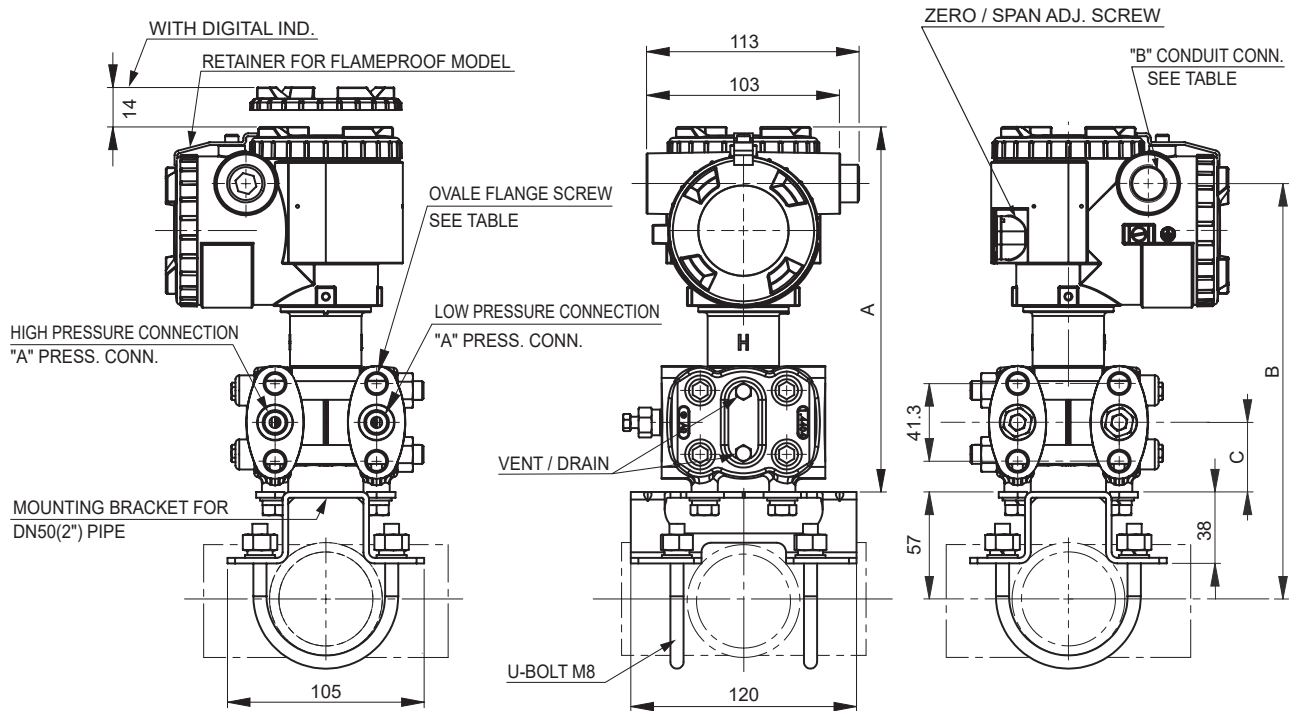

DETAIL "B" (CONDUIT CONN.)

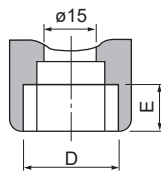

SEE TABLE

DETAIL "A" (PRESS. CONN.)

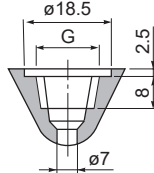

SEE TABLE

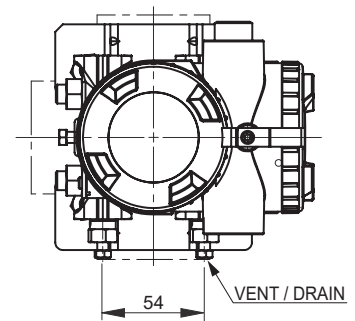

| 4TH MODEL CODE | CONDUIT CONNECTION |      | PRESS. CONN. | OVAL FLANGE SCREW |
|----------------|--------------------|------|--------------|-------------------|
|                | D                  | E    | G            |                   |
| R              | M20×1.5            | 16   | 1/4-18NPT    | 7/16-20UNF        |
| T              | 1/2-14NPT          | 16   | 1/4-18NPT    | 7/16-20UNF        |
| U              | 1/2-14NPT          | 16   | 1/4-18NPT    | M10 or M12        |
| V              | Pg13.5             | 10.5 | 1/4-18NPT    | M10 or M12        |
| W              | M20×1.5            | 16   | 1/4-18NPT    | M10 or M12        |
| X              | Pg13.5             | 10.5 | 1/4-18NPT    | 7/16-20 UNF       |

TABLE

| MODEL  | DIMENSIONS |       |        |
|--------|------------|-------|--------|
|        | A          | B     | C      |
| FKC□11 | 198.5      | 225.5 | 38.5   |
| FKC□22 |            |       |        |
| FKC□33 | 194        | 221   | 37     |
| FKC□35 | (198)      | (225) | (38.5) |
| FKC□36 | NOTE       | NOTE  | NOTE   |
| FKC□38 |            |       |        |
| FKC□43 |            |       |        |
| FKC□45 | 198.5      | 225.5 | 38.5   |
| FKC□46 |            |       |        |
| FKC□48 |            |       |        |

NOTE: 7TH MODEL CODE "M", "T"

- WEIGHT : - 3.5 kg (WITHOUT OPTION)  
 ADD : - 0.2 kg FOR INDICATOR  
 - 0.5 kg FOR MOUNTING BRACKET  
 - 2.0 kg FOR STAINLESS STEEL HOUSING OPTION

# OUTLINE DIAGRAM (Unit : mm)

<T SHAPE> <4TH DIGIT CODE: 3, 4, 6, 7, 8, 9 AND 7TH DIGIT CODE V, H, M, T>

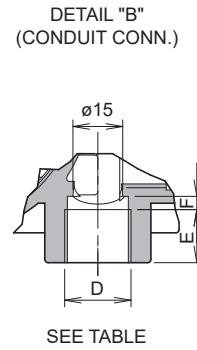
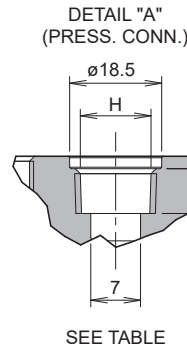
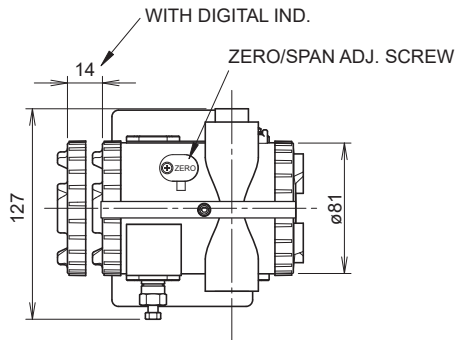
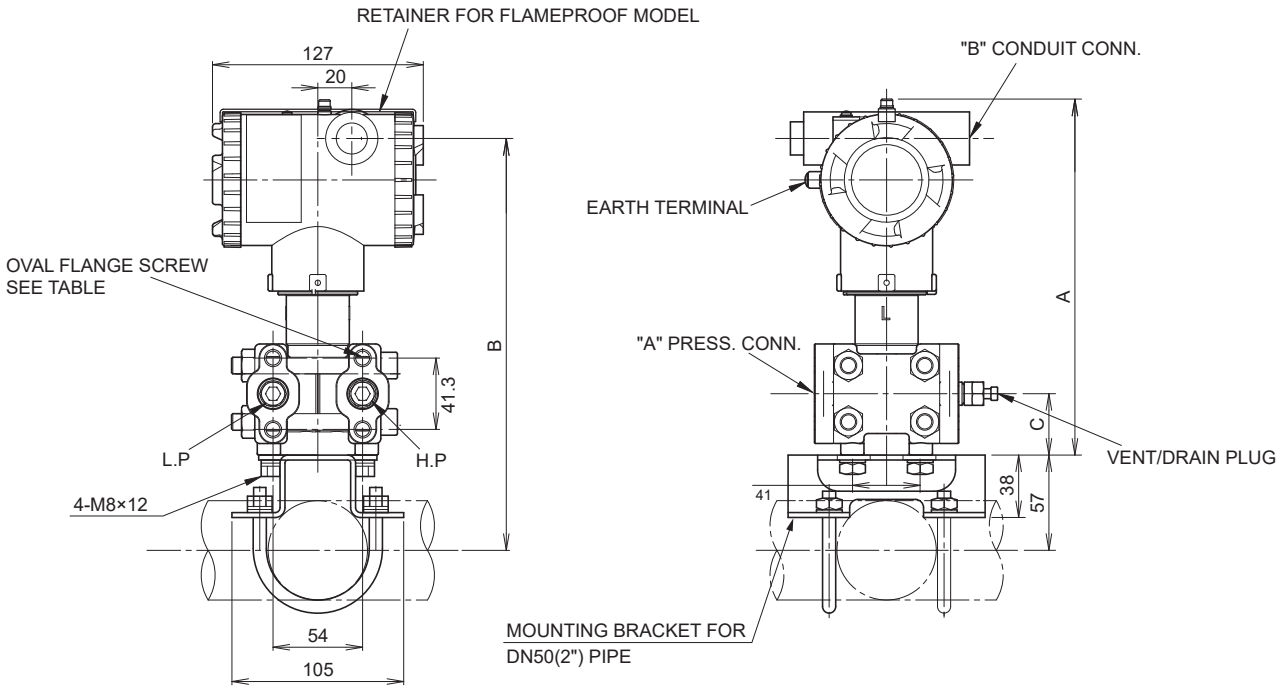

| 4TH MODEL CODE | CONDUIT CONNECTION |      |     | PRESS. CONN. | OVAL FLANGE SCREW |
|----------------|--------------------|------|-----|--------------|-------------------|
|                | D                  | E    | F   | H            |                   |
| 3              | M20x1.5            | 16   | 4   | Rc1/4        | 7/16-20UNF        |
| 4              | 1/2-14NPT          | 16   | 4   | 1/4-18NPT    | M10 or M12        |
| 6              | 1/2-14NPT          | 16   | 4   | 1/4-18NPT    | 7/16-20UNF        |
| 7              | Pg13.5             | 10.5 | 4.5 | 1/4-18NPT    | M10 or M12        |
| 8              | M20x1.5            | 16   | 4   | 1/4-18NPT    | M10 or M12        |
| 9              | Pg13.5             | 10.5 | 4.5 | 1/4-18NPT    | 7/16-20UNF        |

TABLE

| MODEL  | DIMENSIONS |       |        |
|--------|------------|-------|--------|
|        | A          | B     | C      |
| FKC□11 | 219        | 252   | 38.5   |
| FKC□22 |            |       |        |
| FKC□33 | 215        | 248   | 37     |
| FKC□35 | (219)      | (252) | (38.5) |
| FKC□36 | NOTE       | NOTE  | NOTE   |
| FKC□38 | 219        | 252   | 38.5   |
| FKC□43 |            |       |        |
| FKC□45 |            |       |        |
| FKC□46 |            |       |        |
| FKC□48 |            |       |        |

NOTE: 7TH MODEL CODE "M", "T"

- WEIGHT : - 3.5 kg (WITHOUT OPTION)
- ADD : - 0.2 kg FOR INDICATOR
- 0.5 kg FOR MOUNTING BRACKET
- 2.0 kg FOR STAINLESS STEEL HOUSING OPTION



---

**Fuji Electric France S.A.S.**

46 rue Georges Besse - ZI du brézet - 63039 Clermont ferrand

Tél : 04 73 98 26 98 - Fax : 04 73 98 26 99

Mail : [sales.dpt@fujielectric.fr](mailto:sales.dpt@fujielectric.fr) - web : [www.fujielectric.fr](http://www.fujielectric.fr)

---

Fuji Electric can accept no responsibility for possible errors in catalogues, brochures and other printed material. Fuji Electric reserves the right to alter its products without notice. This also applies to products already on order provided that such alterations can be made without subsequential changes being necessary in specifications already agreed. All trademarks in this material are property of the respective companies. All rights reserved.

---