



Instruction Manual

NDIR TYPE INFRARED GAS ANALYZER

TYPE: ZKJ-6



PREFACE

Thank you very much for purchasing Fuji's Infrared Gas Analyzer.

- Be sure to read this instruction manual carefully before performing installation, wiring, operation, and maintenance of the analyzer. Improper handling may result in accidents or injury.
- The specifications of this analyzer are subject to change without prior notice for further product improvement.
- Modification of this analyzer is strictly prohibited unless a written approval is obtained from the manufacturer. Fuji will not bear any responsibility for a trouble caused by such a modification.
- The person who actually operates the analyzer should keep this instruction manual.
- After reading through the manual, be sure to keep it near at hand for future reference.
- This instruction manual should be delivered to the end user without fail.
- If you return the product to us for repair, provide us with a document that indicates the purpose of export is repair, and a certificate that indicates that the equipment includes no substances restricted by RoHS directive or laws and regulations of the exporting country. We are not liable in the cases that the re-export from Japan to you is not permitted due to imperfection of the above documents.

Manufacturer : Fuji Electric Co., Ltd.
Type : Described in the nameplate on main frame
Date of manufacture : Described in the nameplate on main frame
Country of manufacture : Japan

Delivered Items

| Name | Quantity | Remarks |
|----------------------------------|----------|--------------------------|
| Analyzer | 1 unit | |
| Input/Output terminal module | 1 set | |
| I/O module connection cable | 1 pc | |
| Power cord | 1 pc | |
| Fuse | 2 pcs | 250V AC/3.15A |
| Cell window mounting tool | 1 pc | With mounting block cell |
| Slide rail | 2 pcs | When specified |
| Relay board for auto calibration | 1 pc | When specified |
| Relay board connection cable | 1 pc | When specified |
| Relay board housing | 8 pcs | When specified |
| Relay board contact | 16 pcs | When specified |
| Instruction manual | 1 copy | |

Request

- No part or the whole of this manual may be reproduced without written permission of Fuji.
- Description in this manual is subject to change without prior notice for further improvement.

© Fuji Electric Co., Ltd.





2018



Issued in February, 2018
1st edition June, 2018
2nd edition April, 2020
3rd edition June, 2022

CAUTION ON SAFETY

To operate the analyzer properly, be sure to read “Caution on Safety” carefully.



- The descriptions listed here provide important information on safety. Be sure to observe them at all times. Those safety precautions are classified into 3 levels, “DANGER,” “CAUTION” and “PROHIBITION.”

| | |
|--|--|
|  DANGER | Improper handling may cause dangerous situations that may result in death or serious injury. |
|  CAUTION | Improper handling may cause dangerous situations that may result in medium-level troubles, minor injury, or property damage. |
|  PROHIBITION | Items which must not be done are noted. |
|  CAUTION | Items which indicates the possibility of receiving electric shock if it is handled incorrectly. |

| Caution on installation and transport of gas analyzer | |
|--|---|
|  DANGER | <ul style="list-style-type: none"> • The unit is not of explosion-proof specifications. Do not use it in an atmosphere of explosive gases. Otherwise serious accidents such as explosion or fire may result. |
|  CAUTION | <ul style="list-style-type: none"> • Install the analyzer, observing the rules provided in this manual, in a place that endures the weight of the analyzer. Installation in an inadequate place may cause turnover or fall, resulting in injury. • Be sure to wear protective gloves when lifting the analyzer. Lifting it with bare hands may result in injury. • Be sure to fix the top cover before transporting the analyzer. Transportation in unstable state may result in injury. • The gas analyzer is heavy. Two or more persons should carry it, while exercising due care. Otherwise unexpected harm to your body or injury may result. • Take care not to let cable chips and other foreign objects enter the unit during installation work. Otherwise fire, failure, or malfunction may result. |

| Caution on piping | |
|---|---|
|  DANGER | <p>Be sure to observe the following precautions while installing piping. Improper piping may result in gas leakage.</p> <p>If the leaking gas contains a toxic component, serious accidents may result. If it contains combustible gases, explosion or fire may result.</p> <ul style="list-style-type: none"> • Connect pipes correctly referring to the instruction manual. • Discharge the exhaust gas outdoors to prevent it from remaining within the sampling device or indoors. • Relieve the exhaust gas from the analyzer to the atmospheric pressure to prevent buildup of undesirable pressure to the analyzer. Otherwise piping within the analyzer may be disconnected, resulting in gas leakage. • Use pipes and pressure reducing valves to which no oil/grease is attached for piping. Otherwise, fire may result. |

| Caution on wiring | |
|--|--|
|  CAUTION | <ul style="list-style-type: none"> • Be sure to turn off the power before installing wiring. Otherwise electric shock may result. • Be sure to perform class D grounding work. Otherwise, electric shock or failure may result. • Select a proper wiring material that satisfies the ratings of the instrument. Otherwise, electric shock or fire may result. • Be sure to connect a power supply of correct rating. Otherwise, fire may result. |

| Caution on use | |
|--|--|
|  DANGER | <ul style="list-style-type: none"> • Be sure to read the instruction manual for reference gases before handling reference gases such as calibration gas to use them properly. |
|  CAUTION | <ul style="list-style-type: none"> • Leaving the analyzer unused for a long time or restarting it after long-term suspension requires procedures different from normal operation or suspension procedures. Be sure to follow the instructions in each instruction manual. Otherwise, intended performance may not be achieved, or accidents or injury may result. • Do not operate the analyzer for a long time with its top cover left open. Otherwise, dust, foreign matter, etc. may stick on internal walls, thereby causing faults. |

| | |
|-----------------------|--|
| Caution on use | |
|-----------------------|--|

| | |
|--|--|
|  PROHIBITION | <ul style="list-style-type: none"> • Do not touch the input/output terminals with metal or finger. Otherwise, electric shock or injury may result. • Do not smoke or use flames near the analyzer. Otherwise, fire may result. • Do not allow water to enter the analyzer. Otherwise, electric shock or internal fire may result. |
|--|--|

| | |
|---|--|
| Caution on maintenance and check | |
|---|--|

| | |
|---|--|
|  DANGER | <ul style="list-style-type: none"> • Before performing work with the cover of the analyzer kept open for maintenance and check, be sure to purge completely not only within the analyzer but also measuring gas lines with nitrogen or air. Otherwise, poisoning, fire, or explosion may result due to gas leakage. |
|---|--|

| | |
|--|--|
|  CAUTION | <p>Be sure to observe the following to perform work safely, avoiding electric shock or injury.</p> <ul style="list-style-type: none"> • Remove the watch and other metallic objects before work. • Do not touch the instrument wet-handed. • If the fuse is blown, eliminate the cause and replace it with the one of the same capacity and type. Otherwise, electric shock or accidents may result. • Do not use replacement parts other than those specified by the manufacturer. Otherwise, intended performance may not be achieved, or accidents or failures may result. • Dispose replacement parts such as maintenance parts as combustibles according to the local waste disposal regulations. |
|--|--|

| | |
|---------------|--|
| Others | |
|---------------|--|

| | |
|--|---|
|  CAUTION | <ul style="list-style-type: none"> • If the cause of a fault cannot be identified by referring to the instruction manual, be sure to contact your dealer or Fuji's technician in charge of adjustment. Disassembling the instrument carelessly may result in electric shock or injury. |
|--|---|

WARRANTY AND MAINTENANCE

1. Scope of application

To use this equipment, the following conditions must be met:

- the use of the equipment incurs no risk of a serious accident even if a failure or malfunction occurs on the equipment, and
- in case of product failure or malfunction, safety measures such as redundant design, prevention of malfunction, fail safe system, foolproof mechanism are provided outside of the equipment.

Be sure to use this instrument under the conditions or environment mentioned in this instruction manual. Please consult us for the use for the following applications:

Radiation-related facilities, systems related to charging or settlement, or other usages which may have large impact on lives, bodies, property, or other rights or interests.

2. Operating conditions and environment

Refer to "Caution on safety" and Section 9, "Specifications".

3. Precautions and prohibitions

Refer to "Caution on safety" and Section 9, "Specifications".

4. Warranty

4-1. Period of warranty

- (1) Warranty period for this product including accessories is one year after delivery.
- (2) Warranty period for the parts repaired by our service providers is six months after the completion of repair.

4-2. Scope of warranty

- (1) If any failure or malfunction attributable to Fuji Electric occurs in the period of warranty, we shall provide the product after repairing or replacing the faulty part for free of charge at the place of purchase or delivery. The warranty does not apply to failure or malfunctions resulting from:
 - 1) inappropriate conditions, environment, handling or usage that is not instructed in a catalog, instruction book or user's manual, or overuse of the product,
 - 2) other devices not manufactured by Fuji Electric,
 - 3) improper use, or an alteration or repair that is not performed by Fuji Electric,
 - 4) inappropriate maintenance or replacement of expendable parts listed in the instruction book or the catalog,
 - 5) damages incurred during transportation or fall after purchase,
 - 6) any reason that Fuji Electric is not responsible for, including a disaster or natural disaster such as earthquake, thunder, storm and flood damage, or inevitable accidents such as abnormal voltage.
- (2) Regardless of the time period of the occurrence, Fuji Electric is not liable for the damage caused by the factors Fuji Electric is not responsible for, opportunity loss of the purchaser caused by malfunction of Fuji Electric product, passive damages, damage caused due to special situations regardless of whether it was foreseeable or not, and secondary damage, accident compensation, damage to products that were not manufactured by Fuji Electric, and compensation towards other operations.

5. Failure diagnosis

Regardless of the time period of the occurrence, if any failure occurs, the purchaser shall perform a primary failure diagnosis. However, at the purchaser's request, Fuji Electric or our service providers shall provide the diagnosis service for a fee. In such a case, the purchaser shall be charged for the service.

6. Service life

This product, excluding limited-life parts and consumable parts, is designed for a service life of 10 years under general operating conditions (with an average ambient temperature of 30°C).

The service life may be shortened depending on operating conditions and environment. To ensure the service life, it is important to perform planned maintenance of the product including limited-life parts and consumable parts.

7. Maintenance plan

Maintenance can be divided into "preventive maintenance" and "corrective maintenance". Preventive maintenance can further be classified into "daily inspection" and "periodic inspection". Preventive maintenance is achieved through systematic implementation of "daily inspection" and "periodic inspection".

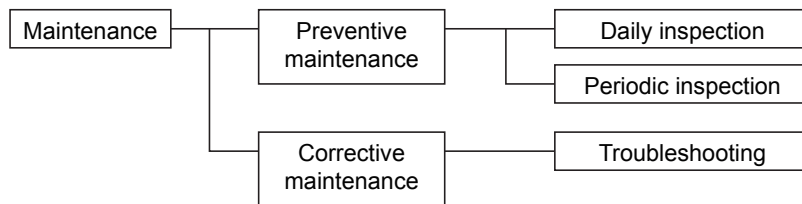

(1) Daily inspection

Be sure to perform daily inspection prior to operation to check for any problem in daily operation. For the specific items of daily inspection, refer to Section 7, "Maintenance".

(2) Periodic inspection

Periodic inspection is to replace limited-life parts before their service lives are over, thus preventing failure. Recommended inspection interval is 6 months to 12 months. If you are using the instrument under harsh environment, we recommend you to shorten the inspection interval. For the specific items of periodic inspection, refer to Section 7, "Maintenance".

(3) Corrective maintenance

Corrective maintenance is a measure to be taken after a trouble has occurred. Refer to Section 7 "Maintenance" and Section 8. "Error messages". If the measures mentioned in this instruction manual do not solve the problem, please contact one of our sales offices or service offices.

8. Limited-life parts and consumable parts

This product contains the following limited-life parts and consumable parts which may affect the service life of the product itself.

(1) Aluminum electrolytic capacitor

- Design life: 5 years under general working conditions (annual average of ambient temperature: 30°C)
- Symptoms when a capacitor loses its capacity: deterioration of power quality, malfunction
- Factors which affect battery life: temperature. The life is shortened by half when the temperature rises by 10°C. (Arrhenius' law)

-
- Replacement: Estimate the lifetime of capacitor according to your operating environment, and have the capacitor replaced or overhauled at appropriate time, at least once in 10 years. Do not use capacitors beyond its lifetime. Otherwise, electrolyte leakage or depletion may cause odor, smoke, or fire. Please contact Fuji Electric or its service providers when an overhaul is required.

(2) LCD

- Design life: approx. three years for continuous use
- Symptoms when LCD is depleted: unclear indication, back light not working
- Factors which affect battery life: temperature. The life is shortened by half when the temperature rises by 10°C. (Arrhenius' law)
- Replacement: Estimate the lifetime of built-in battery according to your operating environment, and replace it at appropriate time.

9. Spare parts and accessories

Refer to "Confirmation of delivered equipment" and/or Section 7 "Maintenance" for spare parts and accessories.

10. Period for repair and provision of spare parts after product discontinuation (maintenance period)

The discontinued models (products) can be repaired for 5 years from the date of discontinuation. Also, most spare parts used for repair are provided for five years from the date of discontinuation. However, some electric parts may not be obtained due to their short life cycle. In this case, repair or provision of spare parts may be difficult even in the above period.

Please contact one of our sales offices or service offices for further information.

CONTENTS

| | |
|--|------|
| PREFACE..... | i |
| CAUTION ON SAFETY | ii |
| WARRANTY AND MAINTENANCE..... | v |
| CONTENTS | viii |
| 1. OVERVIEW..... | 1-1 |
| 2. NAME AND DESCRIPTION OF EACH UNIT..... | 2-1 |
| 2.1 Name and description of main unit..... | 2-1 |
| 2.2 Input/Output terminal module..... | 2-2 |
| 3. INSTALLATION | 3-1 |
| 3.1 Installation conditions..... | 3-1 |
| 3.2 Installation..... | 3-2 |
| 3.2.1 Installation of analyzer main frame | 3-2 |
| 3.2.2 Mounting input/output terminal module..... | 3-3 |
| 3.3 Piping..... | 3-4 |
| 3.4 Sampling | 3-7 |
| 3.4.1 Conditions of sampling gas..... | 3-7 |
| 3.4.2 Sampling gas flow..... | 3-7 |
| 3.4.3 Preparation of standard gas..... | 3-7 |
| 3.4.4 Purging of instrument inside..... | 3-7 |
| 3.4.5 Pressure at sampling gas outlet..... | 3-8 |
| 3.4.6 Example configuration of gas sampling system | 3-8 |
| 3.5 Wiring..... | 3-9 |
| 3.5.1 Power inlet..... | 3-9 |
| 3.5.2 Input/output terminal module | 3-10 |
| 4. OPERATION..... | 4-1 |
| 4.1 Preparation for operation | 4-1 |
| 4.2 Warm-up operation and regular operation | 4-1 |
| 5. DESCRIPTION OF DISPLAY AND OPERATION PANELS..... | 5-1 |
| 5.1 Name and description of operation panel | 5-1 |
| 5.2 Overview of display and operation panels..... | 5-2 |
| 5.3 Outline of display screen..... | 5-3 |
| 5.4 Basic operation..... | 5-6 |
| 6. SETTING AND CALIBRATION..... | 6-1 |
| 6.1 Switch of range | 6-1 |
| 6.1.1 Setting of range switch mode..... | 6-1 |

| | | |
|-------|--|------|
| 6.1.2 | Manual range switch | 6-2 |
| 6.2 | Calibration Setting | 6-3 |
| 6.2.1 | Setting of calibration concentration..... | 6-3 |
| 6.2.2 | Setting of manual zero calibration | 6-5 |
| 6.2.3 | Setting of calibration range..... | 6-7 |
| 6.2.4 | Setting of auto calibration component/range..... | 6-9 |
| 6.3 | Alarm setting..... | 6-11 |
| 6.3.1 | Setting of alarm values | 6-11 |
| 6.3.2 | Hysteresis setting | 6-13 |
| 6.4 | Setting of auto calibration..... | 6-14 |
| 6.4.1 | Auto calibration | 6-14 |
| 6.4.2 | Forced run/stop of auto calibration..... | 6-17 |
| 6.5 | Setting of auto zero calibration | 6-20 |
| 6.5.1 | Auto zero calibration | 6-20 |
| 6.5.2 | Forced run/stop of auto zero calibration..... | 6-22 |
| 6.6 | Peak count alarm setting | 6-25 |
| 6.7 | Parameter setting..... | 6-27 |
| 6.8 | Maintenance mode | 6-35 |
| 6.9 | Manual calibration procedure | 6-41 |
| 6.9.1 | Manual zero calibration | 6-41 |
| 6.9.2 | Manual span calibration..... | 6-42 |
| 7. | MAINTENANCE | 7-1 |
| 7.1 | Daily check | 7-1 |
| 7.2 | Daily check and maintenance procedures..... | 7-1 |
| 7.3 | Maintenance of analyzer unit..... | 7-2 |
| 7.3.1 | Cleaning method for sample cell (pipe cell)..... | 7-2 |
| 7.3.2 | Cleaning method for sample cell (block cell)..... | 7-4 |
| 7.3.3 | Optical zero adjustment method (optical balance adjustment)..... | 7-6 |
| 7.3.4 | Moisture interference compensation adjustment method | 7-7 |
| 7.4 | Long term maintenance..... | 7-9 |
| 7.5 | Replacement of fuse..... | 7-10 |
| 8. | ERROR MESSAGE..... | 8-1 |
| 9. | SPECIFICATIONS | 9-1 |
| 9.1 | General specifications | 9-1 |
| 9.2 | Code symbols..... | 9-4 |
| 9.3 | Measurable component and range | 9-6 |
| 9.4 | Outline diagram | 9-8 |

1. OVERVIEW

This infrared gas analyzer (type: ZKJ) measures the concentration of NO, SO₂, CO₂, CO and CH₄ contained in sampling gas on the principle that different atomic molecules have an absorption spectrum in the wave band of infrared rays, and the intensity of absorption is determined by the Lambert-Beer law.

Since this instrument incorporates a compact paramagnetic O₂ sensor, it allows measuring up to 5 components simultaneously by using the built-in O₂ sensor (up to 4 components if O₂ sensor is excluded).

Furthermore, use of a microprocessor or large sized liquid crystal display realizes improvement of operability, accuracy and multi-functions.

This instrument is optimum for measuring combustible gas exhausted from boilers or incinerators, and it is effective for steel gas analysis (blast furnace, steel converter, thermal treatment furnace, sintering (Pellet equipment), coke furnace), storage and maturity of vegetable and fruit, biochemistry (microbe), [fermentation], air pollution [incinerator, exhaust gas desulfurization, denitration], automotive emission (excluding tester), protection against disasters [detection of explosive gas and toxic gas, combustion gas analysis of new building material], growth of plants, chemical analysis [petroleum refinery plant, petroleum chemistry plant, gas generation plant], environment [landfill concentration, tunnel concentration, parking lot, building management] and various physical and chemical experiments.

2. NAME AND DESCRIPTION OF EACH UNIT

2.1 Name and description of analyzer main unit

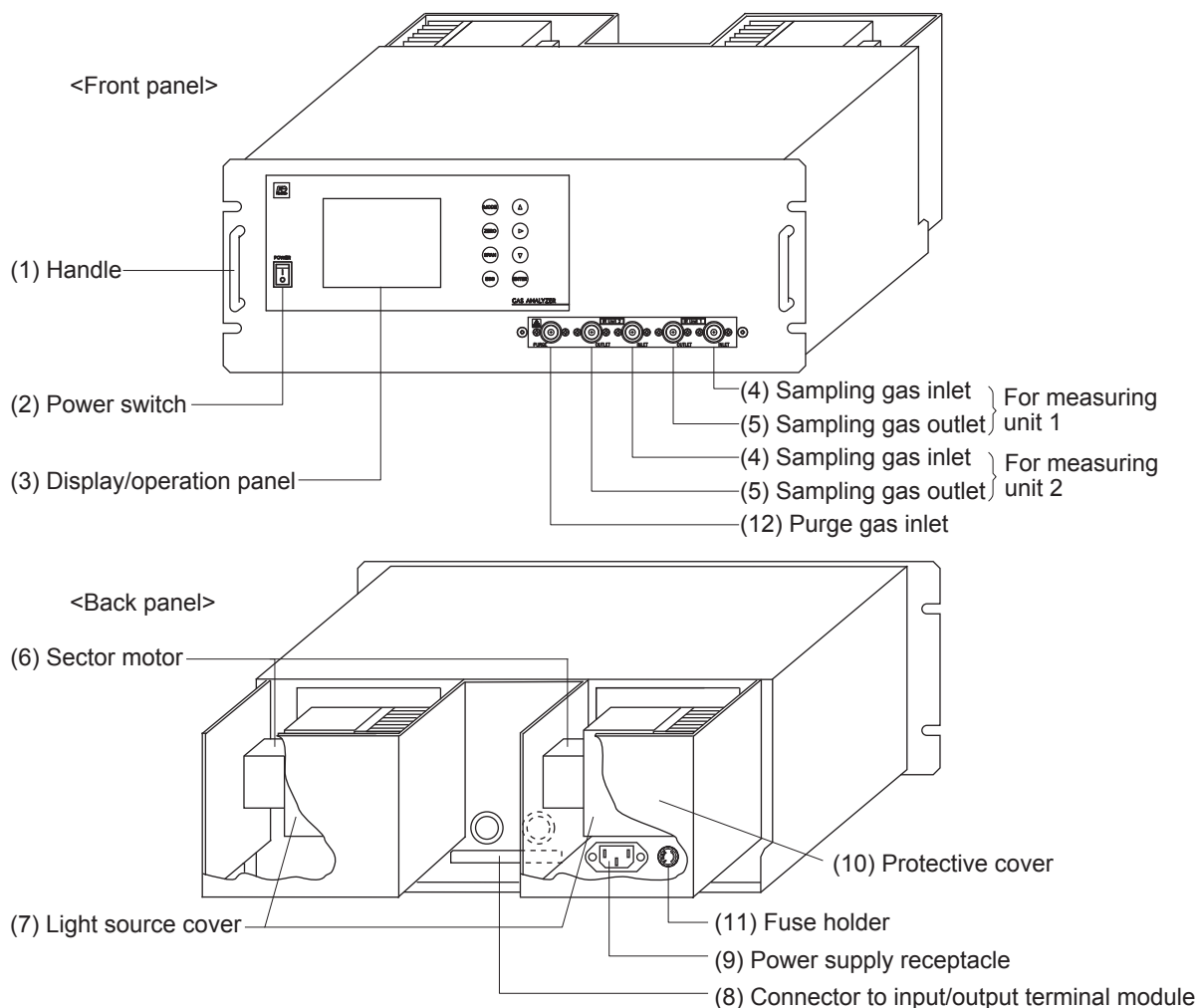

Fig. 2-1

| Name | Description | Name | Description |
|-----------------------------|---|---|---|
| (1) Handle | Used for withdrawing the main unit from the panel. | (7) Light source cover | Infrared light source is arranged in the cover. |
| (2) Power switch | Used for ON/OFF the analyzer. | (8) Connector to input/output terminal module | For connecting to the external input/output terminal module |
| (3) Display/operation panel | Liquid crystal display and keys for setting various functions | (9) Power inlet | For connecting the power cord |
| (4) Sampling gas inlet | For connecting to the measuring gas tube | (10) Protective cover | Protective cover for the light source and the motor. May be removed during operation. |
| (5) Sampling gas outlet | Connect to the exhaust line. (A pair of sampling gas inlet/outlet is provided for each measuring unit.) | (11) Fuse holder | 250V. T.3. 15A.L |
| (6) Sector motor | For driving the rotation of sector | (12) Purge gas inlet | For purging the inside of the total gas analyzer |

2.2 Input/Output terminal module

This analyzer provides input/output of various signals from the supplied input/output terminal module by connecting the analyzer main unit to this module.

<Input/Output terminal module>

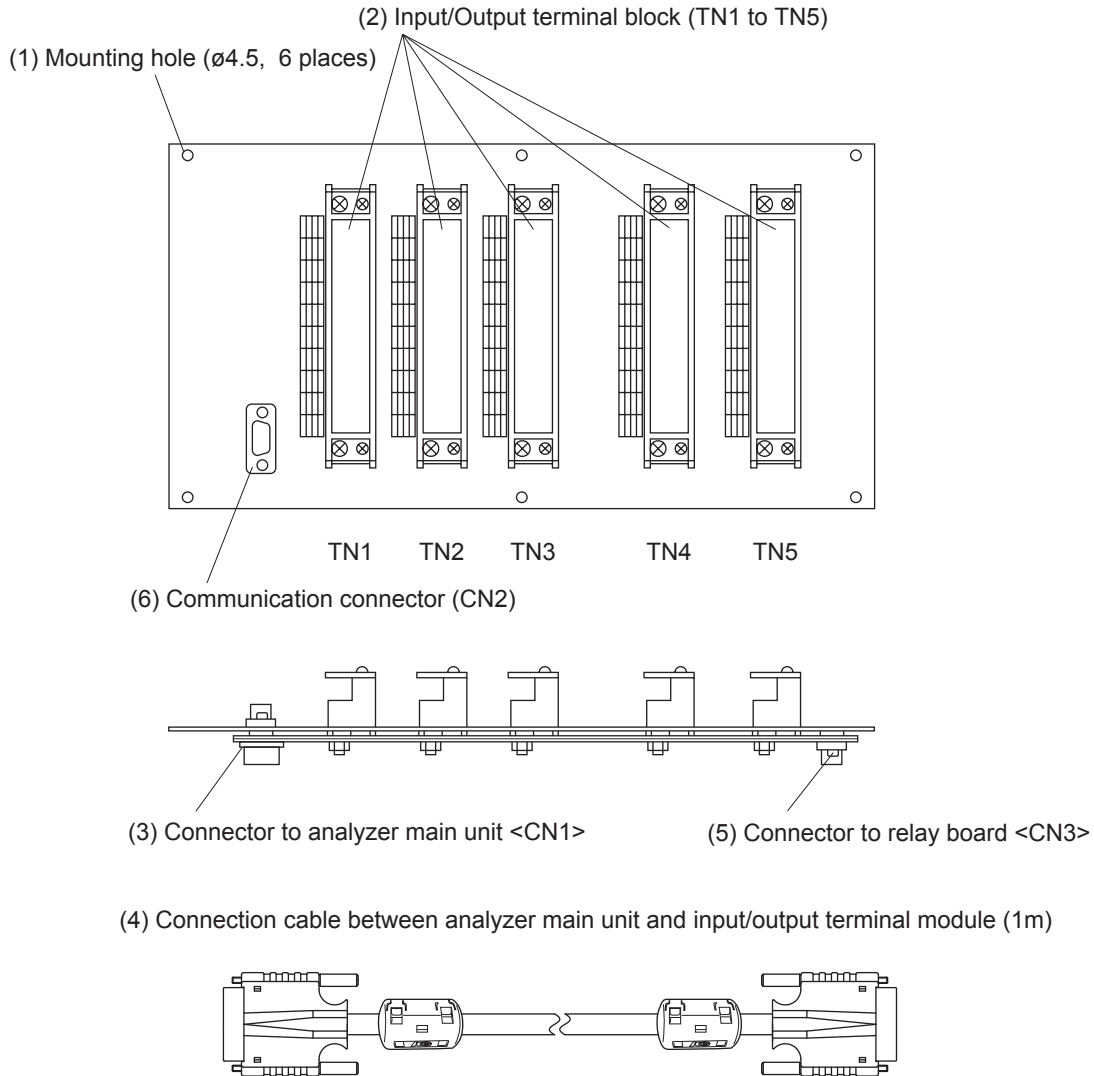

Fig. 2-2

| Name | Description | Name | Description |
|--|--|--|--|
| (1) Mounting hole | Used for mounting input/output terminal module. ø 4.5, 6 places | (4) Connection cable between analyzer main unit and input/output terminal module | Used for connecting the analyzer main unit to the input/output terminal module. |
| (2) Input/output terminal block (TN 1 to TN 5) | Input/output terminal for signals of analog output, range identification contact, alarm contact output, etc. | (5) Connector to relay board <CN3> | Cable connector for connecting the analyzer to the relay board for automatic calibration. |
| (3) Connector to analyzer main unit <CN1> | Used for connecting the analyzer main unit and the input/output terminal module (4). | (6) Communication connector <CN2> | Connect communication cable. *Please refer to another manual (INZ-TN5A2964-E) about communication function. |

3. INSTALLATION

⚠ DANGER

This unit is not explosion-proof type. Do not use it in a place with explosive gases to prevent explosion, fire or other serious accidents.

⚠ CAUTION

- Entrust the installation, movement or re-installation to a specialist or the supplier. A poor installation may cause accidental tipover, electric shock, fire, injury, etc.
- The gas analyzer is heavy. It should be installed with utmost care. Otherwise, it may tipover or drop, for example, causing accident or injury.
- For lifting the gas analyzer, be sure to wear protective gloves. Bare hands may invite an injury.
- This unit should be installed in a place which conforms to the conditions noted in the instruction manual. Otherwise, it may cause electric shocks, fire or malfunction of the unit.
- During installation work, care should be taken to keep the unit free from entry of cable chips or other foreign objects. Otherwise, it may cause fire, trouble or malfunction of the unit.

3.1 Installation conditions

To install the analyzer for optimum performance, select a location that meets the following conditions;

- (1) This instrument is system built in type. This instrument should be used while embedded in a panel, locker, or enclosure of steel sheet.

Keep a minimum clearance of 10 cm above the analyzer for heat dissipation. The same clearance is required for each analyzers when you install several units on a multistage rack.

- (2) Use this instrument indoors.
- (3) A vibration-free place
- (4) A place which is clean around the analyzer.
- (5) Power supply

| | |
|-------------------|-------------------|
| Rated voltage | : 100V to 240V AC |
| Operating voltage | : 85V to 264V AC |
| Rated frequency | : 50/60 Hz |
| Power consumption | : 250 VA max. |

- (6) Operation conditions

| | |
|-----------------------|------------------------------------|
| Ambient temperature | : -5° to 45°C |
| Ambient humidity | : 90 % RH or less, no condensation |
| Altitude | : Up to 2,187 yard (2,000m) |
| Installation category | : II |
| Pollution Degree | : 2 |

- (7) Maintenance space

When analyzer is installed by itself, please make sure to keep the space shown in the dimension of the figure for maintenance. In case analyzer is installed as an unit, please refer to the instruction manual of the analyzer unit.

- (8) A switch or a circuit-breaker should be included in the installation.
- (9) A breaker should be installed near the analyzer where an operator can access it.
- (10) A label that clearly identifies the breaker should be placed on it.
- (11) The breaker rating should meet the analyzer rating max 3.15A and a breaker should conform to all necessary approvals.

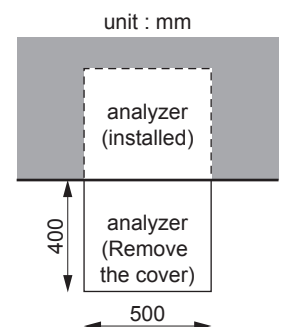

3.2 Installation

3.2.1 Installation of analyzer main frame

Installation methods for the analyzer main unit are divided into 2 types;

(unit: mm)

| Type | External dimensions | Mounting dimensions | Mounting method |
|---|---------------------|---------------------|-----------------|
| 19 inch rack mounting guide rail method | | | |
| 19 inch rack mounting slide rail method | | | |

Note 1 Check and maintenance of the analyzer main unit may be carried out with the top cover detached. The guide rail method may be used if a space accessible for maintenance is provided at the top of the main unit. If maintenance space is not provided specially, it is recommended to use the slide rail method.

Recommended slide rail: Product No.: 3532-24 manufactured by Sugatsune Kogyo Co., Ltd.

Note 2 For 19 inch rack mounting, the weight of the analyzer is supported with the bottom of the case (with the side of the case in case of slide rail method). For mounting dimensions of the slide rail, see "Section 9.4 Outline diagram".

Don't install the analyzer at a place which is exposed to direct sunlight.

The analyzer should be installed at a place where ambient temperature is within -5 to 45°C , and temperature fluctuation during use is minimum.

3.2.2 Mounting input/output terminal module

Mount the input/output terminal module on the panel; observing the following method.

(Note) To avoid the effect of noise generated from external units, mount the I/O terminal module mounting plate on the panel for continuity at the mounting surface and connect the panel to the same ground as the analyzer main unit.

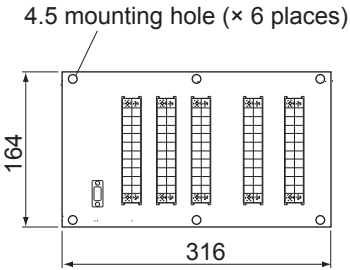
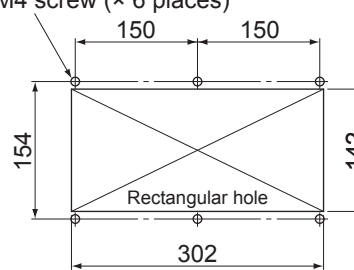
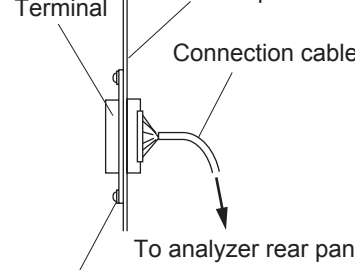
| External dimensions | Mounting dimensions | Mounting method |
|---|--|--|
|  <p>4.5 mounting hole (× 6 places)</p> <p>164</p> <p>316</p> |  <p>M4 screw (× 6 places)</p> <p>150</p> <p>150</p> <p>154</p> <p>142</p> <p>302</p> <p>Rectangular hole</p> |  <p>Terminal</p> <p>Panel plate</p> <p>Connection cable</p> <p>To analyzer rear panel</p> <p>Screwed to panel</p> |

Note) How to ground analyzer main unit and I/O terminal module

To avoid the effect of noises, etc. from external units, it is recommended to ground them by the procedure described below.

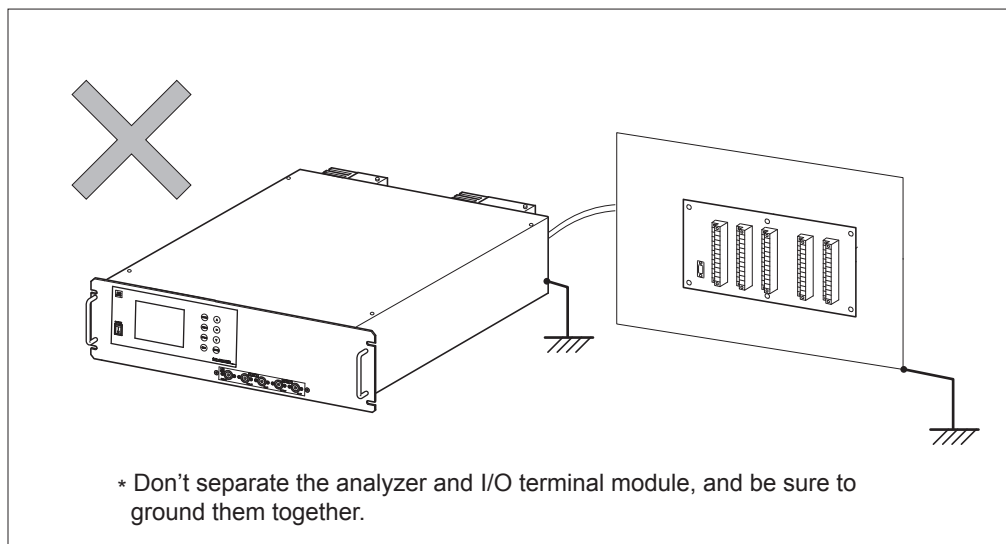
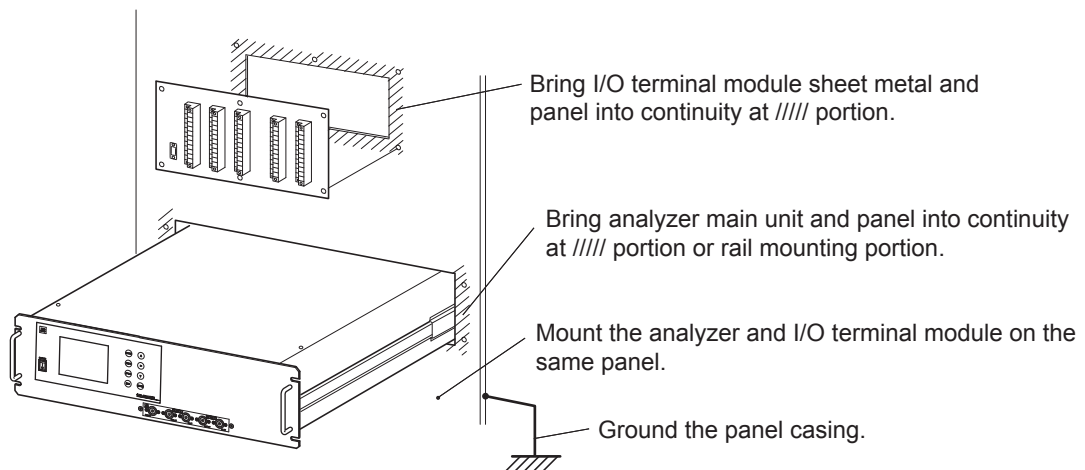

3.3 Piping

CAUTION

The analyzer ZKJ has two inlets for sample gas, two outlets for sample gas, and purge gas inlet. Improper connection may cause accumulation of combustible, toxic, and/or explosive gas in the analyzer. Be sure to connect each pipe correctly.

Observe the following when connecting the gas tube.

- Piping should be connected to the gas inlets and outlets on the front panel of the analyzer.
- Use a corrosion resistant tube of Teflon, stainless or polyethylene to connect the analyzer to a sampling system. Even if there is no danger of corrosion, refrain from using a tube of rubber or soft vinyl. The analyzer provides inaccurate indication due to gas absorption by piping materials.
- Pipe connection port is Rc1/4 female thread (or NPT1/4). Piping should be cut as short as possible for a quick response. About 4 mm inner diameter is recommended.
- Entry of dust into the analyzer may result in malfunction. Use a clean piping or coupling.

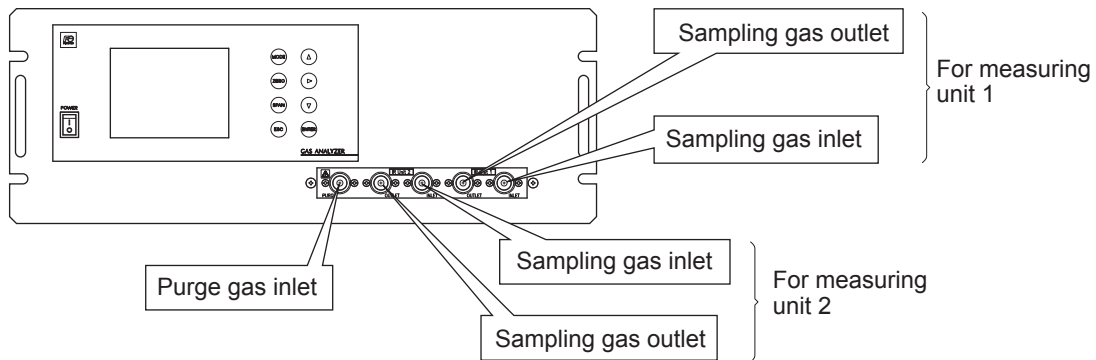

Sampling gas inlet: Attach the gas tube to introduce gas to be measured such as one that has completed dehumidification process and standard gases for zero and span calibration to this inlet.

Gas flow to be introduced should be constant within the range of 0.5 L/min \pm 0.2 L/min.

Sampling gas outlet: Exhaust measured gas through the outlet. Attach the tube to exhaust measured gas outdoors or to the atmosphere.

Purge gas inlet: It is used for purging the inside of the total gas analyzer. When the analyzer must be purged, refer to Section 3.4.4 Purging of instrument inside.

Use dry gas N₂ or instrumentation air for purge gas. (flow rate of 1L/min or more).

Internal piping diagram

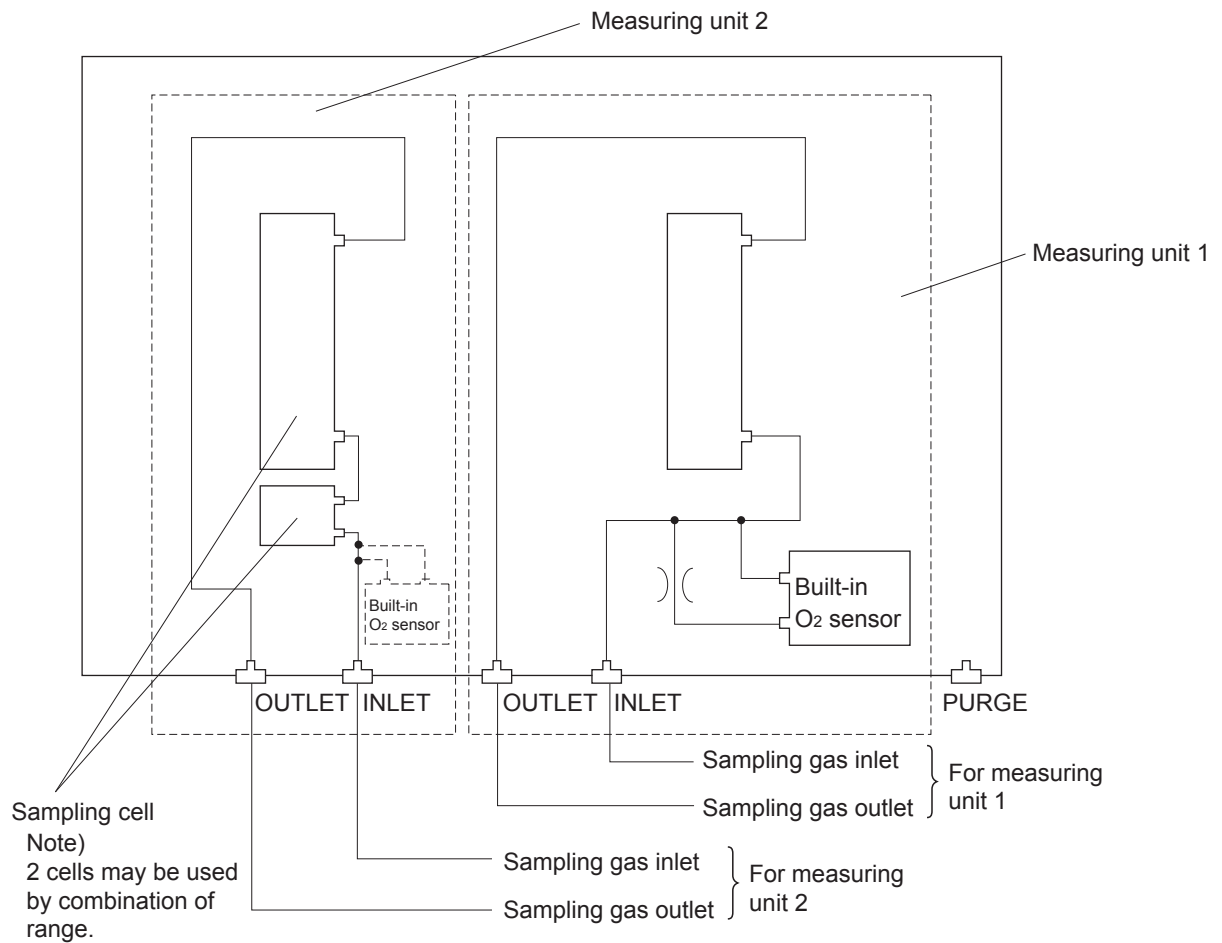

Correspondence of measured components and measuring units

| Measured components | Measuring unit 1 | Measuring unit 2 |
|--|--|---|
| 1-component analyzer for NO, SO ₂ , CO ₂ , CO, CH ₄ or N ₂ O | Each measured component | None |
| 2-component analyzer for NO/SO ₂ , CO ₂ /CO, N ₂ O/CO ₂ | NO/SO ₂ , CO ₂ /CO, N ₂ O/CO ₂ | None |
| 2-component analyzer for NO/CO | NO | CO |
| 3-component analyzer for NO/SO ₂ /CO, N ₂ O/CO ₂ /CO | NO/SO ₂ , N ₂ O/CO ₂ | CO |
| 3-component analyzer for NO/N ₂ O/CO ₂ , SO ₂ /N ₂ O/CO ₂ , CH ₄ /N ₂ O/CO ₂ | NO, SO ₂ , CH ₄ | N ₂ O/CO ₂ |
| 3-component analyzer for NO/SO ₂ /CO | NO/SO ₂ | CO |
| 4-component analyzer for NO/SO ₂ /CO ₂ /CO, NO/SO ₂ /N ₂ O/CO ₂ | NO/SO ₂ | CO ₂ /CO, N ₂ O/CO ₂ |

Note) When there are two measuring units, the built-in O₂ sensor must be connected to the measuring unit 2.

Example of connecting each measuring unit

- One pair of gas inlet/outlet

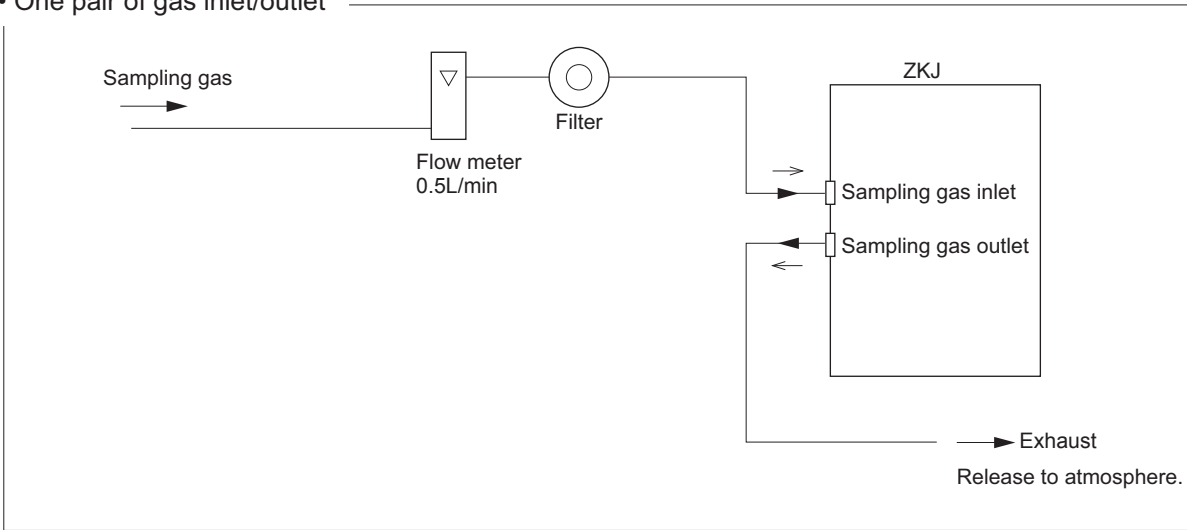

- Two pair of gas inlet/outlet - (1)

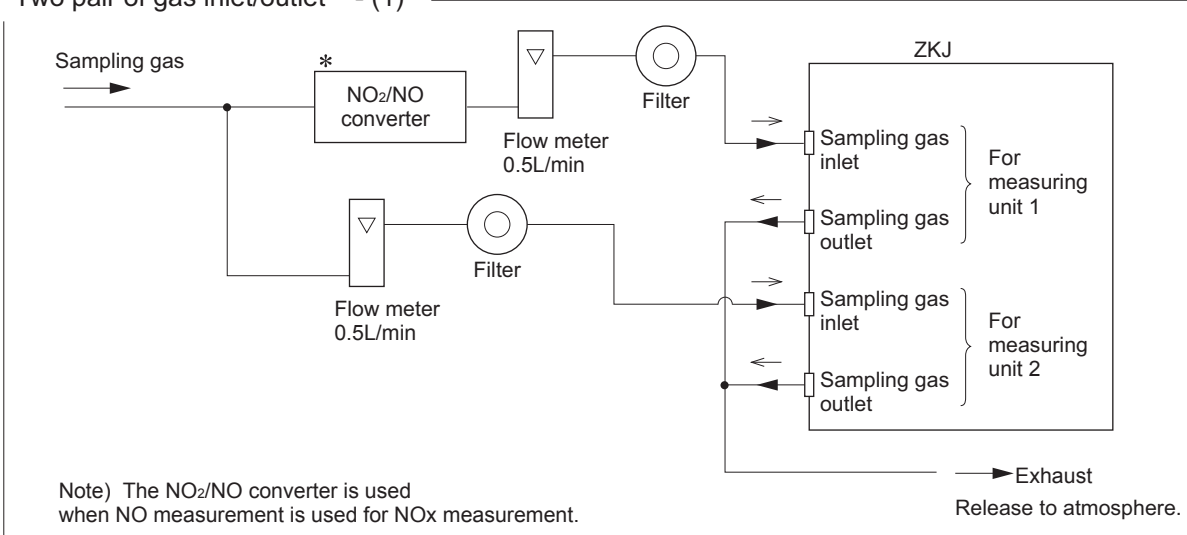

- Two pair of gas inlet/outlet - (2)

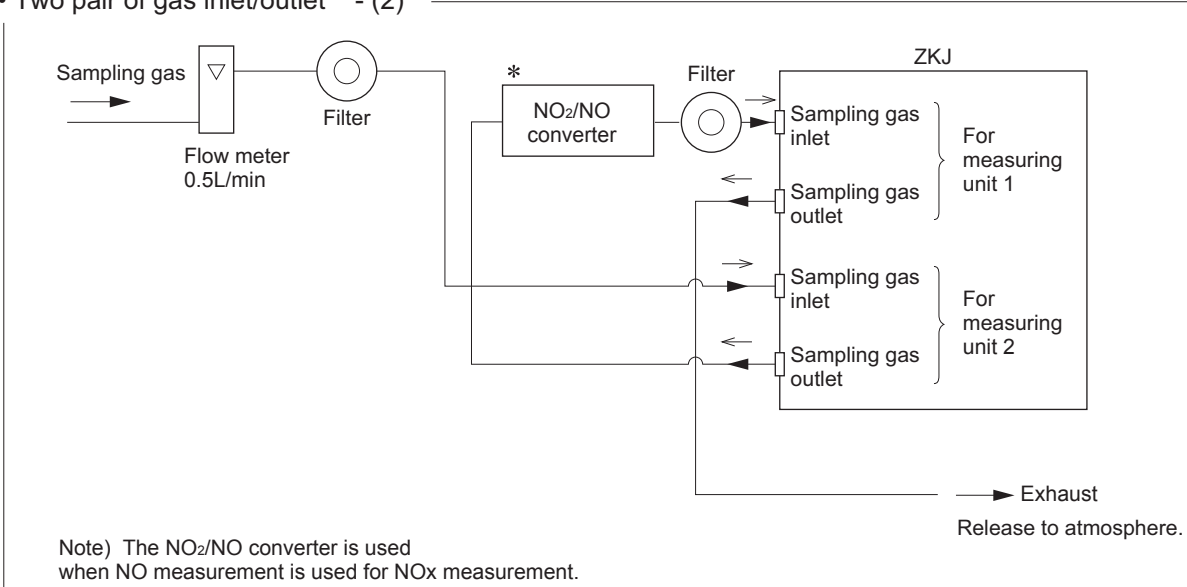

3.4 Sampling

3.4.1 Conditions of sampling gas

- (1) Dust contained in the sampling gas should be completely removed with a filter. For the final stage filter, use a filter that allows removing dust particles of 0.3 μ m.
- (2) Dew point of sampling gas must be lower than the ambient temperature to avoid occurrence of drain in the gas analyzer. If vapor is contained in the sampling gas, dew point should be lowered to 0°C by using a dehumidifier.
- (3) If SO₃ mist is contained in the sampling gas, use a mist filter or cooler to remove SO₃ mist. Other mists should be removed by using a mist filter or cooler.
- (4) Corrosive gases such as Cl₂, F₂ and HCl, if they are contained in the sampling gas in considerable amounts, will shorten the life of instruments.
- (5) Temperature of sampling gas should be within 0 to 50°C. Provide a means that prevents entry of hot gas directly into the instrument.

3.4.2 Sampling gas flow

Flow of sampling gas should be 0.5L/min \pm 0.2L/min.

Avoid flow fluctuation during measurement.

Observe the flow reading by a flowmeter provided as shown in the example of the sampling system configuration (Section 3.4.6).

3.4.3 Preparation of standard gas

Routine calibration is required by standard gas for keeping this instrument under normal operation condition (once a week). Prepare a standard gas cylinder for zero calibration and span calibration.

| | Analyzer without O ₂ measurement | Analyzer with built-in O ₂ sensor | Analyzer with external zirconia O ₂ sensor |
|--|---|--|--|
| Zero gas | N ₂ gas or dry air | N ₂ gas | Dry air, atmospheric air, or gas with a concentration of 80% or more of full scale |
| Span gas other than for O ₂ measurement | Gas with concentration of 90% or more of full scale | Gas with concentration of 90% or more of full scale | Gas with concentration of 90% or more of full scale |
| Span gas for O ₂ measurement | _____ | Gas with concentration of 90% or more of full scale or atmospheric air (21%) | 1 to 2% O ₂ |

In the case of CO₂ analyzer, zero gas shall not contain CO₂ gas if the concentration of CO₂ in atmospheric air is considerable.

3.4.4 Purging of instrument inside

The inside of instrument need not be purged generally except for the following cases.

- (1) A combustible gas component is contained in sampling gas.
- (2) Corrosive gas is contained in the atmospheric air at the installation site.
- (3) The same gas as the sample gas component is contained in the atmospheric air at the installation site.

In such cases as above, the inside of analyzer should be purged with the air for instrumentation or N₂.

Purging flow rate should be about 1L/min.

If dust or mist is contained in purging gas, it should be eliminated completely in advance.

3.4.5 Pressure at sampling gas outlet

Pressure at the sampling gas outlet should be adjusted to atmospheric pressure.

3.4.6 Example configuration of gas sampling system

The following illustrates a typical system configuration for five component gas measurement for monitoring combustion exhaust gas from boiler, refuse incinerator, etc.

Contact Fuji Electric for system configuration matching the particular use or further information.

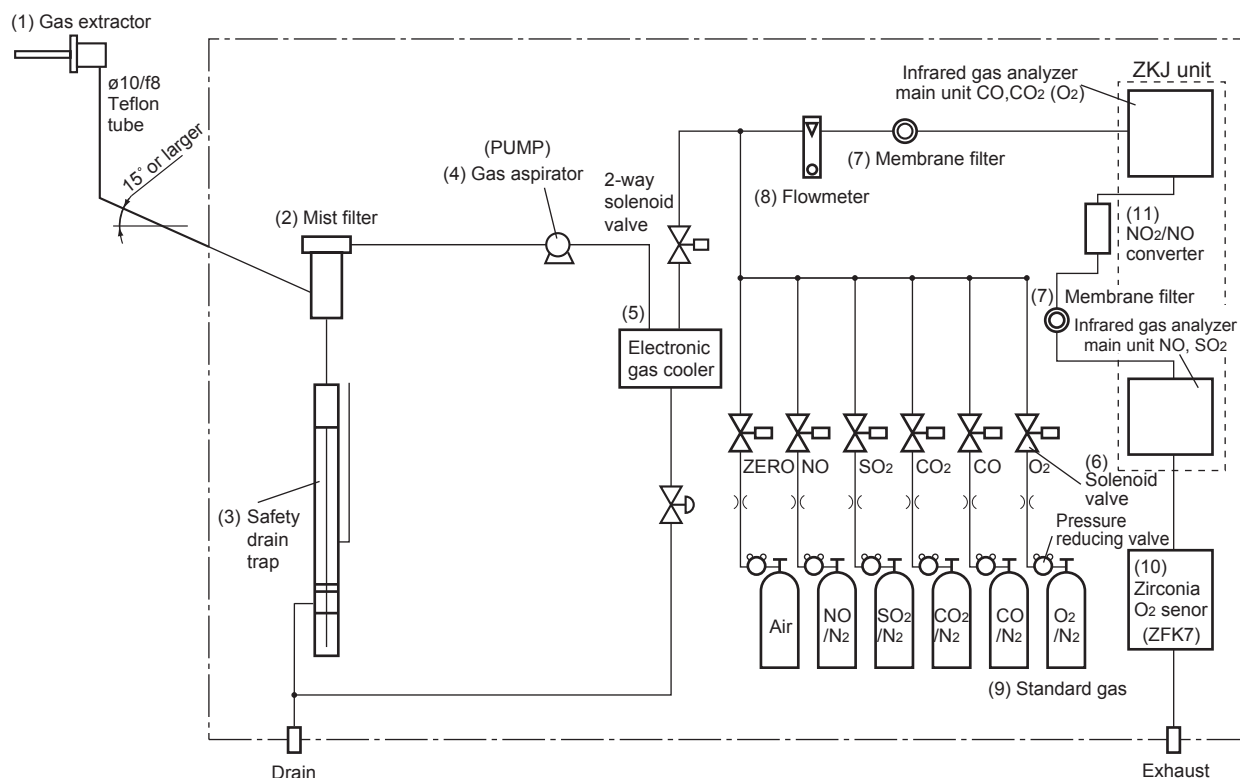

| Name | Description | Name | Description |
|---------------------------|---|-------------------------------------|--|
| (1) Gas extractor | Gas extractor with a heating type stainless steel filter of standard mesh 40 μ m | (7) Membrane filter | PTFE filter used to eliminate fine dust particles and permit monitoring of dust adhering condition on the front panel of the gas analyzer. |
| (2) Mist filter | Removes drain, mist, and dust. | (8) Flowmeter | Adjusts and monitors the flow rate of sampling gas. |
| (3) Safety drain trap | The safety drain trap divided into two rooms for positive and negative pressure. It monitors and adjusts the sampling gas pressure. | (9) Standard gas | Reference gas used for calibrating zero and span of the analyzer. Total 6 cylinders required for zero gas air, span gas NO, SO ₂ , CO, CO ₂ and O ₂ . |
| (4) Gas aspirator (PUMP) | For aspiration of sampling gas | (10) Zirconia O ₂ sensor | External zirconia oxygen sensor used for measuring the oxygen concentration in sample gas. (This is not necessary in case when O ₂ sensor is built-in.) |
| (5) Electronic gas cooler | Dries the moisture in sampling gas to a dew point of approx. 2°C. | (11) NO ₂ /NO converter | Added to NO _x analyzer. A special catalyst material for efficient conversion of NO ₂ gas to NO is used. |
| (6) Solenoid valve | Used for introducing calibration gas. | | |

3.5 Wiring

⚠ CAUTION

- Be sure to turn off the power before wiring. Otherwise, electric shock may result.
- Be sure to perform protective earth connection. Otherwise, electric shock or failure may result.
- Select a proper wiring material that satisfies the ratings of the instrument. Otherwise, electric shock or fire may result.
- Be sure to connect a power supply of correct rating. Otherwise, fire may result.

⚠ CAUTION

⚡ Electric Shock

Please be sure to make ground (grounding) connection for safety.

3.5.1 Power inlet

The power inlet is provided at the rear panel of analyzer main unit.

When using supplied power cord, connect the female side to the power inlet, and insert the male side into a receptacle matching the rating.

⚠ CAUTION

The fuse of the analyzer is wired only to the LIVE side of the single-phase two-wire AC power supply (single cutting).

When connecting the supplied power cord to a power outlet, adjust the polarity.

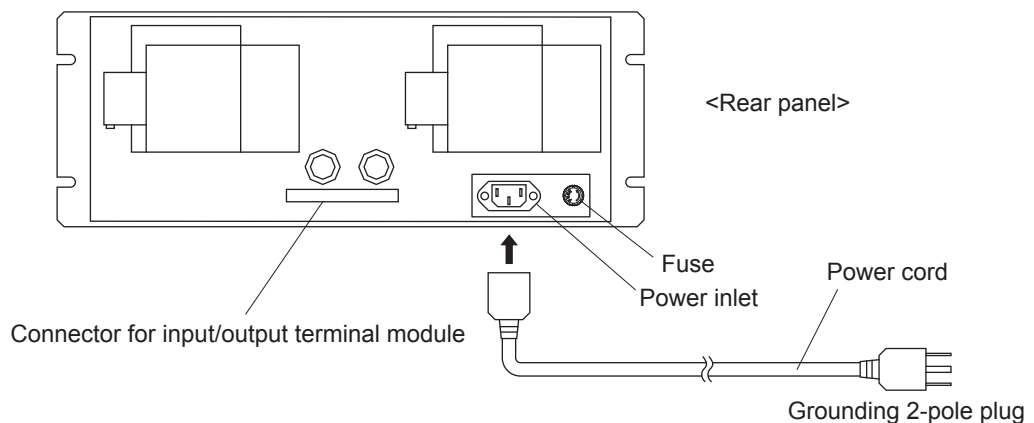

When noise source is in the vicinity

- Avoid installing this instrument near an electrical unit (high frequency furnace or electric welder) that generates much electrical noise. If using the instrument near such a noise generating unit is unavoidable, use a different power line to avoid noise.
- Mount a noise suppressor such as varistor or spark killer as shown at right figure to the noise generating unit when noise is generated from relays or solenoid valves. Mount the suppressor near the noise generating source, or it will have no effect.

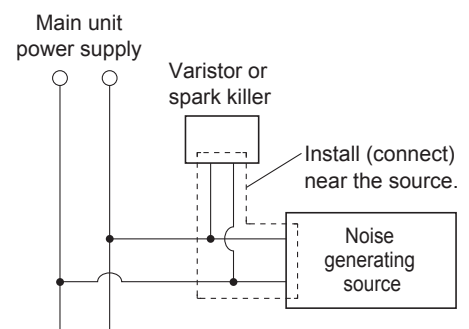

3.5.2 Input/output terminal module

This analyzer should be connected to the input/output terminal module by supplied dedicated cable.

Plug this cable connector into the receptacle at the rear panel of the analyzer and the receptacle on the PCB of the input/output module.

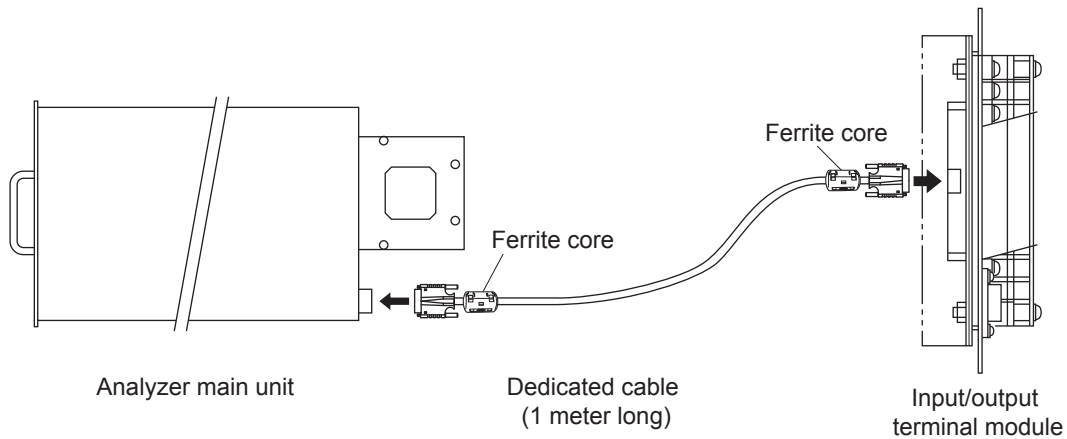

(1) Analog output signal (AO): terminal block 1 (1) to (20), terminal block 2 (3) to (6)

Output signal: 4 to 20 mADC or 0 to 1 VDC (selected when ordering)

Minus lines for the signal are common. And they are insulated from the ground and internal circuit.

Allowable load: 4 to 20 mADC, 550 Ω or less

0 to 1 VDC, 100k Ω or more

- Analog output is provided from each terminal corresponding to the channel displayed in the measurement screen.

CAUTION

All of analog output signals for the instrument are mutual not isolated. It is recommended to isolate signals individually to prevent interference from unnecessary signals or to prevent external interference, especially leading the cable of more than 30 meters or to outdoor.

(2) O₂ sensor input: terminal block 2 (1) – (2)

Input signal:

External zirconia O₂ analyzer: Zirconia O₂ sensor signal (Fuji ZFK7 output)

External O₂ analyzer: 0 to 1 VDC (DC input resistor of 1MΩ or more)

- It is used when the external zirconia O₂ analyzer or external O₂ analyzer is specified as order.
- To connect to the output of the external Zirconia analyzer or external O₂ analyzer prepared separately.
- In case of an external O₂ analyzer, input a signal of 0 to 1 VDC with respect to O₂ full scale of the analyzer.
- In case of built-in O₂ analyzer, do not use this terminals.

 **CAUTION**

O₂ sensor input is not isolated. It is recommended to isolate when an external O₂ analyzer is installed apart from this analyzer. Zirconia O₂ sensor Fuji make ZFK7 should be installed at a location that is as close to this instrument as possible.

(3) Contact input (DI): terminal block 2 (11) to (20), terminal block 3 (3) to (10)

- It is for a contact input at no voltage. An input is provided when switching to short circuit (on) or open (off).
- No voltage is applied to the terminals.

(4) Contact output (DO): terminal block 3 (11) to (20), terminal block 4 and terminal block 5

- Contact rating: 250VAC/2A, load resistance
- An output is for a relay contact output. An output is provided when switching to conductive (on) or open (off).

 **CAUTION**

Wiring of analog output signal, O₂ sensor input and contact input should be fixed separately from the wiring of power supply and contact output.

 **CAUTION**

To avoid the effect of noise generated from external units, be sure to ground the analyzer main unit. Conductive between the I/O module mounting plate and the panel and connect the panel casing to the same ground as the analyzer.

(5) List of terminal blocks

Terminal block 1
<TN1>

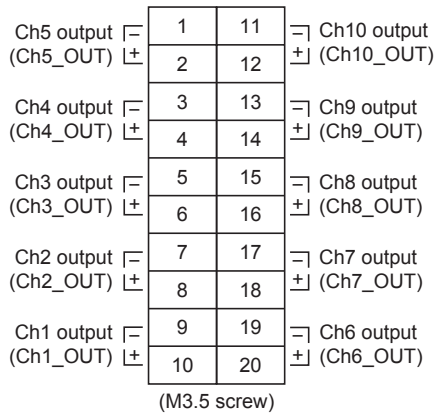

Terminal block 2
<TN2>

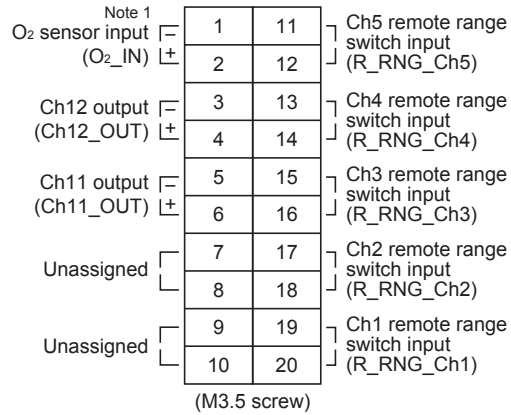

Note 1 : For external O₂ sensor input.

Terminal block 3
<TN3>

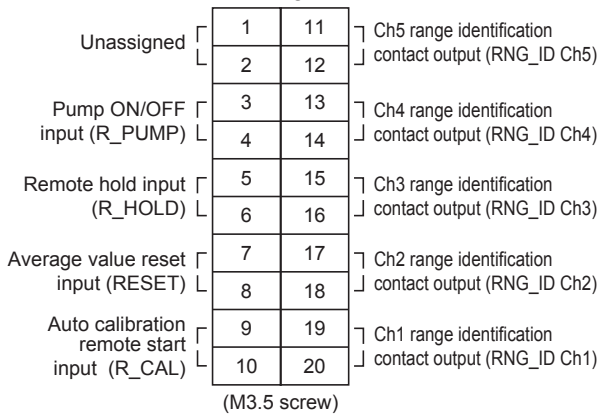

Terminal block 4
<TN4>

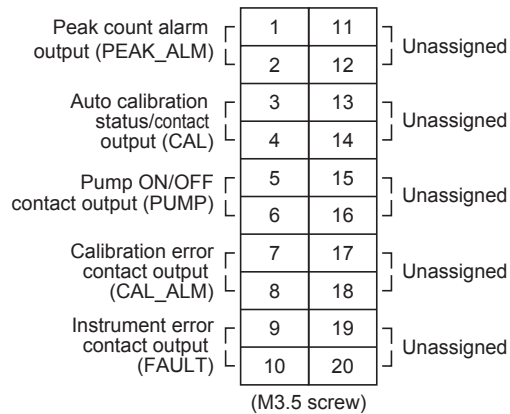

Terminal block 5
<TN5>

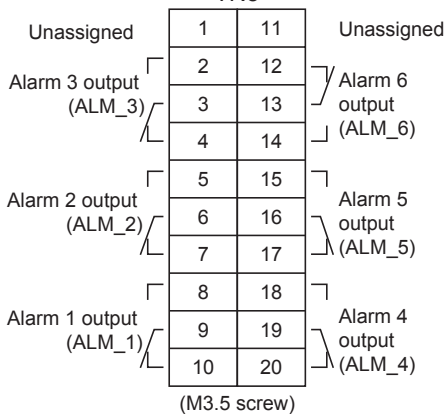

Connector
<CN3>

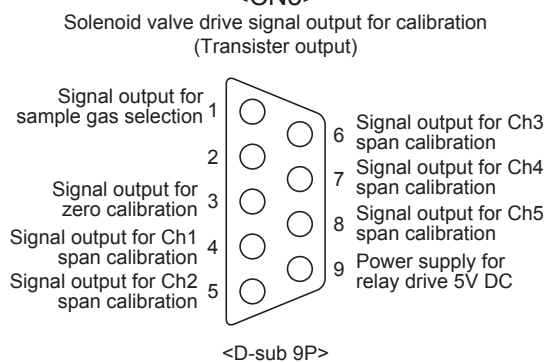

Connector
<CN2>

For serial communication (D-Sub9pin)

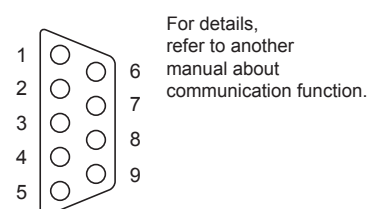

Please do not use unassigned terminals as repeating terminals either because these are used for internal connection.

(6) Description on terminal block

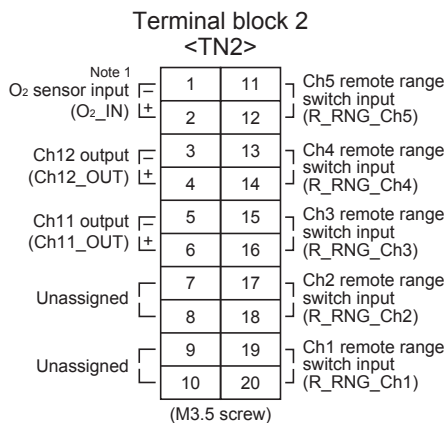
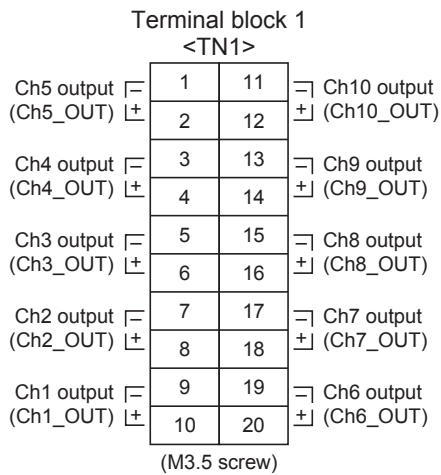

Note 1: For external O₂ sensor input.

Terminal block 1 <TN1>

Terminal block for analog output (non-isolated output)

- Between 1–2 : Ch5 output
- Between 3–4 : Ch4 output
- Between 5–6 : Ch3 output
- Between 7–8 : Ch2 output
- Between 9–10 : Ch1 output
- Between 11–12 : Ch10 output
- Between 13–14 : Ch9 output
- Between 15–16 : Ch8 output
- Between 17–18 : Ch7 output
- Between 19–20 : Ch6 output

Terminal block 2 <TN2>

- Between 1–2 : O₂ sensor input
(For input of Fuji's zirconia oxygen sensor or externally oxygen sensor. Must not be used unless external O₂ sensor is provided.)
- Between 3–4 : Ch12 output
- Between 5–6 : Ch11 output
- Between 7–10 : For internal connection. Must not be wired. (Must not be used as junction terminal).
- Between 11–12: Ch5 remote range switch input
- Between 13–14: Ch4 remote range switch input
- Between 15–16: Ch3 remote range switch input
- Between 17–18: Ch2 remote range switch input
- Between 19–20: Ch1 remote range switch input

Action of remote range switch
High range is selected when open.
Low range is selected when short-circuited.

| Terminal block 3 <TN3> | | | |
|---|----|----|---|
| Unassigned | 1 | 11 | Ch5 range identification contact output (RNG_ID Ch5) |
| | 2 | 12 | |
| Pump ON/OFF input (R_PUMP) | 3 | 13 | Ch4 range identification contact output (RNG_ID Ch4) |
| | 4 | 14 | |
| Remote hold input (R_HOLD) | 5 | 15 | Ch3 range identification contact output (RNG_ID Ch3) |
| | 6 | 16 | |
| Average value reset input (RESET) | 7 | 17 | Ch2 range identification contact output (RNG_ID Ch2) |
| | 8 | 18 | |
| Auto calibration remote start input (R_CAL) | 9 | 19 | Ch1 range identification contact output (RNG_ID Ch1) |
| | 10 | 20 | |

(M3.5 screw)

Terminal block 3 <TN3>

Between 1–2 : For internal connection. Must not be wired. (Must not be used as junction terminal.)

Between 3–4 : Pump ON/OFF input. Pump on when open. Pump off when short-circuited.

Between 5–6 : Remote hold input. No hold when open. Output hold when short-circuited.

For details, refer to “Section 6.7 Parameter setting, Output Hold”.

Between 7–8 : Average value reset input. short-circuiting the contact input (for at 1.5 sec min.) resets O₂ average and O₂ converted average simultaneously. Opening it restarts the average value.

For details, refer to “Section 6.7 Parameter setting, Average Value Resetting”

Between 9–10 : Automatic calibration remote start input

After shorting for 1.5 sec. or more, automatic calibration is started by the opening input whether the automatic calibration setting is ON/OFF.

For details, refer to “Section 6.4 Setting of auto calibration”

Between 11–12: Ch5 range identification contact output

Between 13–14: Ch4 range identification contact output

Between 15–16 Ch3 range identification contact output

Between 17–18: Ch2 range identification contact output

Between 19–20: Ch1 range identification contact output

Action of range identification signal

Range identification contact is conductive at low range and open at high range.

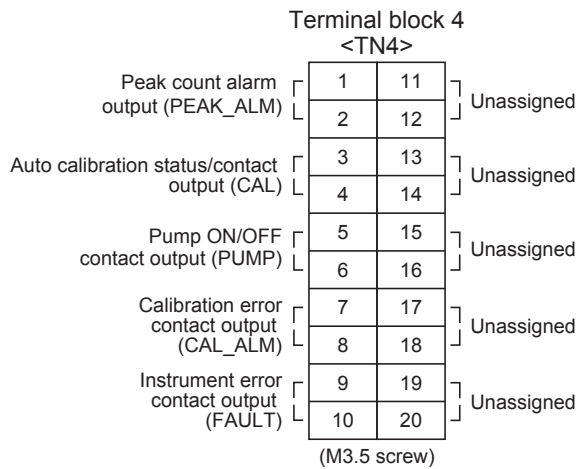

Terminal 4 <TN4>

- Between 1–2 : Peak count alarm contact output
It is conductive when peak count exceeds the setting time. It remains open below the setting time. For setting and operation, refer to “Section 6.6 Peak alarm setting”.
- Between 3–4 : Contact output of auto calibration status
When the auto calibration is carried out, it is conductive. Remains open otherwise.
- Between 5–6 : Pump ON/OFF contact output
Used when turning ON/OFF the pump. It is open during auto and manual calibration status and conductive during measurement.
- Between 7–8 : Calibration error contact output
It is open when an error occurs to the analyzer unit. It is normally conductive.
- Between 9–10 : It is open when an error occurs during zero calibration or span calibration. It is normally conductive.
- Between 11–20: For internal connection, wiring is not allowed. (Do not use it as junction terminal).

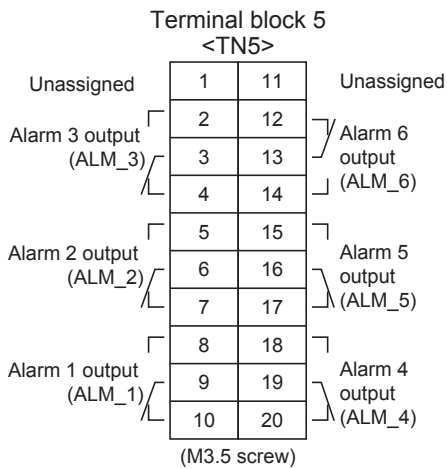

Terminal 5 <TN5>

Between 2, 3 and 4 : Alarm 3 output
When the output exceeds the set value, it is conductive between 2 and 3, and open between 3 and 4. Otherwise, it is open between 2 and 3 and conductive between 3 and 4.

Between 5, 6 and 7 : Alarm 2 output
When the output exceeds the set value, it is conductive between 5 and 6, and open between 6 and 7. Otherwise, it is open between 5 and 6, and conductive between 6 and 7.

Between 8, 9 and 10 : Alarm 1 output
When the output exceeds the set value, it is conductive between 8 and 9, and open between 9 and 10. Otherwise, it is open between 8 and 9.

Between 12, 13 and 14: Alarm 6 output
When the analyzer unit is turned ON, it is conductive between 12 and 13, and open between 13 and 14. When the analyzer unit is turned OFF, it is open between 12 and 13, and conductive between 13 and 14.

Between 15, 16 and 17: Alarm 5 output
When the output exceeds the set value, it is conductive between 15 and 16, and open between 16 and 17. Otherwise, it is open between 15 and 16, and conductive between 16 and 17.

Between 18, 19 and 20: Alarm 4 output
When the output exceeds the set value, it is conductive between 18 and 19, and open between 19 and 20. Otherwise, it is open between 18 and 19, and conductive between 19 and 20.
For detailed action of the alarm contact, refer to “Section 6.3 Alarm setting”.

Communication connector <CN2>

CAUTION

For avoiding electric shock and malfunctions, do not turn on the power supply until all wiring have been completed.

• Terminal allocation

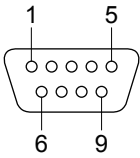
| Terminal number | Signal name | Pin connection |
|-----------------|---------------|---|
| 2 | Recive Data |  9-pin D-Sub (male) |
| 3 | Transmit Data | |
| 5 | Signal GND | |
| Others | NC | |

• Connection

CAUTION

Do not conduct Signal GND and Shield ground of cable (Analyzer main unit and I/O terminal module).

As connecting cable, use a commercially available RS-232 reverse cable.

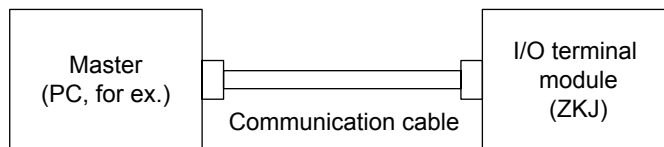

Connector to relay board <CN3>

Solenoid valve drive signal output for calibration

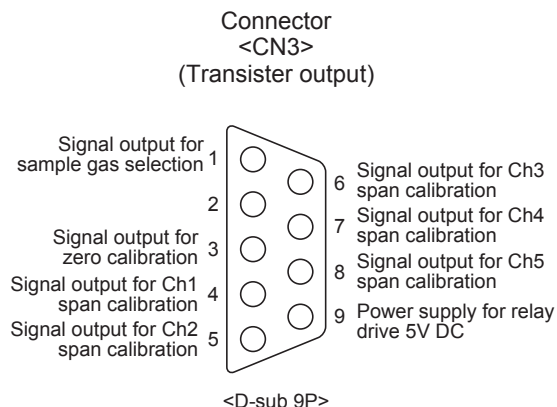

Connector <CN3> provides outputs in combination with calibration action during auto calibration and manual calibration.

An output is from a transistor (ratings: 5V/50mA).

A transistor is turned ON before starting each calibration.

Sample selection output is ON during measurement and OFF during calibration.

If calibration is not performed, the other transistors are OFF.

In case of auto calibration, sequential output is ON/OFF according to the setting.

Refer to “Section 3.5.2 (7) 2) In case of automatic calibration”.

**Note) No. 9 pin is for solenoid valve ON/OFF relay drive power (5V DC/0.5A, max).
Use No. 9 with reference to the diagram.**

Example of using solenoid valve drive signal output for calibration

<Electrical system>

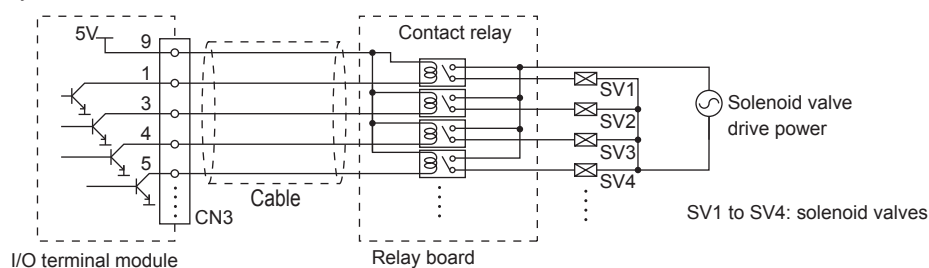

<Gas sampling system>

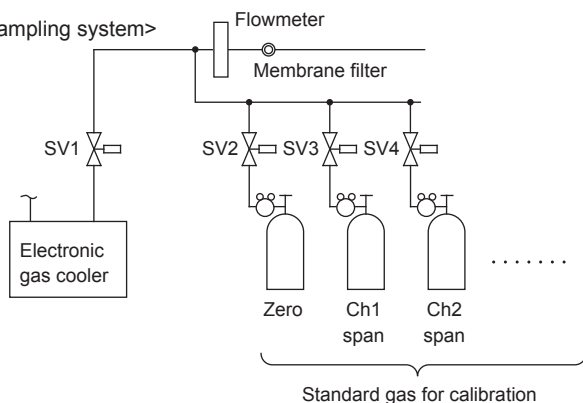

Refer to “Section 3.4.6 Example configuration of gas sampling system”.

Relay board and exclusive cable (D-sub 9p straight cable: 1.5 meters) are available on request.

(7) Timing of solenoid valve drive signal for calibration

1) Manual calibration (See “Section 6.9 Calibration”.)

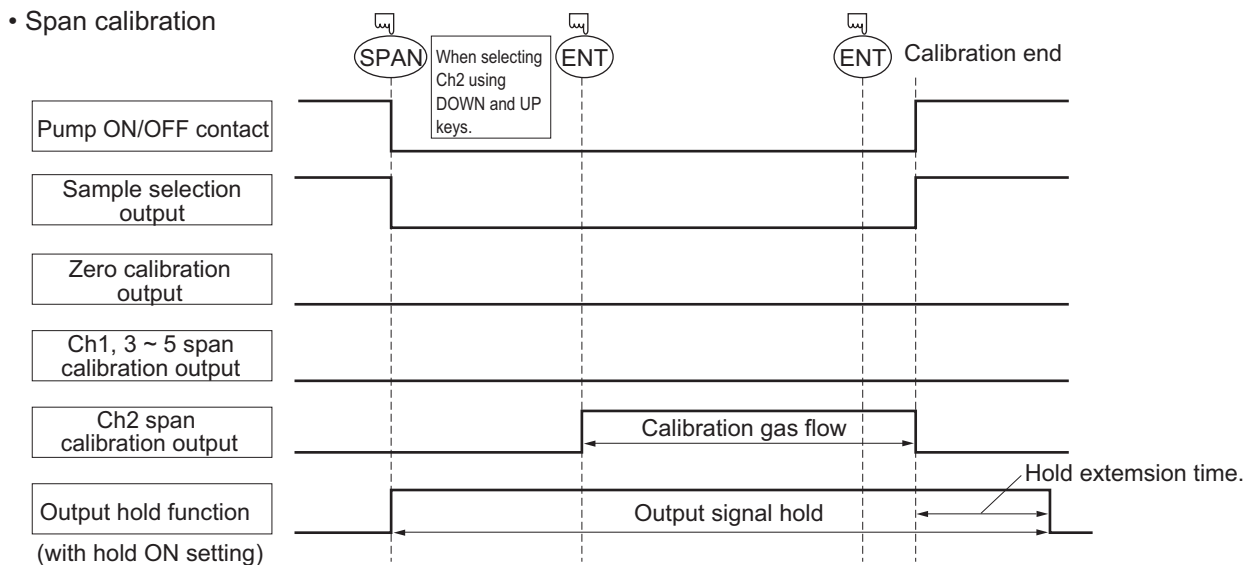
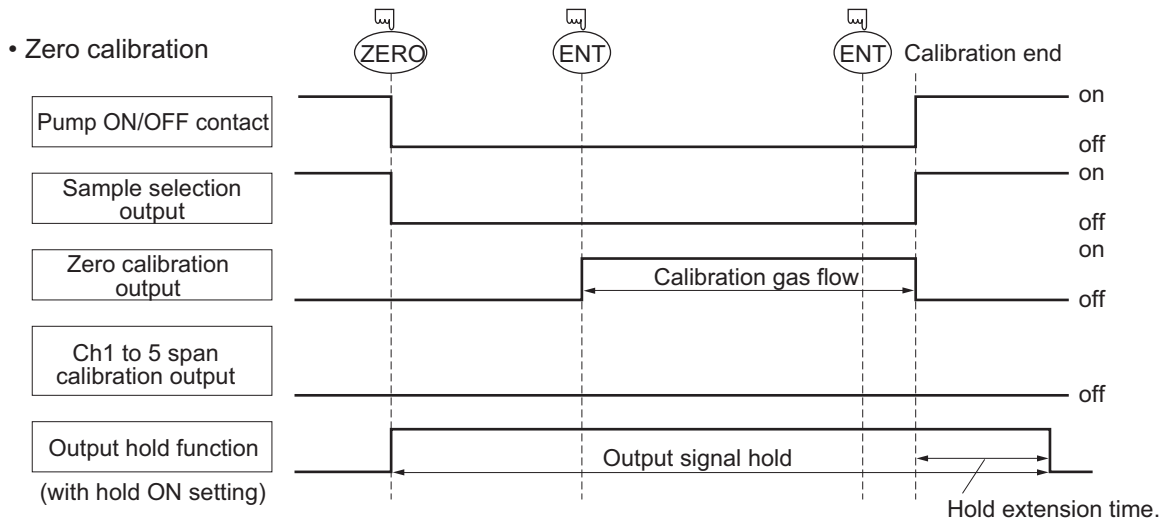

Note) The hold extension time depends on the gas flow time of the automatic calibration settings.

2) In case of automatic calibration (example shown in Section 6.4.1, Automatic calibration settings)

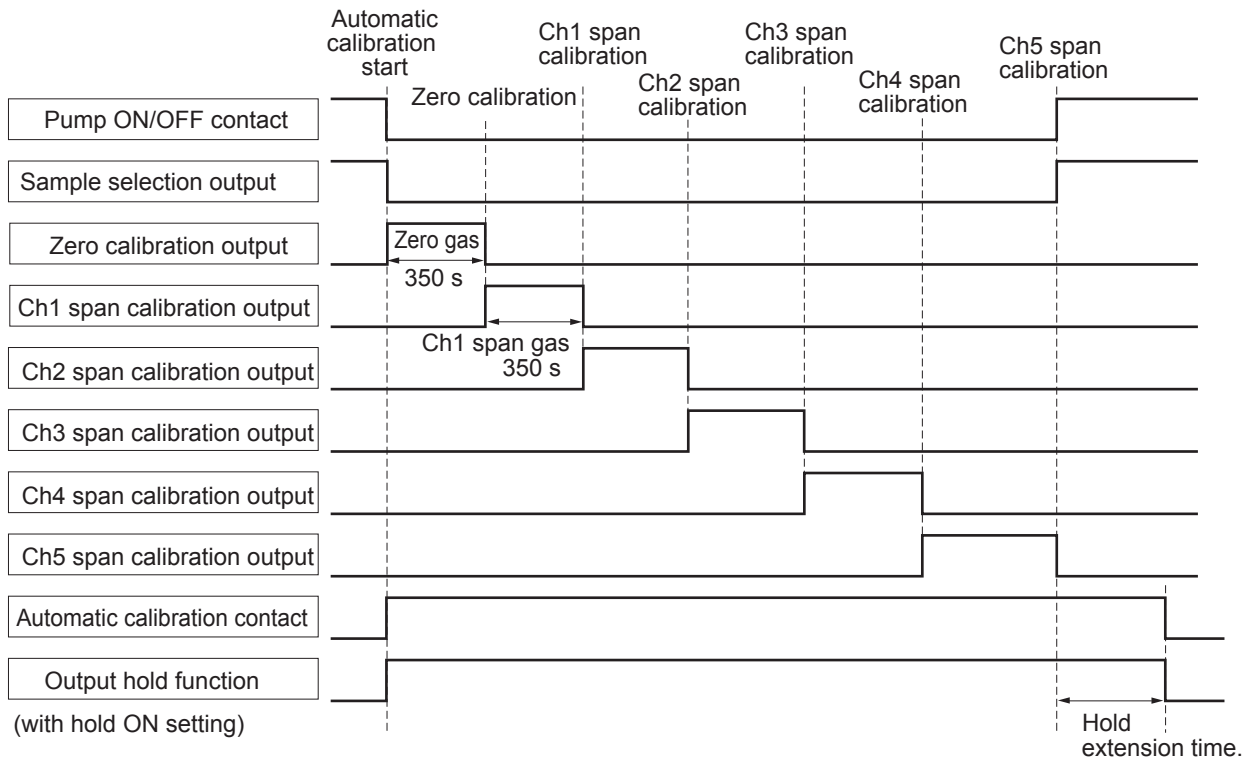

4. OPERATION

4.1 Preparation for operation

(1) Tube and wiring check

Double-check if tubes of the gas sampling and exhaust ports are correctly connected.
Double-check for proper wiring.

4.2 Warm-up operation and regular operation

(1) Operation procedure

- 1) Turn ON the power switch on the front panel of the analyzer unit.
The measurement screen appears on the front display panel in 1 or 2 seconds.
- 2) Wait for about 4 hours until the instrument is warmed up.
About 4 hours are required until the instrument allows accurate measurement.



CAUTION

When in warm-up, the concentration reading may be beyond.

upper limit of range or

lower limit of range.

But, it is not an error.

- 3) Setting of various set values
Perform the various settings according to “Section 6. Setting and Calibration”.
- 4) Zero calibration and span calibration
Perform zero calibration and span calibration after warm-up operation.
Refer to “Section 6.9. Calibration”.
- 5) Introduction and measurement of sampling gas
Introduce the sampling gas into the analyzer unit before starting measurement.

5. DESCRIPTION OF DISPLAY AND OPERATION PANELS

This section describes the display unit and operation panel of the analyzer main unit. It also explains the name and description of function on the operation panel.

5.1 Name and description of operation panel

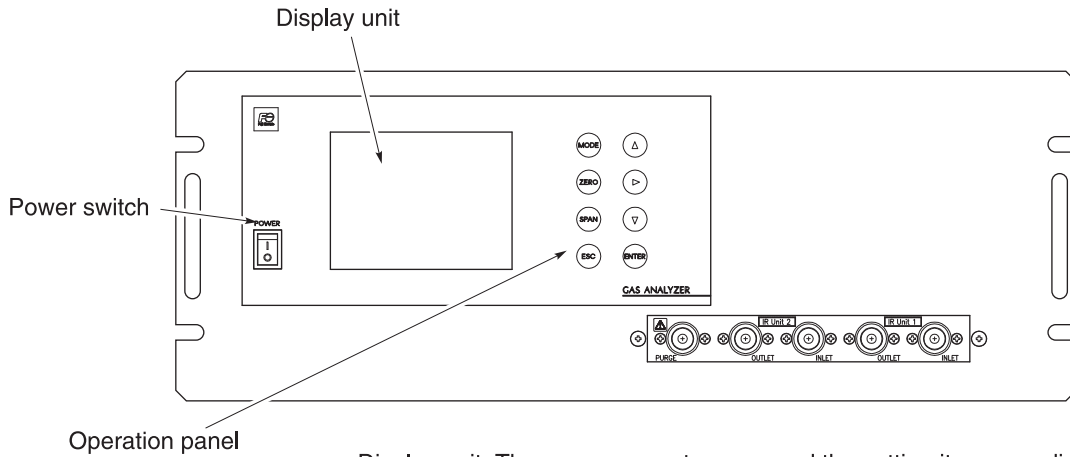

- Display unit: The measurement screen and the setting items are displayed.
- Operation panel: The configuration is as shown below.

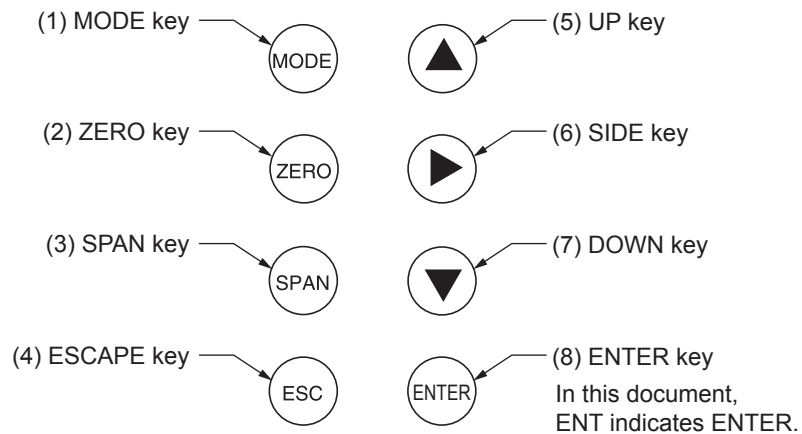

Fig. 5-1

| Name | Description | Name | Description |
|----------------|---|---------------|--|
| (1) MODE key | Used to switch the mode. | (5) UP key | Used to change the selected item (by moving the cursor) and to increase numeral value. |
| (2) ZERO key | Used for manual zero calibration. | (6) SIDE key | Used to change the selected item (by moving the cursor) and numeral digit. |
| (3) SPAN key | Used for manual span calibration. | (7) DOWN key | Used to change the selected item (by moving the cursor) and to decrease numeral value. |
| (4) ESCAPE key | Used to return to a previous screen or cancel the setting midway. | (8) ENTER key | Used for confirmation of selected items or values, and for execution of calibration. |

CAUTION

Push down on the key until the end.

5.2 Overview of display and operation panels

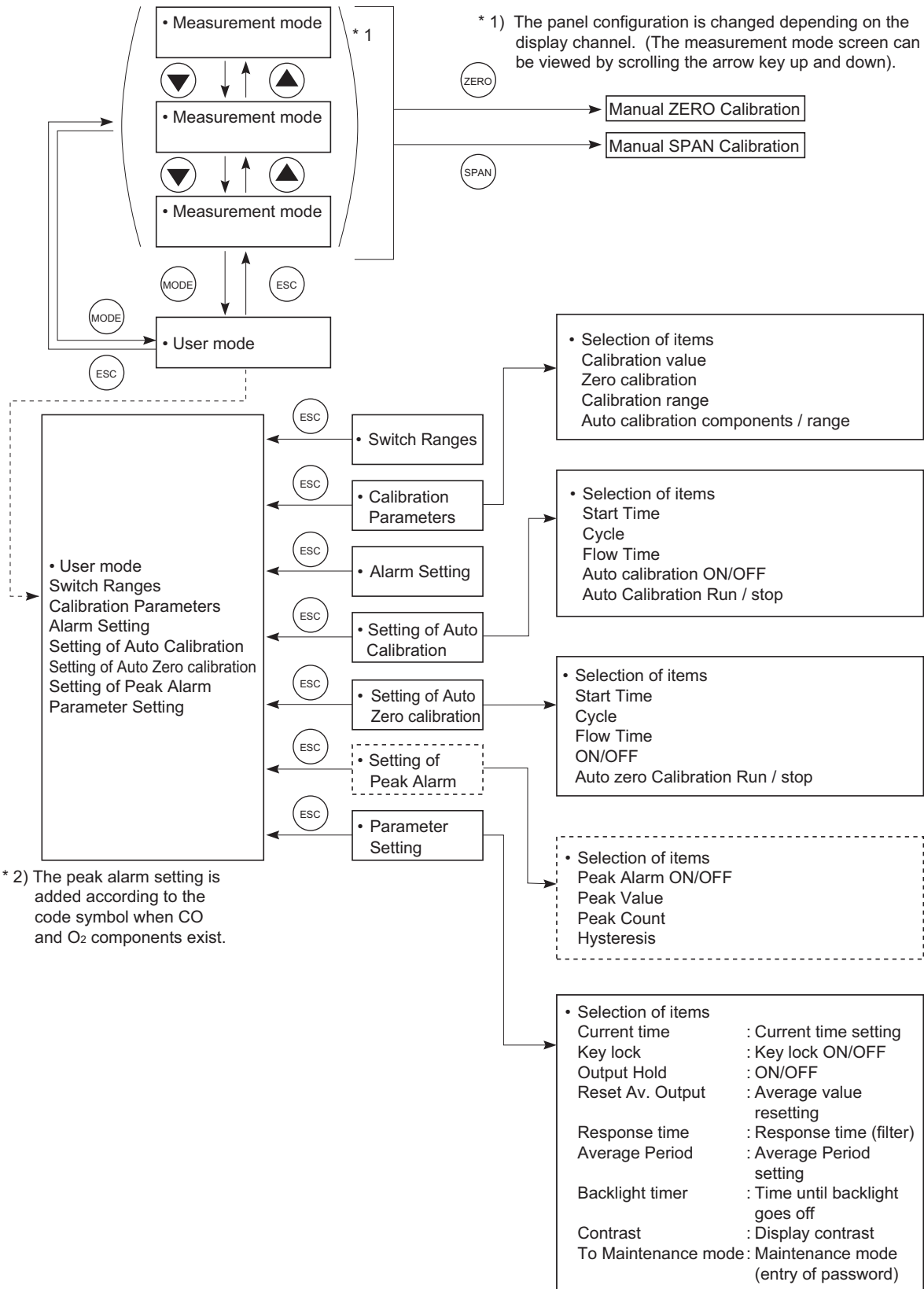

Fig. 5-2

5.3 Outline of display screen

(1) Measurement mode screen (appears when the power is turned ON)

The measurement screen depends on the number of components. The following screen configuration as shown as an example is for NO, SO₂, CO₂, CO and O₂ (output: 12 channel).

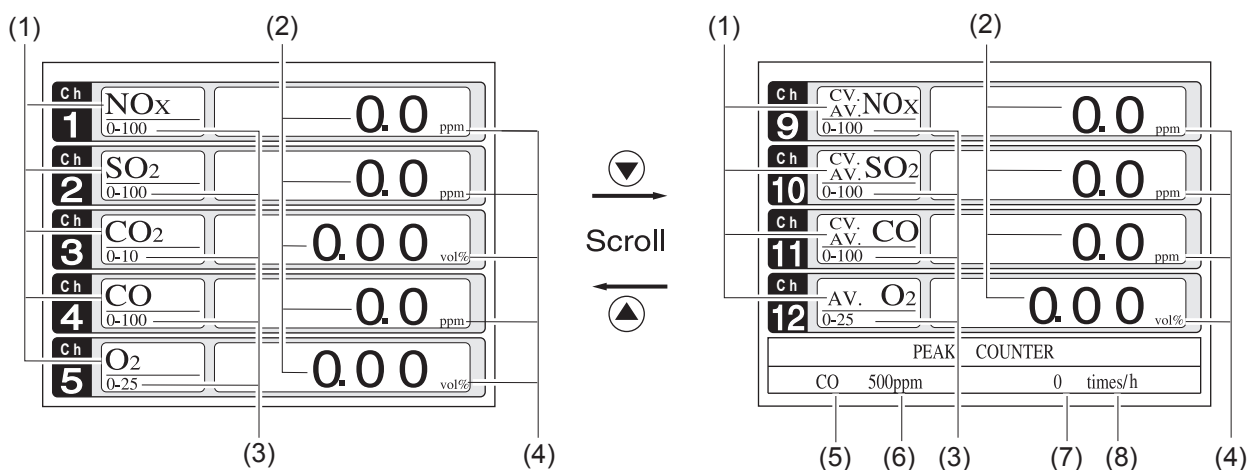

Fig. 5-3 Name and function of measurement mode screen

* For outputs of more than 5 channels, scroll the arrow key or to view.

| Name | Description | Name | Description |
|---------------------------|---|--------------------------------------|--|
| (1) Component display | Displays component of instantaneous value, converted instantaneous value, converted average value, etc. | (5) Peak alarm component display | Displays peak alarm component. |
| (2) Concentration display | Displays measured value of concentration. | (6) Peak alarm concentration display | Displays peak alarm concentration display. (Upper limit value) |
| (3) Range display | Displays measurement range values. | (7) Peak alarm times | Displays the alarm times exceeding the peak value. |
| (4) Unit display | Displays unit with ppm and vol%. | (8) Peak alarm unit display | Displays units of peak alarm with times/h. |

- **Instantaneous concentration value:**

The concentration display of Ch (component) where sampling components such as “CO₂”, “CO” or “O₂” are displayed in the component display, indicates current concentration values of the measured components contained in gas that is now under measurement.

- **O₂ conversion concentration values:**

Ch components where “cv**” is displayed as “cv CO” in the component display are calculated from the following equation, by setting sampling components, O₂ instantaneous/concentration values and O₂ conversion reference value (see Section 6.8).

$$\text{Conversion output} = \frac{21 - O_n}{21 - O_s} \times C_s$$

O_n: The value of the O₂ conversion reference value
(Value set by application)

O_s: Instantaneous concentration of oxygen (%)
(You can set the O_s higher limit at Limit menu in the maintenance mode.)

C_s: Concentration of relevant measured component.

The converted sampling components are NO_x, SO₂ and CO only.

- **O₂ conversion concentration average value:**

In the Ch (component) and O₂ average value where “^{CV}_{AV} **” is displayed as “^{CV}_{AV} CO” in the component display, a value obtained by averaging O₂ conversion concentration value or O₂ average value in a fixed time is output every 30 seconds.

Averaging time can be changed between 1 minute and 59 minutes or 1 hour and 4 hours according to the average time settings (See 6.7, Parameter setting).

(The set time is displayed as “1h”, for instance, in the range display.)

* The measurement ranges of O₂ conversion concentration value and O₂ conversion concentration average value are the same as that of the measuring components. Also, the measurement range of O₂ average value is the same as that of O₂.

(2) Setting/selection screen

The setting/selection screen is configured as Fig. 5-4:

- In the status display area, the current status is displayed.
- In the message display area, messages associated with operation are displayed.
- In the setting item and selection item display area, items or values to be set are displayed, as required. To work on the area, move the cursor to any item by using UP, DOWN and SIDE keys.

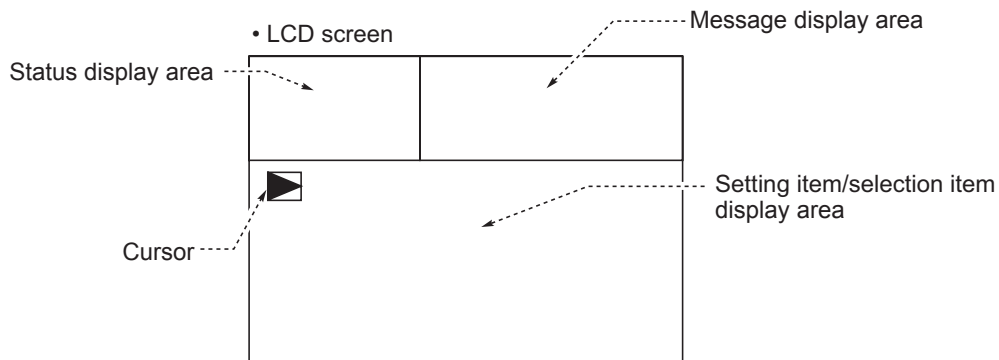

Fig. 5-4

(3) Contents of measured channel (Ch)

The following table gives measurement channels and their contents according to the symbols.

| Code symbol | | | Contents |
|-------------|-----------|------------|--|
| 5th digit | 6th digit | 22nd digit | |
| P | Y | Y | Ch1: NO |
| A | Y | Y | Ch1: SO ₂ |
| D | Y | Y | Ch1: CO ₂ |
| B | Y | Y | Ch1: CO |
| E | Y | Y | Ch1: CH ₄ |
| F | Y | Y | Ch1: NO, Ch2: SO ₂ |
| H | Y | Y | Ch1: NO, Ch2: CO |
| G | Y | Y | Ch1: CO ₂ , Ch2: CO |
| L | Y | Y | Ch1: NO, Ch2: SO ₂ , Ch3: CO |
| M | Y | Y | Ch1: NO, Ch2: SO ₂ , Ch3: CO ₂ , Ch4: CO |
| P | A, B, C | A | Ch1: NO _x , Ch2: O ₂ , Ch3: Converted NO _x , Ch4: Converted NO _x average, Ch5: O ₂ average |
| A | A, B, C | A | Ch1: SO ₂ , Ch2: O ₂ , Ch3: Converted SO ₂ , Ch4: Converted SO ₂ average, Ch5: O ₂ average |
| B | A, B, C | A | Ch1: CO, Ch2: O ₂ , Ch3: Converted CO, Ch4: Converted CO average, Ch5: O ₂ average |
| F | A, B, C | A | Ch1: NO _x , Ch2: SO ₂ , Ch3: O ₂ , Ch4: Converted NO _x , Ch5: Converted SO ₂ , Ch6: Converted NO _x average, Ch7: Converted SO ₂ average, Ch8: O ₂ average |
| H | A, B, C | A | Ch1: NO _x , Ch2: CO, Ch3: O ₂ , Ch4: Converted NO _x , Ch5: Converted CO, Ch6: Converted NO _x average, Ch7: Converted CO average, Ch8: O ₂ average |
| G | A, B, C | A | Ch1: CO ₂ , Ch2: CO, Ch3: O ₂ , Ch4: Converted CO, Ch5: Converted CO average, Ch6: O ₂ average |
| L | A, B, C | A | Ch1: NO _x , Ch2: SO ₂ , Ch3: CO, Ch4: O ₂ , Ch5: Converted NO _x , Ch6: Converted SO ₂ , Ch7: Converted CO, Ch8: Converted NO _x average, Ch9: Converted SO ₂ average, Ch10: Converted CO average, Ch11: O ₂ average |
| M | A, B, C | A | Ch1: NO _x , Ch2: SO ₂ , Ch3: CO ₂ , Ch4: CO, Ch5: O ₂ , Ch6: Converted NO _x , Ch7: Converted SO ₂ , Ch8: Converted CO, Ch9: Converted NO _x average, Ch10: Converted SO ₂ average, Ch11: Converted CO average, Ch12: O ₂ average |
| B | A, B, C | B | Ch1: CO, Ch2: O ₂ |
| H | A, B, C | B | Ch1: NO, Ch2: CO, Ch3: O ₂ |
| G | A, B, C | B | Ch1: CO ₂ , Ch2: CO, Ch3: O ₂ |
| L | A, B, C | B | Ch1: NO, Ch2: SO ₂ , Ch3: CO, Ch4: O ₂ |
| M | A, B, C | B | Ch1: NO, Ch2: SO ₂ , Ch3: CO ₂ , Ch4: CO, Ch5: O ₂ |
| B | A, B, C | C | Ch1: CO, Ch2: O ₂ , Ch3: Converted CO, Ch4: Converted CO average, Ch5: O ₂ average |
| H | A, B, C | C | Ch1: NO _x , Ch2: CO, Ch3: O ₂ , Ch4: Converted NO _x , Ch5: Converted CO, Ch6: Converted NO _x average, Ch7: Converted CO average, Ch8: O ₂ average |
| G | A, B, C | C | Ch1: CO ₂ , Ch2: CO, Ch3: O ₂ , Ch4: Converted CO, Ch5: Converted CO average, Ch6: O ₂ average |
| L | A, B, C | C | Ch1: NO _x , Ch2: SO ₂ , Ch3: CO, Ch4: O ₂ , Ch5: Converted NO _x , Ch6: Converted SO ₂ , Ch7: Converted CO, Ch8: Converted NO _x average, Ch9: Converted SO ₂ average, Ch10: Converted CO average, Ch11: O ₂ average |
| M | A, B, C | C | Ch1: NO _x , Ch2: SO ₂ , Ch3: CO ₂ , Ch4: CO, Ch5: O ₂ , Ch6: Converted NO _x , Ch7: Converted SO ₂ , Ch8: Converted CO, Ch9: Converted NO _x average, Ch10: Converted SO ₂ average, Ch11: Converted CO average, Ch12: O ₂ average |
| Q | Y | Y | Ch1:N ₂ O |
| R | Y | Y | Ch1:N ₂ O, Ch2:CO ₂ |
| S | Y | Y | Ch1:NO, Ch2:N ₂ O, Ch3:CO ₂ |
| T | Y | Y | Ch1:SO ₂ , Ch2:N ₂ O, Ch3:CO ₂ |
| U | Y | Y | Ch1:N ₂ O, Ch2:CO ₂ , Ch3:CO |
| V | Y | Y | Ch1:CH ₄ , Ch2:N ₂ O, Ch3:CO ₂ |
| W | Y | Y | Ch1:NO, Ch2:SO ₂ , Ch3:N ₂ O, Ch4:CO ₂ |
| S | A, B, C | Y | Ch1:NO, Ch2:N ₂ O, Ch3:CO ₂ , Ch4:O ₂ |
| T | A, B, C | Y | Ch1:SO ₂ , Ch2:N ₂ O, Ch3:CO ₂ , Ch4:O ₂ |
| U | A, B, C | Y, B | Ch1:N ₂ O, Ch2:CO ₂ , Ch3:CO, Ch4:O ₂ |
| V | A, B, C | Y | Ch1:CH ₄ , Ch2:N ₂ O, Ch3:CO ₂ , Ch4:O ₂ |
| W | A, B, C | Y | Ch1:NO, Ch2:SO ₂ , Ch3:N ₂ O, Ch4:CO ₂ , Ch5:O ₂ |
| S | A, B, C | A | Ch1:NO _x , Ch2:N ₂ O, Ch3:CO ₂ , Ch4:O ₂ , Ch5:Converted NO _x , Ch6:Converted NO _x average, Ch7:O ₂ average |
| T | A, B, C | A | Ch1:SO ₂ , Ch2:N ₂ O, Ch3:CO ₂ , Ch4:O ₂ , Ch5:Converted SO ₂ , Ch6:Converted SO ₂ average, Ch7:O ₂ average |
| U | A, B, C | A, C | Ch1:N ₂ O, Ch2:CO ₂ , Ch3:CO, Ch4:O ₂ , Ch5:Converted CO, Ch6:Converted CO average, Ch7:O ₂ average |
| V | A, B, C | A | Ch1:CH ₄ , Ch2:N ₂ O, Ch3:CO ₂ , Ch4:O ₂ , Ch5:O ₂ average |
| W | A, B, C | A | Ch1:NO _x , Ch2:SO ₂ , Ch3:N ₂ O, Ch4:CO ₂ , Ch5:O ₂ , Ch6:Converted NO _x , Ch7:Converted SO ₂ , Ch8:Converted NO _x average, Ch9:Converted SO ₂ average, Ch10:O ₂ average |

Note

Note: When the 22nd digit code is A or C, the component of the NO analyzer is displayed as NO_x.

5.4 Basic operation

• Measurement mode

The measurement mode can be displayed up to 5 channels in a single screen. If 5 channels or more are to be displayed in a single screen, press the or key to scroll the channel one by one.

| | | |
|------|--------------------------|-----------|
| Ch 1 | NOx 0-100 | 0.0 ppm |
| Ch 2 | SO ₂ 0-100 | 0.0 ppm |
| Ch 3 | CO ₂ 0-10 | 0.00 vol% |
| Ch 4 | CO 0-100 | 0.0 ppm |
| Ch 5 | O ₂ 0-25 | 0.00 vol% |



| | | |
|------|------------------------------|-----------|
| Ch 5 | O ₂ 0-25 | 0.00 vol% |
| Ch 6 | CV. NOx 0-100 | 0.0 ppm |
| Ch 7 | CV. SO ₂ 0-100 | 0.00 vol% |
| Ch 8 | CV. CO 0-100 | 0.0 ppm |
| Ch 9 | CV. AV. NOx 0-100 | 0.0 ppm |



| | | |
|--------------|----------------------------------|-----------|
| Ch 9 | CV. AV. NOx 0-100 | 0.0 ppm |
| Ch 10 | CV. AV. SO ₂ 0-100 | 0.0 ppm |
| Ch 11 | CV. AV. CO 0-100 | 0.0 ppm |
| Ch 12 | AV. O ₂ 0-25 | 0.00 vol% |
| PEAK COUNTER | | |
| CO | 500ppm | 0 times/H |

ZERO

⇒ Manual Zero calibration
See 6.9.1.

⇒ Manual Span calibration
See 6.9.2.

SPAN

ESC

MODE

• User mode displays;

- Switch Ranges
- Calibration Parameters
- Alarm Setting
- Setting of Auto Calibration
- Setting of Auto Zero Calibration
- Setting of Peak Alarm
- Parameter Setting.

For the setting contents, refer to “Chapter 6. Setting and calibration”.

| | |
|---|--|
| User Mode | Select an item with UP/DOWN and ENT Back with ESC |
| <ul style="list-style-type: none"> ▶ Switch Ranges Calibration Parameters Alarm Setting Setting of Auto Calibration Setting of Auto Zero Calibration Setting of Peak Alarm Parameter Setting | |



Measurement Mode

6. SETTING AND CALIBRATION

6.1 Switch of range

6.1.1 Setting of range switch mode

Set the range switch mode as follows.

- (1) Press the **(MODE)** key in measurement mode to display the User mode screen.
- (2) Move the cursor to “Switch Ranges” and press the **(ENT)** key.

- (3) The “Channel Selection” screen appears. Move the **(▶)** cursor by pressing the **(▲)** or the **(▼)** key on the channel selection screen that appears, and select Ch (component).

- (4) Then press the **(ENT)** key.

- (5) Selected range switch mode is highlighted.

Press the **(▲)** or the **(▼)** key to select a desired switch mode.

Description of setting

MR: Select a desired range on this screen.
 RR: Select a desired range according to the remote range switch contact input.
 AR: Automatically switched from Range 1 to Range 2 when the measured concentration exceeds 90% of Range 1. Automatically switched from Range 2 to Range 1 when the measured concentration becomes smaller than 80% of Range 1.

* Operation set for each Ch only can be performed.

- (6) Then press the **(ENT)** key to confirm the selection.
 If “MR” is selected, the cursor moves to “Range Switch.”

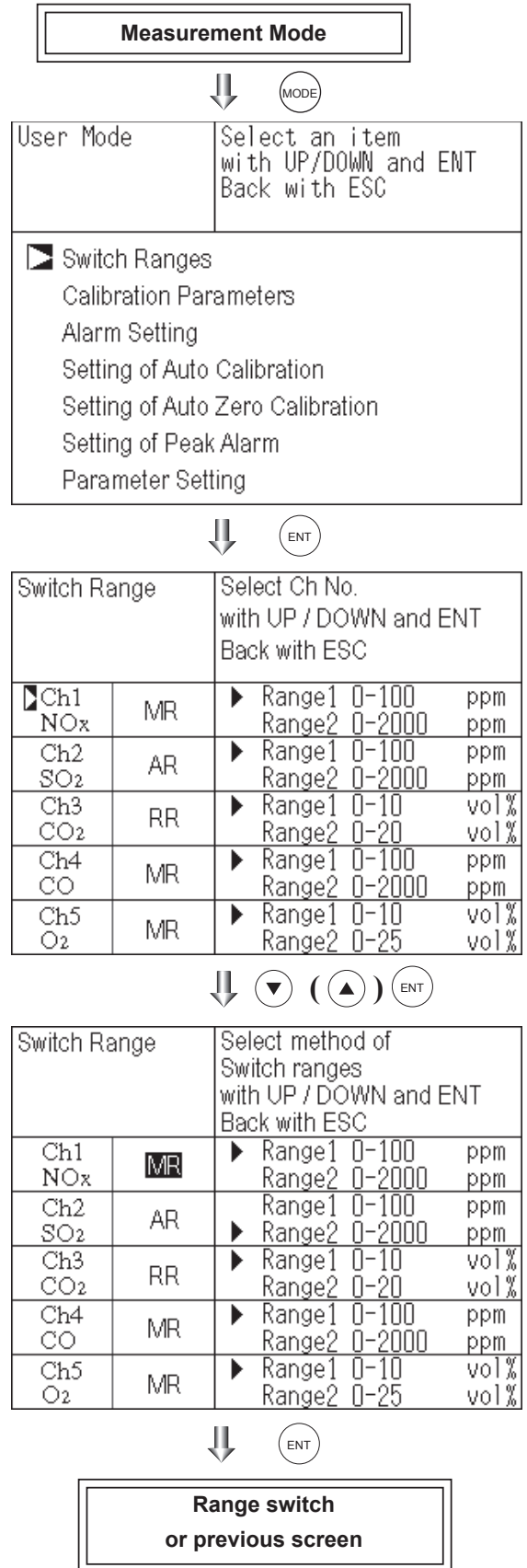





6.1.2 Manual range switch

The range of the measured component can be switched manually as follows.

- (1) Select "MR" as range switch mode, and then press the  key.

| Switch Range | | Select method of Switch ranges with UP / DOWN and ENT Back with ESC |
|------------------------|---|---|
| Ch1 NO _x |  | ▶ Range1 0-100 ppm Range2 0-2000 ppm |
| Ch2 SO ₂ | AR | ▶ Range1 0-100 ppm Range2 0-2000 ppm |
| Ch3 CO ₂ | RR | ▶ Range1 0-10 vol % Range2 0-20 vol % |
| Ch4 CO | MR | ▶ Range1 0-100 ppm Range2 0-2000 ppm |
| Ch5 O ₂ | MR | ▶ Range1 0-10 vol % Range2 0-25 vol % |



- (2) Move the cursor to range selection, and then select a desired range by pressing the  or the  key. (The  mark indicates the currently selected range.)
- (3) Then press the  key, and the measurement is carried out in the selected range.

| Switch Range | | Select range with UP/DOWN and ENT Back with ESC |
|------------------------|----|---|
| Ch1 NO _x | MR | ▣ Range1 0-100 ppm Range2 0-2000 ppm |
| Ch2 SO ₂ | AR | ▶ Range1 0-100 ppm Range2 0-2000 ppm |
| Ch3 CO ₂ | RR | ▶ Range1 0-10 vol % Range2 0-20 vol % |
| Ch4 CO | MR | ▶ Range1 0-100 ppm Range2 0-2000 ppm |
| Ch5 O ₂ | MR | ▶ Range1 0-10 vol % Range2 0-25 vol % |



End of Range Switch

Note) If "RR" or "AR" is selected as range switch mode, this operation cannot be performed.

The range for O₂ conversion value, O₂ conversion average value, and O₂ average value is automatically switched if corresponding instantaneous value range is switched.

To close the setting

Press the  key to end the setting of range switch mode or range switch operation or stop the operation in the middle, and the setting operation is made invalid and the previous screen appears.

Range identification contact operation

The range identification contact output corresponding to each Ch (component) is conductive when Range 1 is selected, and open when Range 2 is selected, which is applicable to any of the range switch mode selected.

Note that even if the range is switched during the hold of measurement value by remote hold contact input or the hold of measurement value at the time of calibration, the range identification contact output maintains the contact state immediately before the hold. After stop of the hold, the contact state of the current range is resumed.



6.2 Calibration setting



This mode is used to set calibration concentration and actions. The calibration setting involves calibration concentration, zero calibration, calibration range and auto calibration component/range.



6.2.1 Setting of calibration concentration

It allows you to set concentrations of the standard gas (zero and span) of each channel used for calibration.

(1) During measurement, press the  key to display the User mode.

(2) Point the cursor to “Calibration Parameters” by pressing the  or  key. Press the  key.

(3) In the “Calibration Parameters” screen that appears, point the cursor to “Calibration Value” by pressing the  or  key. Press the  key.

(4) In the “Calibration Concentration Ch Selection” screen that appears, point the cursor to Ch you want to set by using the  or  key. Press the  key.

Measurement Mode



| | |
|---|--|
| User Mode | Select an item with UP/DOWN and ENT Back with ESC |
| Switch Ranges <input checked="" type="checkbox"/> Calibration Parameters Alarm Setting Setting of Auto Calibration Setting of Auto Zero Calibration Setting of Peak Alarm Parameter Setting | |



| | |
|---|--|
| Cal. Parameters | Select an item with UP/DOWN and ENT Back with ESC |
| <input checked="" type="checkbox"/> Calibration Value About ZERO Calibration About Calibration Range Auto Calibration Components / Range | |



| Cal. Settings | Select Ch No. for setting calibration value | | |
|---|---|---------|--------|
| Cal. Value | | | |
| Ch | RANGE | ZERO | SPAN |
| <input checked="" type="checkbox"/> Ch1 | 0-100ppm | +0000.0 | 0100.0 |
| NOx | 0-2000ppm | +00000 | 02000 |
| Ch2 | 0-100ppm | +0000.0 | 0100.0 |
| SO2 | 0-2000ppm | +00000 | 02000 |
| Ch3 | 0-10vol% | +000.00 | 010.00 |
| CO2 | 0-20vol% | +000.00 | 020.00 |
| Ch4 | 0-100ppm | +0000.0 | 0100.0 |
| CO | 0-2000ppm | +00000 | 02000 |
| Ch5 | 0-10vol% | 21.00 | 01.00 |
| O2 | 0-25vol% | 21.00 | 01.00 |



- (5) In the “Calibration Concentration Selection” screen that appears, select any concentration item (zero, span) you want to set by pressing the \blacktriangle , \blacktriangledown , \blacktriangleright key.

Then press the ENT key, and the selected value is highlighted.

| Cal. Settings | | Select setting value | |
|-----------------|-----------|----------------------|--------|
| Cal. Value | | | |
| Ch | RANGE | ZERO | SPAN |
| Ch1 | 0-100ppm | +0000.0 | 0100.0 |
| NO _x | 0-2000ppm | +00000 | 02000 |
| Ch2 | 0-100ppm | +0000.0 | 0100.0 |
| SO ₂ | 0-2000ppm | +00000 | 02000 |
| Ch3 | 0-10vol% | +000.00 | 010.00 |
| CO ₂ | 0-20vol% | +000.00 | 020.00 |
| Ch4 | 0-100ppm | +0000.0 | 0100.0 |
| CO | 0-2000ppm | +00000 | 02000 |
| Ch5 | 0-10vol% | 21.00 | 01.00 |
| O ₂ | 0-25vol% | 21.00 | 01.00 |



- (6) In the “Calibration Concentration Value Setting” screen that appears, enter calibration gas concentration values (zero and span). For value entry, press the \blacktriangle or \blacktriangledown key, and a 1-digit value increases or decreases. By pressing the \blacktriangleright , the digit moves. After setting, save the entry by pressing the ENT key. The saved value becomes valid from the next calibration process.

Note) Enter settings that correspond to each range. If zirconia type is used as O₂ sensor, select 21.00 for the field of Zero (when air is used), and select the concentration listed on the cylinder if the air contained in a cylinder is used.

Cursor for setting value

| Cal. Settings | | Set calibration value | |
|-----------------|-----------|-----------------------|--------|
| Cal. Value | | | |
| Ch | RANGE | ZERO | SPAN |
| Ch1 | 0-100ppm | +0000.0 | 0100.0 |
| NO _x | 0-2000ppm | +00000 | 02000 |
| Ch2 | 0-100ppm | +0000.0 | 0100.0 |
| SO ₂ | 0-2000ppm | +00000 | 02000 |
| Ch3 | 0-10vol% | +000.00 | 010.00 |
| CO ₂ | 0-20vol% | +000.00 | 020.00 |
| Ch4 | 0-100ppm | +0000.0 | 0100.0 |
| CO | 0-2000ppm | +00000 | 02000 |
| Ch5 | 0-10vol% | 21.00 | 01.00 |
| O ₂ | 0-25vol% | 21.00 | 01.00 |



**End of Calibration
Concentration Setting**

To close the setting

To close the calibration concentration value setting process or cancel this mode midway, press the ESC key. A previous screen will return.

Setting range of values

NO_x, SO₂, CO₂, CO, CH₄, N₂O external O₂ measurement and built-in paramagnetic O₂ sensor

Span gas: 1 to 105% of full scale (Full scale (FS) is the same as each range value.)





External Zirconia O₂ measurement

Zero gas: 5 to 25 vol%
Span gas: 0.01 to 5 vol%

The setting cannot be performed beyond the range.

6.2.2 Setting of manual zero calibration

When zero calibration is made manually, set either all measurement components should be calibrated simultaneously or each component should be calibrated while selecting one by one.



- (1) During measurement, press the  key to display the User mode.
- (2) Point the cursor to “Calibration Parameters” by pressing the  or  key. Press the  key.

Measurement Mode





| | |
|--|--|
| User Mode | Select an item with UP/DOWN and ENT Back with ESC |
| <p style="text-align: center;">Switch Ranges</p> <p><input checked="" type="checkbox"/> Calibration Parameters</p> <p style="text-align: center;">Alarm Setting</p> <p style="text-align: center;">Setting of Auto Calibration</p> <p style="text-align: center;">Setting of Auto Zero Calibration</p> <p style="text-align: center;">Setting of Peak Alarm</p> <p style="text-align: center;">Parameter Setting</p> | |



- (3) In the “Calibration Parameters” screen that appears, point the cursor to “About ZERO Calibration” by pressing the  or  key. Press the  key.

| | |
|--|--|
| Cal. Parameters | Select an item with UP/DOWN and ENT Back with ESC |
| <p style="text-align: center;">Calibration Value</p> <p><input checked="" type="checkbox"/> About ZERO Calibration</p> <p style="text-align: center;">About Calibration Range</p> <p style="text-align: center;">Auto Calibration Components / Range</p> | |



- (4) In the “Manual ZERO Calibration Ch Selection” screen that appears, point the cursor to Ch (component) you want to set by using the  or  key. Press the  key.

| | | | |
|--|------------------|-------------------|---------|
| Cal. Settings ZERO Cal. | Select Ch No. | | |
| <input checked="" type="checkbox"/> Ch1 NO _x | Range1 0-100 ppm | Range2 0-2000 ppm | at once |
| Ch2 SO ₂ | Range1 0-100 ppm | Range2 0-2000 ppm | at once |
| Ch3 CO ₂ | Range1 0-10 vol% | Range2 0-20 vol% | at once |
| Ch4 CO | Range1 0-100 ppm | Range2 0-2000 ppm | at once |
| Ch5 O ₂ | Range1 0-10 vol% | Range2 0-25 vol% | each |



(5) In the “Manual ZERO Calibration Selection” screen that appears, select “at once” or “each” by pressing the \blacktriangle or \blacktriangledown key. When selecting “at once”, the Ch (components) to be set can be zero-calibrated at the same time. When selecting “each”, either of the Ch (components) to be selected is zero-calibrated. After setting, press the ENT key.

| Cal. Settings ZERO Cal. | | Set each or both Ch at ZERO Calibration | |
|-------------------------|---------------------------------------|---|----------------|
| Ch1 NO _x | Range1 0-100 ppm Range2 0-2000 ppm | | at once |
| Ch2 SO ₂ | Range1 0-100 ppm Range2 0-2000 ppm | | at once |
| Ch3 CO ₂ | Range1 0-10 vol% Range2 0-20 vol% | | at once |
| Ch4 CO | Range1 0-100 ppm Range2 0-2000 ppm | | at once |
| Ch5 O ₂ | Range1 0-10 vol% Range2 0-25 vol% | | each |



**End of
Manual Zero Calibration Setting**

To close the setting

To close the manual zero calibration setting or to cancel this mode midway, press the ESC key. A previous screen will return.

Example

Whether “each” or “at once” can be determined for each Ch (component).

•Setting “each”

Select the Ch (component) on the manual zero calibration screen and then perform zero calibration.

•Setting “at once”

At a manual zero calibration, zero of Ch (components) for which “at once” was selected can simultaneously be calibrated.

*** When the cylinder air or atmospheric air is used for the zero gas, select “At once.”**

Manual Calibration screen

• When setting all components to “each”:

| ZERO Cal. | ENT : Go on Calibration of selected Ch ESC : Not calibration | |
|------------------------|---|---------|
| Ch1 NO _x | ▶Range1 0-100 ppm ▶Range2 0-2000 ppm | ▢ -2.1 |
| Ch2 SO ₂ | ▶Range1 0-100 ppm ▶Range2 0-2000 ppm | ▢ -0.5 |
| Ch3 CO ₂ | ▶Range1 0-10 vol% ▶Range2 0-20 vol% | ▢ 0.00 |
| Ch4 CO | ▶Range1 0-100 ppm ▶Range2 0-2000 ppm | ▢ 0.0 |
| Ch5 O ₂ | ▶Range1 0-10 vol% ▶Range2 0-25 vol% | ▢ 21.00 |

A single cursor will appear.





• When setting all components to “at once”:

| ZERO Cal. | ENT : Go on Calibration of selected Ch ESC : Not calibration | |
|------------------------|---|---------|
| Ch1 NO _x | ▶Range1 0-100 ppm ▶Range2 0-2000 ppm | ▢ 0.0 |
| Ch2 SO ₂ | ▶Range1 0-100 ppm ▶Range2 0-2000 ppm | ▢ 0.3 |
| Ch3 CO ₂ | ▶Range1 0-10 vol% ▶Range2 0-20 vol% | ▢ 0.00 |
| Ch4 CO | ▶Range1 0-100 ppm ▶Range2 0-2000 ppm | ▢ -0.1 |
| Ch5 O ₂ | ▶Range1 0-10 vol% ▶Range2 0-25 vol% | ▢ 21.00 |

Cursors will appear at all components where “at once” is set.

6.2.3 Setting of calibration range

This mode is used to set if the range of each Ch (component) at the zero or span calibration (manual calibration or auto calibration) should be calibrated with a single range or 2 ranges.



- (1) During measurement, press the  key to display the User mode.
- (2) Point the cursor to “Calibration Parameters” by pressing the  or  key. Press the  key.

Measurement Mode





| | |
|---|--|
| User Mode | Select an item with UP/DOWN and ENT Back with ESC |
| Switch Ranges <input checked="" type="checkbox"/> Calibration Parameters Alarm Setting Setting of Auto Calibration Setting of Auto Zero Calibration Setting of Peak Alarm Parameter Setting | |



- (3) In the “Calibration Parameters” screen that appears, point the cursor to “About Calibration Range” by pressing the  or  key. Press the  key.

| | |
|---|--|
| Cal. Parameters | Select an item with UP/DOWN and ENT Back with ESC |
| Calibration Valve About ZERO Calibration <input checked="" type="checkbox"/> About Calibration Range Auto Calibration Components / Range | |



- (4) In the “Calibration Range Ch Selection” screen that appears, point the cursor to the Ch you want to set by pressing the  or  key. Press the  key.

| | | | |
|--|---------------------------------------|--|---------|
| Cal. Settings Cal. Range | Select Ch No. | | |
| <input checked="" type="checkbox"/> Ch1 NO _x | Range1 0-100 ppm Range2 0-2000 ppm | | both |
| Ch2 SO ₂ | Range1 0-100 ppm Range2 0-2000 ppm | | current |
| Ch3 CO ₂ | Range1 0-10 vol% Range2 0-20 vol% | | current |
| Ch4 CO | Range1 0-100 ppm Range2 0-2000 ppm | | both |
| Ch5 O ₂ | Range1 0-10 vol% Range2 0-25 vol% | | current |



(5) On the “calibration range selection” screen that appears, select “both” or “current” by pressing the \blacktriangle or the \blacktriangledown key.

- If “both” is selected, zero or span calibration is performed with Range 1 and Range 2 of the selected Ch interlocked.
- If “current” is selected, zero or span calibration is performed only for the range displayed when calibration of selected Ch is performed.

Press the ENT key after the selection, and the specified calibration is performed.

| Cal. Settings | | Set calibration range | |
|------------------------|---------------------------------------|-----------------------|--|
| Cal. Range | | current or both range | |
| Ch1 NO _x | Range1 0-100 ppm Range2 0-2000 ppm | both | |
| Ch2 SO ₂ | Range1 0-100 ppm Range2 0-2000 ppm | current | |
| Ch3 CO ₂ | Range1 0-10 vol% Range2 0-20 vol% | current | |
| Ch4 CO | Range1 0-100 ppm Range2 0-2000 ppm | both | |
| Ch5 O ₂ | Range1 0-10 vol% Range2 0-25 vol% | current | |



To close “Setting of Calibration Range”

To close “Setting of Calibration Range” or to cancel this mode midway, press the ESC key. A previous screen will return.

End of Setting of calibration range

Example

| | | |
|------------------------|---|---------|
| Ch1 NO _x | Range 1: 0 to 100 ppm Range 2: 0 to 2000 ppm | both |
| Ch2 SO ₂ | Range 1: 0 to 100 ppm Range 2: 0 to 2000 ppm | current |

Ch1: Range 1 and Range 2 are calibrated together with zero and span calibration.

Ch2: Only currently displayed range is calibrated with zero and span calibration.

CAUTION

To perform calibration for “both,” set the same calibration gas concentration for both ranges.

Manual Calibration screen

When setting NO_x and CO to “both”





| ZERO Cal. | ENT : Go on calibration of selected Ch ESC : Not calibration | | |
|------------------------|---|-----|-------|
| Ch1 NO _x | ▶ Range1 0-100 ppm ▶ Range2 0-2000 ppm | ◀ ▶ | -0.6 |
| Ch2 SO ₂ | ▶ Range1 0-100 ppm ▶ Range2 0-2000 ppm | ◀ ▶ | 0.4 |
| Ch3 CO ₂ | ▶ Range1 0-10 vol% ▶ Range2 0-20 vol% | ◀ ▶ | 0.00 |
| Ch4 CO | ▶ Range1 0-100 ppm ▶ Range2 0-2000 ppm | ◀ ▶ | -0.1 |
| Ch5 O ₂ | ▶ Range1 0-10 vol% ▶ Range2 0-25 vol% | ◀ ▶ | 21.00 |

Two cursors will appear in both ranges (Ch1 and Ch4).

6.2.4 Setting of auto calibration component/range

Select the Ch (component) and the range with which auto calibration is to be performed.

The Ch for which “AR” has been selected as range switch mode is calibrated in the range set here even when auto calibration is performed.



- (1) During measurement, press the  key to display the User mode.
- (2) Point the cursor to “Calibration Parameters” by pressing the  or  key. Press the  key.

Measurement Mode





| | |
|--|--|
| User Mode | Select an item with UP/DOWN and ENT Back with ESC |
| Switch Ranges | |
| <input checked="" type="checkbox"/> Calibration Parameters Alarm Setting Setting of Auto Calibration Setting of Auto Zero Calibration Setting of Peak Alarm Parameter Setting | |



- (3) In the “Calibration Parameters” screen that appears, point the cursor to “Auto Calibration Components / Range” by pressing the  or  key. Press the  key.

| | |
|---|--|
| Cal. Parameters | Select an item with UP/DOWN and ENT Back with ESC |
| Calibration Valve | |
| About ZERO Calibration | |
| About Calibration Range | |
| <input checked="" type="checkbox"/> Auto Calibration Components / Range | |



- (4) In the “Auto Calibration Components / Range” selection screen that appears, point the cursor to the Ch you want to set by pressing the  or  key. Press the  key.

| | | | |
|--|--------------------|--|--------|
| Cal. Settings Auto Cal. | Select Ch No. | | |
| <input checked="" type="checkbox"/> Ch1 NO _x | ▶Range1 0-100 ppm | | enable |
| | ▶Range2 0-2000 ppm | | |
| Ch2 SO ₂ | ▶Range1 0-100 ppm | | enable |
| | ▶Range2 0-2000 ppm | | |
| Ch3 CO ₂ | ▶Range1 0-10 vol% | | enable |
| | ▶Range2 0-20 vol% | | |
| Ch4 CO | ▶Range1 0-100 ppm | | enable |
| | ▶Range2 0-2000 ppm | | |
| Ch5 O ₂ | ▶Range1 0-10 vol% | | enable |
| | ▶Range2 0-25 vol% | | |



- (5) The cursor next to the range of the selected Ch (component) is highlighted. Select the range to be calibrated mainly by pressing the \blacktriangle or the \blacktriangledown key.
- (6) Then press the ENT key, and calibration is performed in the selected range.

To close "Auto Calibration Component/range" setting

Auto calibration and the manual calibration of the component with which "AR" has been selected as range switch mode are performed in the range selected here. In this case, once the calibration is started, the range is automatically switched, and on completion of the calibration, the original range is resumed.

The range identification contact is interlocked with the range after the switch. However, if the hold setting is set to "ON," the contact status before calibration is maintained.

- (7) Press the \blacktriangleright key in the state described in (5), and the highlight is switched between "enable" and "disable" auto calibration.
- (8) Select "enable" of "disable" by pressing the \blacktriangle or the \blacktriangledown key.
- (9) Then press the ENT key.

To close the setting

Press the ESC key to exit automatic calibration component/range setting, and the previous screen appears.

Operation by setting

Auto calibration is performed under the following rules.

1. Zero calibration is performed at the same time, for the Ch (component) with which "enable" is selected at the time of auto calibration and auto zero calibration.
2. Span calibration is performed in the order from smallest Ch No., for the Ch (component) with which "enable" is selected at the time of auto calibration.

CAUTION

ZERO calibration on auto calibration and auto zero calibration of the component with which "enable" is selected are performed in batch irrespective of the description in "6.2.2 Setting of manual zero calibration."

| | | | | |
|-------------------------|------------------------------|-------------------------------------|--|--------|
| Cal. Settings Auto Cal. | | Select a range for auto calibration | | |
| Ch1 NOx | \blacktriangleright Range1 | 0-100 ppm | | enable |
| | Range2 | 0-2000 ppm | | |
| Ch2 SO2 | \blacktriangleright Range1 | 0-100 ppm | | enable |
| | Range2 | 0-2000 ppm | | |
| Ch3 CO2 | \blacktriangleright Range1 | 0-10 vol% | | enable |
| | Range2 | 0-20 vol% | | |
| Ch4 CO | \blacktriangleright Range1 | 0-100 ppm | | enable |
| | Range2 | 0-2000 ppm | | |
| Ch5 O2 | Range1 | 0-10 vol% | | enable |
| | \blacktriangleright Range2 | 0-25 vol% | | |

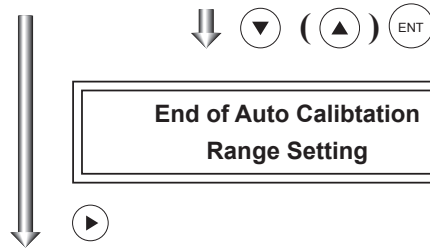



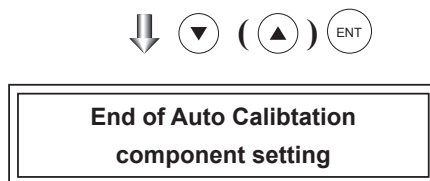

| | | | | |
|-------------------------------|--------|--|--|--------|
| Cal. Settings Auto Cal. | | Set enable or disable for auto calibration | | |
| \blacktriangleright Ch1 NOx | Range1 | 0-100 ppm | | enable |
| | Range2 | 0-2000 ppm | | |
| Ch2 SO2 | Range1 | 0-100 ppm | | enable |
| | Range2 | 0-2000 ppm | | |
| Ch3 CO2 | Range1 | 0-10 vol% | | enable |
| | Range2 | 0-20 vol% | | |
| Ch4 CO | Range1 | 0-100 ppm | | enable |
| | Range2 | 0-2000 ppm | | |
| Ch5 O2 | Range1 | 0-10 vol% | | enable |
| | Range2 | 0-25 vol% | | |



6.3 Alarm setting

6.3.1 Setting of alarm values

The High/Low limit alarm output setting for the measured concentration and power off alarm (alarm 6 only) setting can be made during measurement. Arbitrary 6 alarm contact outputs can be used. Before changing the alarm setting, set the alarm ON/OFF setting to OFF.



- (1) During measurement, press the  key to display the User mode.
- (2) Point the cursor to "Alarm Setting" by pressing the  or  key. Press the  key.

Measurement Mode





| | |
|--|--|
| User Mode | Select an item with UP/DOWN and ENT Back with ESC |
| <input checked="" type="checkbox"/> Alarm Setting Setting of Auto Calibration Setting of Auto Zero Calibration Setting of Peak Alarm Parameter Setting | |



- (3) After the alarm No. selection screen has appeared, point the cursor to the Alarm No. you want to set by pressing  or  key .
Press the  key.

| | |
|--|--|
| Alarm Setting | Select Alarm No. or Hysteresis setting |
| <input checked="" type="checkbox"/> Alarm-1 Alarm-2 Alarm-3 Alarm-4 Alarm-5 Alarm-6 | |
| Hysteresis | 00 %FS |



- (4) After the alarm item selection screen has appeared, operate the  or  key until the cursor is aligned with a desired item and press the  key.

| | |
|--|--|
| Alarm Setting Alarm-1 | Select an item with UP/DOWN and ENT Back with ESC |
| <input checked="" type="checkbox"/> Channel Ch 1 H-Limit Range 1 100.0 ppm Range 2 2000 ppm L-Limit Range 1 000.0 ppm Range 2 0000 ppm Kind of Alarm High ON / OFF OFF | |



Note

Set the values so that H-limit value > L-limit value and that (H-limit value – L-limit value) > hysteresis.

(5) After setting, the alarm setting is now completed by pressing the **ENT** key.

To close the "Alarm Setting"

To close the "Alarm Setting" or to cancel this mode midway, press the **ESC** key. A previous screen will return.

Setting range

0% to 100% FS (Settable in each range).

Cursor for setting value

| | |
|--------------------------|--|
| Alarm Setting Alarm-1 | Select an item with UP/DOWN and ENT Back with ESC |
| Channel | Ch 1 |
| H-Limit Range 1 | 100.0 ppm |
| Range 2 | 2000 ppm |
| L-Limit Range 1 | 000.0 ppm |
| Range 2 | 0000 ppm |
| Kind of Alarm | High |
| ON / OFF | OFF |



End of Alarm Setting

Description of setting items

The alarm contact assigned the same number as the alarm is operated accordingly.

- Channel: Channel setting targeted for issuance of alarm (Power off alarm can be selected for alarm 6.) One Ch No. can be selected for multiple alarms.
- H-Limit value: Sets the high limit value (concentration) of alarm.
- L-Limit value: Sets the low limit value (concentration) of alarm.
- Kind of Alarm: Selects one of High limit alarm, Low limit alarm, and High limit or Low limit alarm, HH limit alarm, and LL limit alarm.
 High, HH ... Alarm contact closes when above H-limit alarm.
 Low, LL ... Alarm contact closes when below L-limit alarm.
 High or Low ... Alarm contact closes when above H-limit value or below lower limit value.

If "Power" is selected for Channel, the contact is closed at all times while the power is on irrespective of the setting made here. (Alarm-6 only)

ON/OFF: Enables the alarm function if set at ON, or disables the alarm function if set at OFF.

* The H-limit value cannot be set below the L-limit value, and the L-limit value cannot be set above the H-limit value.

If it is desired to set the H-limit value below the L-limit value already stored in the memory, reduce the L-limit value beforehand, and vice versa.

Typical on-screen display when an alarm occurs

When an H-limit alarm occurs, the "H-alarm" message comes on in the field of relevant Ch (component). ("L-alarm" for L-limit alarm, "HH-alarm" for HH limit alarm, and "LL-alarm" for LL limit alarm)

| | | |
|---|--------------------------|------------|
| 1 | H-alarm | --- |
| 2 | SO ₂ 0-100 | 0.0 ppm |
| 3 | CO ₂ 0-10 | 0.003 vol% |
| 4 | CO 0-100 | 0.0 ppm |
| 5 | O ₂ 0-25 | 21.00 vol% |

CAUTION

For 10 minutes after turning on power, the alarm judgment is inactive.

6.3.2 Hysteresis setting

To prevent chattering of an alarm output near the alarm setting values, set the value of hysteresis.

(1) In the “Alarm No. Selection” screen that appears, point the cursor to “Hysteresis” by pressing the \blacktriangle or \blacktriangledown key. Press the ENT key.

(2) In the “Hysteresis Value Setting” screen that appears, enter hysteresis values.

For the value entry, 1-digit value is increased or decreased by pressing the \blacktriangle or \blacktriangledown key, and pressing the \blacktriangleright key moves the digit. After setting, press the ENT key.

To close "Hysteresis Setting"

To close the “Hysteresis Setting” or cancel the mode midway, press the ESC key. A previous screen will return.

Setting range

0 to 20% of full scale
[% full scale (FS)] represents the percentage with the width of the range of each component regarded as 100%.

| | |
|--|--|
| Alarm Setting | Select Alarm No. or Hysteresis setting |
| Alarm-1 Alarm-2 Alarm-3 Alarm-4 Alarm-5 Alarm-6 | |
| \blacktriangledown Hysteresis | 00 %FS |



| | |
|--|--|
| Alarm Setting | Set Hysteresis 0 to 20%FS available |
| Alarm-1 Alarm-2 Alarm-3 Alarm-4 Alarm-5 Alarm-6 | |
| Hysteresis | 00 %FS |



End of Hysteresis Setting

Note

The hysteresis is common to all alarms (components).
Hysteresis in peak alarm setting described in Section 6.6 should be set separately.

Hysteresis (In case of upper limit alarm)

An alarm output is turned ON if measurement value exceeds the upper limit value as shown below. Once the alarm output has been turned ON, it is not turned OFF as long as the indication does not fall below the hysteresis width from the upper limit value.

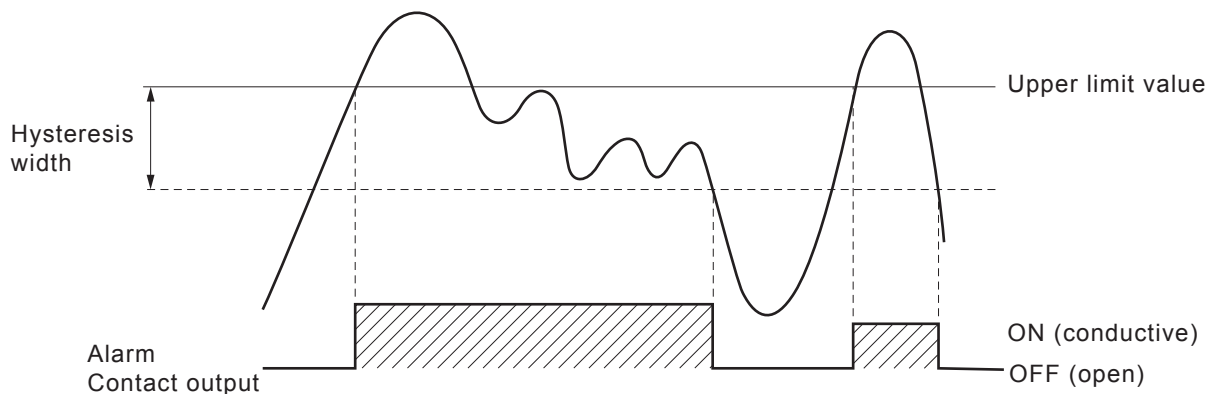

6.4 Setting of auto calibration

6.4.1 Auto calibration

Auto calibration is automatically carried out at the time cycle when zero calibration and span calibration are set.

Before changing the setting of auto calibration, set the ON/OFF to OFF.

- (1) During measurement, press the **(MODE)** key to display the User mode.
- (2) Point the cursor to "Setting of Auto Calibration" by pressing the **(▲)** or **(▼)** key. Press the **(ENT)** key.
- (3) In the "Setting of Auto Calibration" screen that appears, point the cursor to any item you want to set by pressing the **(▲)** or **(▼)** key. Press the **(ENT)** key.
- (4) In the "Auto Calibration Parameter Setting" screen that appears, perform the value entry or the setting. For the value entry or setting change, use the **(▲)** or **(▼)** key. To change the setting, use the **(▶)** key to move the cursor to the right.

After setting, press the **(ENT)** key, and auto calibration is carried out by the entered setting value.

Description of setting items

- Start Time : Setting at the first calibration (day of the week, hour, minute)
- Cycle : A period between the start time of one calibration and another (unit : hour/day)
- Flow Time : The time required for replacement by calibration gas
Time required for replacement of sample gas after the calibration is completed (Set by calibration gas. See the next page.)
- ON/OFF : ON/OFF setting of auto calibration

To close "Setting of Auto calibration"

To close the "Setting of Auto calibration" or cancel this mode midway, press the **(ESC)** key.

A previous screen will return.

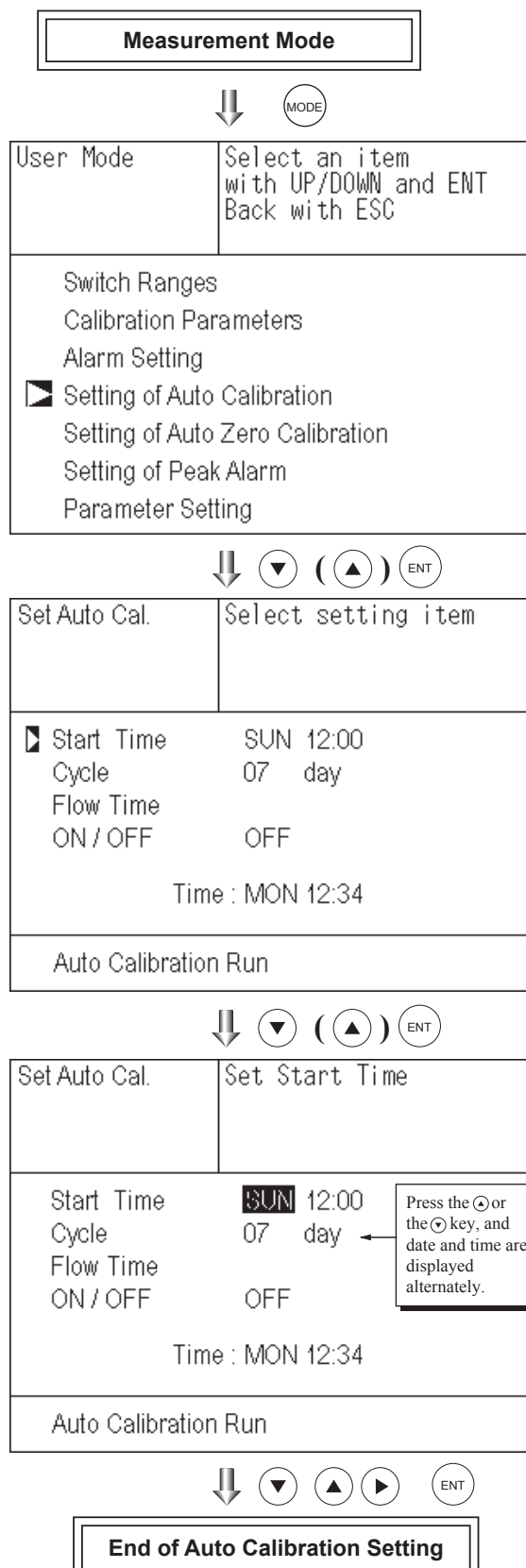





<Gas flow time> setting

- (1) Press the  key in a state where the cursor is placed next to "Flow Time," and the flow time setting screen shown at right figure.





| | |
|---|---------------------|
| Set Auto Cal. | Select setting item |
| Start Time | SUN 12:00 |
| Cycle | 07 day |
|  Flow Time | ON / OFF |
| | OFF |
| Time : MON 12:34 | |
| Auto Calibration Run | |



- (2) On the flow time setting screen that appears, move the cursor to the gas you want to change the setting by pressing the  or the  key, and then press the  key.

| | |
|--|--------------------|
| Set Auto Cal. | Select a Flow time |
|  Zero | 350 sec. |
| Ch1 Span | 350 sec. |
| Ch2 Span | 350 sec. |
| Ch3 Span | 350 sec. |
| Ch4 Span | 300 sec. |
| Ch5 Span | 300 sec. |
| Ex. time | 300 sec. |



- (3) The highlighted value can be changed. Change the value by pressing the  or the  key, and then move the cursor to the right by pressing the  key.
- (4) After changing the value, press the  key.
- (5) Press the  key to return to the automatic calibration setting screen.

| | |
|---------------|--|
| Set Auto Cal. | Set flow time of calibration gas |
| | 60 to 900 sec |
| Zero |  350 sec. |
| Ch1 Span | 350 sec. |
| Ch2 Span | 350 sec. |
| Ch3 Span | 350 sec. |
| Ch4 Span | 300 sec. |
| Ch5 Span | 300 sec. |
| Ex. time | 300 sec. |



End of Gas flow time Setting

 **CAUTION**

Only the Chs used are displayed on this screen. The Ex. time is the output signal hold extension time after the completion of calibration. It is valid only when the hold setting is set to "ON." The Ex. time set here is also the hold extension time at the time of manual calibration.

 **CAUTION**

Configure the flow time for zero and span gas about 5 times longer than the response time by referring to the item of "response time" in this manual.(For response time, see Section 6.7.)

Auto calibration status contact output is closed during auto calibration (including Ex. time), and is open in other cases.

Example

| | | |
|------------|----------|---------|
| Start Time | SUN | 12:00 |
| Cycle | 1 | day |
| Flow Time | Zero | 350 sec |
| | Ch1 Span | 350 sec |
| | Ch2 Span | 350 sec |
| | Ch3 Span | 350 sec |
| | Ch4 Span | 300 sec |
| | Ch5 Span | 300 sec |
| | EX. time | 300 sec |
| ON/OFF | ON | |

In case where auto calibration is carried out at the above setting.

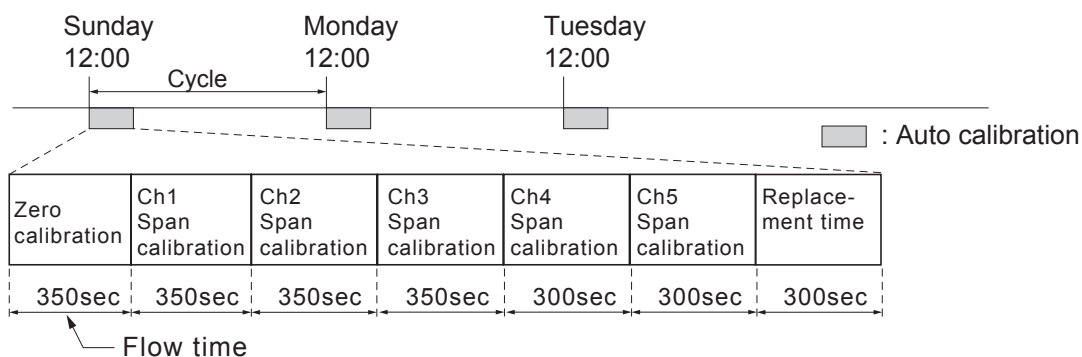

(An example of “Ch1 through Ch5: enable”, as given in Section 6.2.4 “Auto Calibration Components/range”)

Setting range

Cycle : 1 to 99 hours or 1 to 40 days (initial value 7days)
 Flow time : 60 to 900 sec (initial value 300sec)

CAUTION

- When an auto calibration starts, the measurement screen appears automatically.
- During auto calibration, any key operation is not permitted other than operations such as key lock ON/OFF and “Forced stop of auto calibration” (see Section 6.4.2.2). When the key lock is set at ON, even the “Forced stop of auto calibration” cannot be performed. To cancel auto zero calibration forcedly, set the key lock to OFF and then execute “Forced stop of auto calibration”.
- Turn on the power again after it is turned off (including the case of power failure) at the time set as the next start time in auto calibration, and then repeat it in the set cycle.
- When the hold setting is set to ON, the hold time of auto calibration contact and measurement value output signal are extended after calibration for gas replacement time.

Remote start

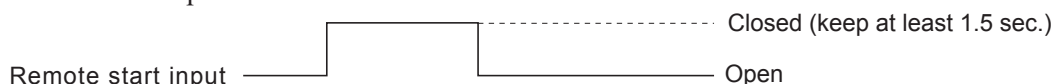

Whether the auto calibration is set at ON or OFF, an auto calibration is available by keeping the remote start input closed for at least 1.5 seconds.



6.4.2 Forced run/stop of auto calibration



Auto calibration can be performed just once or forcibly stopped while the calibration is performed.

6.4.2.1 Execution of auto calibration (only once)

- (1) Display the User mode screen. Move the cursor to “Setting of Auto Calibration” by pressing the  or the  key, and then press the  key.



| | |
|---|--|
| User Mode | Select an item with UP/DOWN and ENT Back with ESC |
| Switch Ranges Calibration Parameters Alarm Setting <input checked="" type="checkbox"/> Setting of Auto Calibration Setting of Auto Zero Calibration Setting of Peak Alarm Parameter Setting | |



- (2) In the “Setting of Auto Calibration” item selection screen that appears, point the cursor to “Auto Calibration Run” by pressing the  or  key. Press the  key.

| | |
|--|---------------------|
| Set Auto Cal. | Select setting item |
| Start Time SUN 12:00 Cycle 07 day Flow Time ON / OFF OFF Time : MON 12:34 | |
| <input checked="" type="checkbox"/> Auto Calibration Run | |





- (3) “Run” is highlighted, displaying a message to confirm the execution of auto calibration. Press the  key to execute the auto calibration, and press the  key to cancel.

| | |
|--|---|
| Set Auto Cal. | Auto Cal. Run ENT : Run / Stop ESC : Cancel |
| Start Time SUN 12:00 Cycle 07 day Flow Time ON / OFF OFF Time : MON 12:34 | |
| Auto Calibration Run | |



6.4.2.2 Forced stop of auto calibration

This mode is used to stop the auto calibration forcibly.

- (1) In the User mode that is displayed, point the cursor to “Setting of Auto Calibration” by pressing the  or  key. Press the  key.



| | |
|---|--|
| User Mode | Select an item with UP/DOWN and ENT Back with ESC |
| Switch Ranges Calibration Parameters Alarm Setting <input checked="" type="checkbox"/> Setting of Auto Calibration Setting of Auto Zero Calibration Setting of Peak Alarm Parameter Setting | |



- (2) In the “Setting of Auto Calibration” item selection screen that appears, point the cursor to “Auto Calibration Stop” by pressing the  or  key. Press the  key. (“Auto Calibration Stop” appears when the screen is selected while auto calibration is performed.)

| | |
|--|---------------------|
| Set Auto Cal. | Select setting item |
| Start Time SUN 12:00 Cycle 07 day Flow Time 300 sec ON / OFF OFF Time : SUN 12:04 | |
| <input checked="" type="checkbox"/> Auto Calibration Stop | |



- (3) “Stop” is highlighted, displaying a message to confirm the stop of auto calibration. Press the  key to stop the auto calibration, and press the  key to cancel (not stopped).

| | |
|--|--|
| Set Auto Cal. | Auto Cal. Stop ENT : Run / Stop ESC : Cancel |
| Start Time SUN 12:00 Cycle 07 day Flow Time 300 sec ON / OFF OFF Time : SUN 12:04 | |
| Auto Calibration Stop | |

“Auto Calibration” screen

Example

In case where setting the auto calibration components (see Section 6.2.4) to “Ch1: enable” and “Ch2: enable”

• Zero calibration

A message, “Zero cal.” blinks at Ch1 and Ch2.

| | | | |
|----|---|-------------------------|------------|
| Ch | 1 | ZERO cal. | 0.5 ppm |
| Ch | 2 | ZERO cal. | 0.3 ppm |
| Ch | 3 | CO ₂ 0-10 | 0.000 vol% |
| Ch | 4 | CO 0-100 | 0.0 ppm |
| Ch | 5 | O ₂ 0-25 | 21.02 vol% |

• Ch1 span calibration

A message, “Span cal.” blinks at Ch1.

| | | | |
|----|---|--------------------------|-----------|
| Ch | 1 | SPAN cal. | 90.8 ppm |
| Ch | 2 | SO ₂ 0-100 | 0.0 ppm |
| Ch | 3 | CO ₂ 0-10 | 0.00 vol% |
| Ch | 4 | CO 0-100 | 0.0 ppm |
| Ch | 5 | O ₂ 0-25 | 0.00 vol% |

• Ch2 span calibration

A message, “Span cal.” blinks at Ch2.

| | | | |
|----|---|--------------------------|-----------|
| Ch | 1 | NO _x 0-100 | 0.0 ppm |
| Ch | 2 | SPAN cal. | 95.0 ppm |
| Ch | 3 | CO ₂ 0-10 | 0.00 vol% |
| Ch | 4 | CO 0-100 | 0.0 ppm |
| Ch | 5 | O ₂ 0-25 | 0.00 vol% |

 CAUTION

During auto calibration, any key operation is not permitted other than operations such as key lock ON/OFF and “Stop Auto Calibration.”











When the key lock is set at ON, even the “Auto Calibration Stop” cannot be used.

To stop “Auto Calibration” forcibly, set the key lock to OFF and then execute “Auto Calibration Stop.”

6.5 Setting of auto zero calibration

6.5.1 Auto zero calibration

Auto zero calibration is automatically carried out at the time when zero calibration is set. Components for which a calibration is to be made are determined by setting of auto calibration component in Section 6.2.4. Before changing the setting of auto zero calibration, set the ON/OFF to OFF.

- (1) During measurement, press the  key to display the User mode.
- (2) Point the cursor to “Setting of Auto Zero Calibration” by pressing the  or  key. Press the  key.
- (3) In the “Setting of Auto Zero Calibration” screen that appears, point the cursor to any item you want to set by pressing the  or  key. Press the  key.
- (4) In the “Auto Zero Calibration Parameter Setting” screen that appears, perform the value entry or the setting. For the value entry or setting change, use the  or  key. To change the setting, use the  key to move the cursor to the right.

After setting, press the  key, and auto zero calibration is carried out by the entered setting value.

Description of setting items

- Start Time : Setting at the first calibration (day of the week, hour, minute)
- Cycle : A period between the start time of one calibration and another (unit : hour/day)
- Flow Time : The time required for the calibration gas to be replaced in the cell
- ON/OFF : ON/OFF of auto zero calibration

To close "setting of Auto Zero Calibration"

To close the “Setting of Auto Zero Calibration” or cancel this mode midway, press the  key. A previous screen will return.

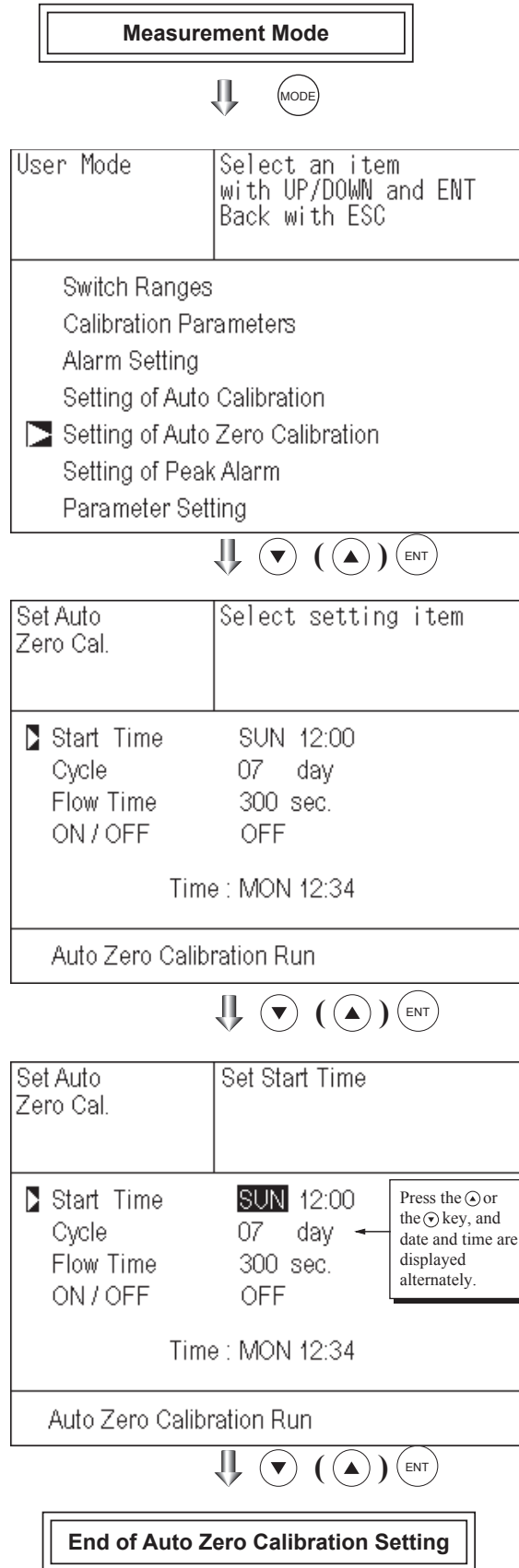

Auto calibration status contact output is closed during auto zero calibration, and is open in other cases.

Example

| | | |
|------------|-----|-------|
| Start time | SUN | 12:00 |
| Cycle | 12 | hour |
| Flow time | 300 | sec |
| ON/OFF | ON | |

In case where auto zero calibration is carried out at the above setting.

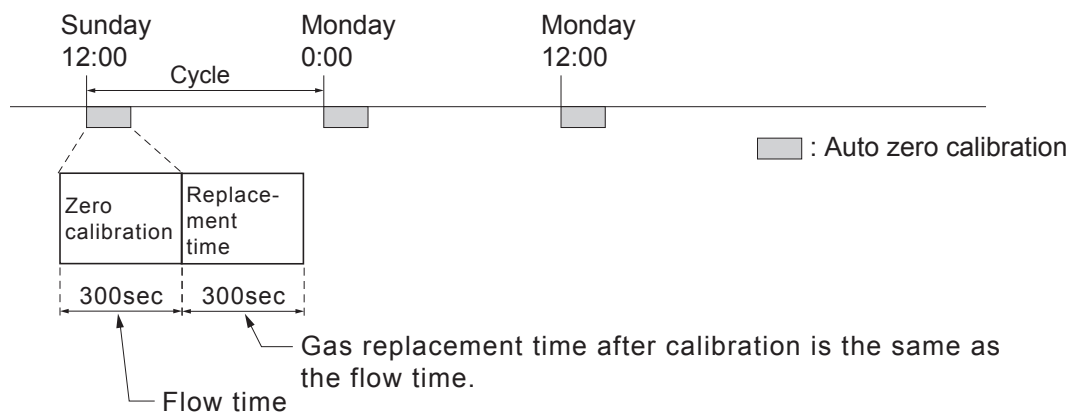

(An example of “Ch1 through Ch5: enable,” as given in Section 6.2.4 “Auto Calibration Components/range”)

Setting range

Cycle : 1 to 99 hours or 1 to 40 days (initial value 7days)
 Flow time : 60 to 900 sec (initial value 300sec)



⚠ CAUTION

- When an auto zero calibration starts, the measurement screen automatically appears.
- Any operation other than "Stop Auto Zero Calibration" (see Section 6.5.2) is not permitted during auto zero calibration. "Stop Auto Zero Calibration" cannot be performed with the key lock to ON. To cancel auto zero calibration forcedly, set the key lock to OFF and then execute "Stop Auto Zero Calibration."
- If the auto calibration period and auto zero calibration period have overlapped, the auto calibration is retained, ignoring the auto zero calibration of that period.
- When the hold setting is set to ON, the hold time of auto calibration contact and measurement value output signal is extended after calibration for gas replacement time.
- Turn on the power again after it is turned off (including the case of power failure) at the time set as the next start time in auto zero calibration, and then repeat it in the set cycle.

6.5.2 Forced run/stop of auto zero calibration



Auto zero calibration can be performed just once, or auto zero calibration can be forcibly stopped during calibration.

6.5.2.1 Execution of auto zero calibration (just once)

- (1) Move the cursor to “Setting of Auto Zero Calibration” by pressing the  or the  key on the user mode screen, and then press the  key.



| | |
|---|--|
| User Mode | Select an item with UP/DOWN and ENT Back with ESC |
| Switch Ranges Calibration Parameters Alarm Setting Setting of Auto Calibration <input checked="" type="checkbox"/> Setting of Auto Zero Calibration Setting of Peak Alarm Parameter Setting | |



- (2) In the “Setting of Auto Zero Calibration” item selection screen that appears, point the cursor to “Auto Zero Calibration Run” by pressing the  or  key. Press the  key.

| | |
|---|---------------------|
| Set Auto Zero Cal. | Select setting item |
| Start Time SUN 12:00 Cycle 07 day Flow Time 300 sec. ON / OFF OFF Time : MON 12:34 | |
| <input checked="" type="checkbox"/> Auto Zero Calibration Run | |





- (3) “Run” is highlighted, displaying a message to confirm execution of auto zero calibration. Press the  key to execute the calibration, and press the  key to cancel.

| | |
|---|---|
| Set Auto Zero Cal. | Auto zero Run ENT : Run / Stop ESC : Cancel |
| Start Time SUN 12:00 Cycle 07 day Flow Time 300 sec. ON / OFF OFF Time : MON 12:34 | |
| Auto Zero Calibration Run | |



6.5.2.2 Forced stop of auto zero calibration

This mode is used to cancel the auto zero calibration forcedly.

- (1) In the User mode that is displayed, point the cursor to “Setting of Auto Zero Calibration” by pressing the  or  key. Press the  key.



| | |
|---|--|
| User Mode | Select an item with UP/DOWN and ENT Back with ESC |
| Switch Ranges Calibration Parameters Alarm Setting Setting of Auto Calibration <input checked="" type="checkbox"/> Setting of Auto Zero Calibration Setting of Peak Alarm Parameter Setting | |



- (2) In the “Setting of Auto Zero Calibration” item selection screen that appears, point the cursor to “Auto Zero Calibration Stop” by pressing the  or  key. Press the  key. (“Auto Zero Calibration Stop” appears when the screen is selected while auto zero calibration is performed.)

| | |
|---|---------------------|
| Set Auto Zero Cal. | Select setting item |
| Start Time SUN 12:00 Cycle 07 day Flow Time 300 sec. ON/OFF OFF Time : SUN 12:03 | |
| <input checked="" type="checkbox"/> Auto Zero Calibration Stop | |



- (3) “Stop” is inverted. A message appears, prompting you to verify that you want to stop auto zero calibration. Press the  key to stop the auto zero calibration and the  key to cancel (not stopped).

| | |
|---|--|
| Set Auto Zero Cal. | Auto Zero Stop ENT : Run / Stop ESC : Cancel |
| Start Time SUN 12:00 Cycle 07 day Flow Time 300 sec. ON/OFF OFF Time : SUN 12:03 | |
| Auto Zero Calibration Stop | |

“Auto Zero Calibration” screen

Example

In case where setting the auto calibration components (see Section 6.2.4) to “Ch1: enable” and “Ch2: enable”

• Zero calibration

A message, “Zero cal.” blinks at Ch1 and Ch2.

| | | |
|-----|-------------------------|------------|
| Ch1 | ZERO cal. | 0.5 ppm |
| Ch2 | ZERO cal. | 0.3 ppm |
| Ch3 | CO ₂ 0-10 | 0.00 vol% |
| Ch4 | CO 0-100 | 0.0 ppm |
| Ch5 | O ₂ 0-25 | 21.02 vol% |

 **CAUTION**

During auto zero calibration, any key operation is not permitted other than operations such as key lock ON/OFF and “Stop Auto Zero Calibration.”





When the key lock is set at ON, even the “Stop Auto Zero Calibration” cannot be used.

To stop “auto zero calibration” forcibly, set the key lock to OFF and then execute “Auto Zero Calibration Stop.”

6.6 Peak alarm setting

When the peak number of times CO concentration exceeds the upper limit value during measurement exceeds the set number per one hour, an alarm is provided.

The peak alarm and this setting screen appear only when an option is added.





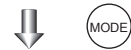

- (1) Press the  key in the Measurement mode, and the User mode appears.
- (2) Point the cursor to “Setting of Peak Alarm” by pressing the  or  key. Press the  key.

Measurement Mode



| | |
|---|--|
| User Mode | Select an item with UP/DOWN and ENT Back with ESC |
| Switch Ranges Calibration Parameters Alarm Setting Setting of Auto Calibration Setting of Auto Zero Calibration <input checked="" type="checkbox"/> Setting of Peak Alarm Parameter Setting | |



- (3) In the “Peak Alarm Setting” item selection screen that appears, point the cursor to any item you want to set by pressing the  or  key. Press the  key.
- (4) Entering the numeric values or setting the items should be carried out by using the  or  key.
After setting, press the  key, and the set values are saved.

| | |
|---|---------------------|
| Peak Alarm | Select setting item |
| <input checked="" type="checkbox"/> Peak Alarm OFF Alarm Value 0500 ppm Alarm Count 05 times Hysteresis 00 %FS | |



| | |
|--|-----------------------------|
| Peak Alarm | Set Peak Alarm ON or OFF |
| Peak Alarm OFF Alarm Value 0500 ppm Alarm Count 05 times Hysteresis 00 %FS | |



End of Peak Alarm Setting

Description of setting items

- Peak Alarm : ON/OFF of peak alarm
- Alarm Value : If measuring value exceeds the set alarm value, a peak counter counts 1 time.
- Alarm Count : When a peak in excess of the setting time occurs, a peak count alarm output is provided.
- Hysteresis : To prevent possible chattering when the measuring value may exceed the set peak concentration by only 1 time, the peak count has an allowance in the hysteresis width.

Setting range

- Alarm value : 10 to 1000 ppm → 5 ppm step (initial value: 500 ppm)
 - Alarm count : 1 to 99 times → 5 ppm step (initial value: 5 times)
 - Hysteresis : 0 to 20 % of full scale → 5 ppm step (initial value: 0% of full scale)
- [% full scale] represents the percentage with the CO range regarded as 100%.

Action of peak alarm

Example

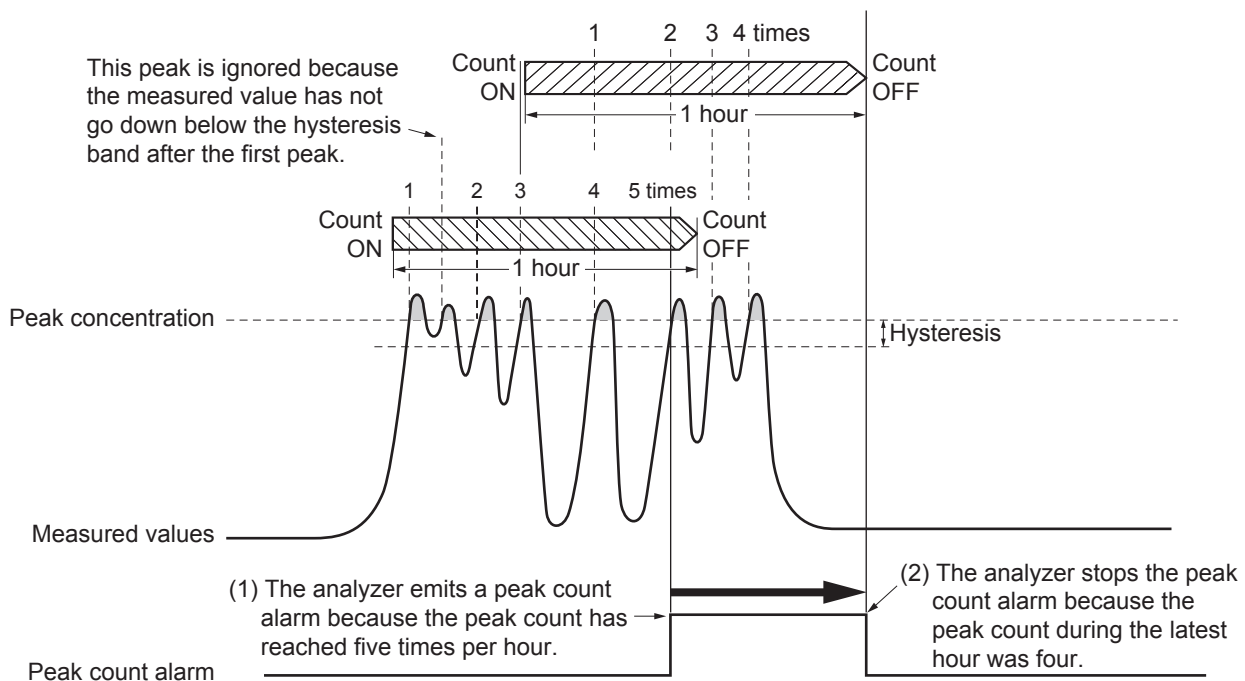

If CO concentration exceeds the alarm value, counting will begin. If the number of peaks is over the set times per hour, a peak alarm contact output becomes closed (ON). If it is less than the set times per hour, it is open (OFF). Since 5 times of peaks /hour is marked at (1) section from the above graph, the peak count alarm is turned ON. Since peaks of more than 5 times per 1 hour occur at the interval between (1) and (2) , the peak count alarm remains ON. Since at (2), peaks are reduced to 4 times per hour, it is turned OFF.

Like the hysteresis of the alarm setting, the hysteresis prevents possible chattering when measured gas is fluctuated near the alarm value.

* For 10 minutes after the power is turned ON, a peak alarm counting is not carried out.

Releasing peak count alarm

To release the peak count alarm, set the peak alarm to OFF.
Turning on the peak alarm initiates counting from 0.

6.7 Parameter setting

It allows you to carry out the parameter setting such as time, key lock, etc., as required. Items to be set are as follows:

Description of setting items

- Current Time : Current year, month, date, day of the week, hour, and minute setting
(The display appears in this order.)
Note: The clock backup time is 2 days. If power is turned on after it is kept off for 2 days or longer, make the time setting again.
- Key Lock : Sets with ON/OFF so that any key operation except the key lock OFF cannot be performed.
- Output Hold : Sets whether Calibration Output is held or not, and the holding value setting.
- Reset Av. Output : Resets the average value.
- Response time : Sets the response time of electrical system.
- Average Period : Sets the moving average time.
- Backlight Timer : Sets automatic OFF of the backlight of display unit and the time until backlight out.
- Contrast : Sets the display contrast
- Maintenance mode : Enters passwords to switch to the Maintenance mode.

* For the maintenance mode, see Section 6.8.

Measurement Mode



- (1) To display the User mode, press the key in the measurement mode.
- (2) Point the cursor to "Parameter Setting" by pressing the or key. Press the key.

| | |
|---|--|
| User Mode | Select an item with UP/DOWN and ENT Back with ESC |
| Switch Ranges Calibration Parameters Alarm Setting Setting of Auto Calibration Setting of Auto Zero Calibration Setting of Peak Alarm <input checked="" type="checkbox"/> Parameter Setting | |



- (3) In the "Parameter Setting" screen that appears, point the cursor to any item you want to set by pressing the or key. Press the key.

| Parameter | Select setting item |
|--|---------------------|
| <input checked="" type="checkbox"/> Current Time | 05/01/27 THU 13:50 |
| Key Lock | OFF |
| Output Hold | OFF Current |
| Reset Av. Output | Reset |
| Response Time | |
| Average Period | |
| Backlight Timer | ON 5min |
| Contrast | |
| To Maintenance Mode | 0000 |



(4) In the Parameter Setting screen that appears, enter the numeric values and set the items. Entering the numeric values or setting the items should be carried out by using the ▲ or ▼ key. To move the cursor to the right, press the ► key. After setting, press the ENT key, that the parameter setting is carried out with the value you set.

| Parameter | Set day of week |
|---------------------|--------------------|
| Current Time | 05/01/27 THU 13:50 |
| Key Lock | OFF |
| Output Hold | OFF Current |
| Reset Av. Output | Reset |
| Response Time | |
| Average Period | |
| Backlight Timer | ON 5min |
| Contrast | |
| To Maintenance Mode | 0000 |

To close Parameter Setting screen

To close the "Parameter Setting" screen or cancel this mode midway, press the

ESC key.

A previous screen will return.



End of Parameter Setting

Setting Range

- Hold setting : 0 to 100% FS
- Response time : 1 to 60sec. (Initial value: 15 sec)
- Average period : 1 to 59 min or 1 to 4 hours (Initial value: 1 hour)
When setting the unit of 1 to 59 minutes is terms of minute
or 1 to 4 hours with hour
- Backlight Timer : 1 to 60 min (Initial value: OFF)
- Maintenance mode : 0000 to 9999 (Initial value: 0000)

Output Hold

By setting an output hold to ON, an output signal of each channel are held during the calibration (manual calibration and auto calibration) and for the gas flow time (refer to Section 6.4, Setting of Auto Calibration). Regardless of Hold ON/OFF setting, an output signal can be held via an external input.

(1) With manual calibration

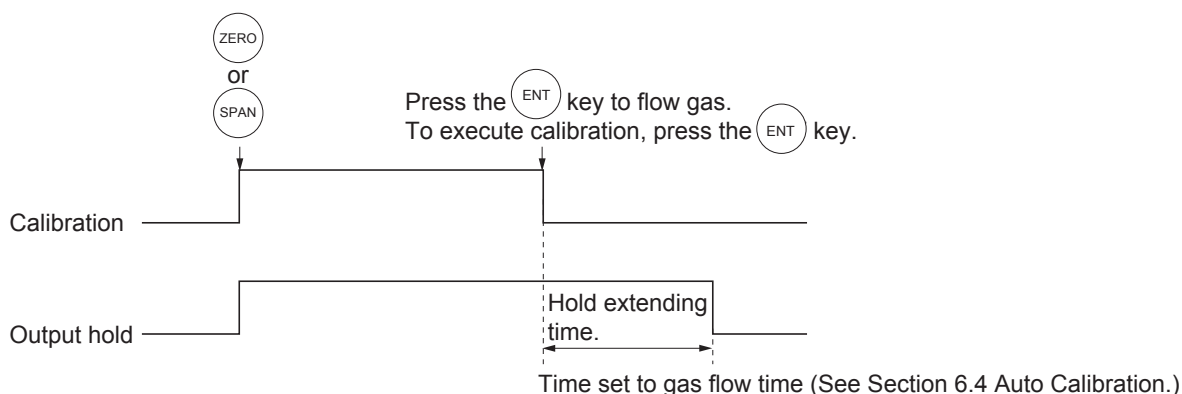

(2) With auto calibration

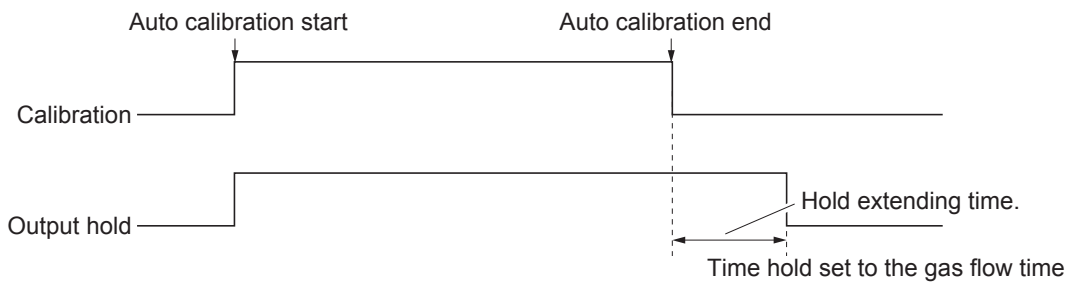

(3) External hold

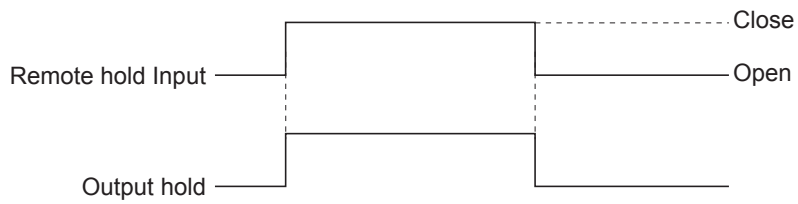

(4) Screen display during Holding

The “on Hold” message blinks on the measuring screen.

Since the screen displays the process of calibration is displayed during the manual calibration, “on Hold” is not displayed even if the output signal is held, but the screen is displayed with the hold extending time.

- (5)** If calibration is cancelled after the calibration gas is supplied regardless of during manual calibration or auto calibration, the holding extending time will be performed.

- (6) You can select the value for hold from the value immediately before entering output hold, “current,” and arbitrary value, “setting.”



Follow the procedures shown below to make the setting.

(1) Setting for “Current” output hold value

- 1) Press the  key in a state where the cursor is placed next to Hold.

| Parameter | Select setting item |
|---|---------------------|
| Current Time | 05/01/27 THU 13:50 |
| Key Lock | OFF |
| <input checked="" type="checkbox"/> Output Hold | ON Current |
| Reset Av. Output | Reset |
| Response Time | |
| Average Period | |
| Backlight Timer | ON 5min |
| Contrast | |
| To Maintenance Mode | 0000 |



- 2) “ON” or “OFF” is highlighted. Press the  or  key to select ON or OFF. Press the  key to return to 1).

| Parameter | Select Hold ON or OFF |
|---------------------|-----------------------|
| Current Time | 05/01/27 THU 13:50 |
| Key Lock | OFF |
| Output Hold | ON Current |
| Reset Av. Output | Reset |
| Response Time | |
| Average Period | |
| Backlight Timer | ON 5min |
| Contrast | |
| To Maintenance Mode | 0000 |



End of Hold Setting



Parameter Setting screen

(2) Setting for “Setting” output hold value

- 1) Press the key in a state ON/OFF is highlighted, and “Current” or “Setting” is highlighted. Select “Current” or “Setting” by pressing the or the key.

| Parameter | Select Hold ON or OFF |
|---------------------|-----------------------|
| Current Time | 05/01/27 THU 13:50 |
| Key Lock | OFF |
| Output Hold | ON Current |
| Reset Av. Output | Reset |
| Response Time | |
| Average Period | |
| Backlight Timer | ON 5min |
| Contrast | |
| To Maintenance Mode | 0000 |



- 2) Press the key while “Current” is selected to return to (1). Press the key while “Setting” is selected to go to the setting entering screen.

“Current”: Holds the value immediately before the hold.

“Setting”: Holds the value arbitrarily set.



| Parameter | Select Hold setting |
|---------------------|---------------------|
| Current Time | 05/01/27 THU 13:50 |
| Key Lock | OFF |
| Output Hold | ON Setting |
| Reset Av. Output | Reset |
| Response Time | |
| Average Period | |
| Backlight Timer | ON 5min |
| Contrast | |
| To Maintenance Mode | 0000 |







- 3) On the parameter hold screen that appears, move the cursor next to the Ch (component) you want to make the setting by pressing the or the key, and then press the key.

| Parameter Hold | Select Ch No. |
|----------------|-------------------------|
| Ch1 | NOx 010 %FS |
| Ch2 | SO ₂ 020 %FS |
| Ch3 | CO ₂ 015 %FS |
| Ch4 | CO 012 %FS |
| Ch5 | O ₂ 022 %FS |



- 4) The value is highlighted, indicating that the value can be changed. Change the value by pressing the  or the  key, and then move the cursor to the right by pressing the  key.

- 5) After the value is changed, press the  key.

| Parameter | | Set Hold value | |
|-----------|-----------------|----------------|-----|
| Hold | | 0 to 100%FS | |
| Ch1 | NO _x | 010 | %FS |
| Ch2 | SO ₂ | 020 | %FS |
| Ch3 | CO ₂ | 015 | %FS |
| Ch4 | CO | 012 | %FS |
| Ch5 | O ₂ | 022 | %FS |

Meaning of setting

The setting is represents the percentage with each Ch (component) range regarded as 100% for both ranges.

When 0 to 1000 ppm is selected as the range, for example, if 10% FS is selected as hold setting, the output equivalent to 100 ppm is output and held irrespective of the measurement value at that time.



End of Hold Setting



Parameter Setting screen

- 6) Press the  key to return to the parameter setting screen.

Description of setting

- Instantaneous value display of the measurement cannot be held. (Output only can be held.)
- If set value is selected for hold, instantaneous O₂ conversion value is calculated and held based on the set value.
- Range identification contact output cannot be switched even if the range is switched during the hold.

Average value reset

This mode is used to clear O₂ average values and O₂ conversion average values and restarts averaging. All average values are reset at a time. The indication value and output value is 0 ppm, 0 vol% or so at the time of the reset input (Refer to the average period).

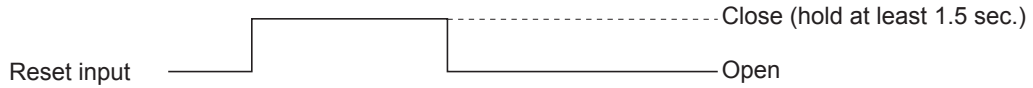

So long as close, resetting lasts.

At the edge of changing from closing to opening, the average action restarts.

Response time

The response time of the electrical system can be changed.

Setting is available by components.

**Note) It does not provide exact seconds for the setting time, but it gives a guide of the setting time.
The setting value can be modified as requested by the customer.**

| Parameter | Select Ch No. | | |
|---------------|-----------------|----|------|
| Response Time | | | |
| ▣ Ch1 | NO _x | 10 | sec. |
| Ch2 | SO ₂ | 20 | sec. |
| Ch3 | CO ₂ | 15 | sec. |
| Ch4 | CO | 12 | sec. |
| Ch5 | O ₂ | 22 | sec. |

Average period

It allows you to set an average period of the average value of O₂ conversion and O₂ average. It enables you to set an average time of 1 to 59 minutes (1-minute step) or 1 to 4 hours (1-hour step).

Changing the setting resets the average value of O₂ conversion and O₂ average value. (Pressing the  validates the resetting only for components whose setting was changed.)

| Parameter | Select Ch No. | | |
|----------------|-------------------|----|------|
| Average Period | | | |
| ▣ Ch9 | % NO _x | 01 | hour |
| Ch10 | % SO ₂ | 01 | hour |
| Ch11 | % CO ₂ | 01 | hour |
| Ch12 | % O ₂ | 01 | hour |

Example of average action

In case the average period was set to 1 hour.

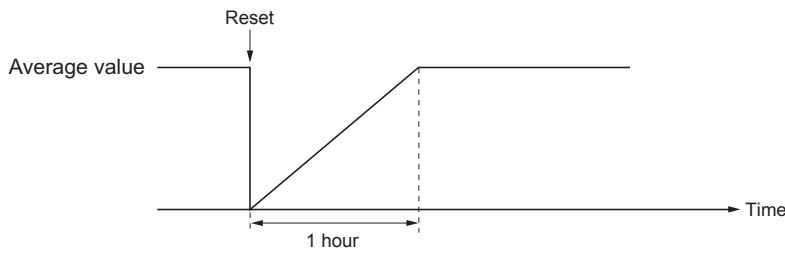

- Sampling occurs every 30 seconds.
- Every 30 seconds, the average for last 1 hour (time setting) is output.
- At the instant of resetting, zero is assumed for all past values. It means that the average value will not be correct for 1 hour after resetting.

Backlight Timer

Automatic OFF setting of the backlight of the LCD unit can be made.

When the specified time elapses from when the measurement screen is resumed, the backlight is automatically turned off. Press any key to reset backlight OFF.

Only when ON is selected, the time until auto OFF is displayed. Press the **▶** key in this state, and the time setting can be changed by pressing the **▲** or the **▼** key. Press the **ENT** key to confirm the selection.

If OFF is selected, the backlight is not turned off.

| Parameter | Select ON or OFF |
|---------------------|--------------------|
| Current Time | 05/01/27 THU 13:50 |
| Key Lock | OFF |
| Output Hold | ON Previous value |
| Reset Av. Output | Reset |
| Response Time | |
| Average Period | |
| Backlight Timer | ON 5min |
| Contrast | |
| To Maintenance Mode | 0000 |

Contrast

Contrast of the LCD can be adjusted. The contrast changes by pressing the **▲** or the **▼** key. Adjust to the best contrast and save it by the **ENT** key.

| Parameter | |
|---------------------|--------------------|
| Current Time | 12/01/11 WED 13:50 |
| Key Lock | OFF |
| Output Hold | ON Setting |
| Response Time | |
| Average Period | |
| Backlight Timer | ON 05 min |
| Contrast | |
| To Maintenance Mode | 0000 |

Maintenance mode

Enter the password and then press the **ENT** key to enter the maintenance mode. The password can be set by the password setting in maintenance mode. Default password setting at the time of delivery from the factory is "0000." You can enter the maintenance mode with the value before it is changed.

6.8 Maintenance mode

This mode is used for check of sensor input values, display of error log files or setting of passwords, etc. First, enter a password and then use it from the next operation. This mode is displayed by selecting the Maintenance Mode from “Section 6.7 Parameter Setting.”

- (1) Select the Maintenance mode from the Parameter Setting screen to display the Password Setting screen.
- (2) Enter the password, and the Maintenance Mode item selection screen will be displayed. Point the cursor to the item you want to set by pressing the \blacktriangle or \blacktriangledown key and press the ENT key.
- (3) Next, each Maintenance screen is displayed.

Note) “To Factory Mode” is used for our service engineers only. Refrain from using this mode.

- (4) Press the ESC key to return to the Maintenance Mode item selection screen from each screen.

• Sensor Input Value screen

Description of Sensor Input Value screen

- NO_x M : NO_x sensor input value
- NO_x C : NO_x interference compensation sensor input value
- SO₂ M : SO₂ sensor input value
- SO₂ C : SO₂ interference compensation sensor input value
- CO₂ M : CO₂ sensor input value
- CO₂ C : CO₂ interference compensation sensor input value
- CO M : CO sensor input value
- CO C : CO interference compensation sensor input value
- Temperature : temperature sensor input value
- O₂ : O₂ sensor input value

• Error Log screen

Description of Error Log screen

Error history. Fourteen newest errors are logged. For error number, date and time (year, month, day, period) of occurrence, channel and other details of error, refer to Section 8 Error message. Select Clear Error Log and press the ENT key, and the error log is cleared completely.

| Maintenance Mode | Select operating item |
|------------------|--|
| | <ul style="list-style-type: none"> \blacktriangle 1. Sensor Input Value 2. Error Log 3. Cal. Log 4. Optical Adjustment 5. Interference Compensation Adj. 6. Output Adj. 7. Other Parameter 8. To Factory Mode |



Each “Maintenance” screen

| Maintenance Sensor Input | | | | | | | |
|--------------------------|-------------------|-------|--|----------------|-------|--|--|
| | sensor | input | | sensor | input | | |
| | NO _x M | 648 | | O ₂ | 20785 | | |
| | C | 499 | | TEMP | 15785 | | |
| | SO ₂ M | 1518 | | | | | |
| | C | 425 | | | | | |
| | CO ₂ M | 1120 | | | | | |
| | C | 80 | | | | | |
| | CO M | 39 | | | | | |
| | C | 80 | | | | | |

| Maintenance Error Log | | ENT: Clear Error Log ESC:Back | | | | |
|----------------------------------|----|----------------------------------|----|----|----|--------|
| errorNo. | YY | MM | DD | HH | MM | Ch |
| No. 10 | 17 | 9 | 27 | 22 | 24 | |
| No. 10 | 17 | 9 | 21 | 19 | 1 | |
| No. 10 | 17 | 9 | 21 | 19 | 0 | |
| No. 10 | 17 | 9 | 21 | 14 | 46 | |
| No. 7 | 17 | 9 | 19 | 14 | 10 | 5 |
| No. 10 | 17 | 9 | 19 | 11 | 28 | |
| No. 1 | 17 | 9 | 14 | 16 | 43 | OPT1 |
| ▼ Next page | | | | | | Page 1 |
| \blacktriangle Clear Error Log | | | | | | |

• **Calibration Log screen**

Description of Calibration Log screen

Past calibration history.

Sensor input value, concentration value, and the date when zero/span calibration is performed are logged. The 10 newest calibration data is logged by each Ch (component).

Move the cursor to Clear Calibration Log and press the (ENT) key, and the calibration log is cleared completely.

- Z1 : Zero calibration (Z) of Range 1
- S1 : Span calibration (S) of Range 1
- M : Sensor input value of measuring detector at the time of calibration
- C : Sensor input value of the interference compensation detector at the time of calibration
- Con : Concentration value displayed before calibration

| | |
|---|---------------|
| Maintenance Cal. Log | Select Ch No. |
| <input checked="" type="checkbox"/> Ch1 NOx <input type="checkbox"/> Ch2 SO2 <input type="checkbox"/> Ch3 CO2 <input type="checkbox"/> Ch4 CO <input type="checkbox"/> Ch5 O2 | |
| Clear Error Log | |



| | | | | | | | | |
|----------------------|--------|------|------|-------|---|----|----|----|
| Maintenance Cal. Log | Ch1 NO | | | | | | | |
| | R | M | C | Con | M | D | H | M |
| | Z1 | 2523 | 1271 | -0.38 | 9 | 21 | 9 | 12 |
| | Z1 | 2425 | 1202 | -0.37 | 9 | 19 | 15 | 10 |
| | Z1 | 2448 | 1212 | 4.16 | 9 | 19 | 14 | 37 |
| | S1 | 2516 | 1137 | 45.68 | 9 | 19 | 13 | 49 |
| | Z1 | 1751 | 859 | -0.24 | 9 | 19 | 13 | 33 |
| | Z1 | 1762 | 860 | 0.28 | 9 | 19 | 13 | 33 |
| | Z1 | 1857 | 939 | -4.23 | 9 | 19 | 13 | 11 |
| | Z1 | 2260 | 1119 | 0.16 | 9 | 15 | 14 | 44 |
| | Z1 | 2248 | 1117 | -0.12 | 9 | 15 | 14 | 13 |
| | Z1 | 2348 | 1191 | 1.80 | 9 | 14 | 17 | 15 |

! CAUTION

If the following operation is maladjusted, the measurement may be adversely and excessively affected. Carry out the operation with utmost attention.

• **Optical adjustment screen**

For details of this item, refer to “Section 7.3.3 Optical zero adjustment method”.

Press (ENT) key and turn ON the solenoid valve signal for each calibration gas by using the (▲) or (▼) key.





| | | | |
|---|---------------------------|-----|----|
| Maintenance Optical Adj. | ENT : Selectable flow gas | | |
| 1-1 | 9 | 2-1 | 24 |
| | 3 | | 1 |
| 1-2 | 21 | 2-2 | 40 |
| | 27 | | 80 |
| <input checked="" type="checkbox"/> GAS | Sample | | |



• **Moisture interference adjustment screen**

For details of this item, refer to “Section 7.3.4
Moisture interference adjustment method.”

**Description of moisture interference
adjustment screen**

In values on the left side of screen, the moisture interference for each component is already offset. The figures at right are interference compensation coefficients.

Move the  cursor to a desired Ch (component) by pressing the  or the  key, and then press the  key, and the selected value at right is highlighted.

Check that the gas for moisture interference compensation is flowing, change the moisture interference compensation coefficient using the  or the  key, adjust the value at left so that it becomes near zero, and then press the  key to log moisture interference compensation value.

 **CAUTION**

Since an interference compensation detector is not provided if the 1st range is beyond 0 to 10 vol%, no interference adjustment can be performed (no need).

| | | | |
|---|--|-----|-------|
| Maintenance | Select Ch No. with UP / DOWN and ENT Back with ESC | | |
|  Ch1 | NO _x | 10 | 1.252 |
| Ch2 | SO ₂ | -33 | 0.983 |
| Ch3 | CO ₂ | 13 | 0.000 |
| Ch4 | CO | 20 | 1.922 |
| ALL | | | |
| Valve OFF | | | |









| | | | |
|-------------|--|-----|--|
| Maintenance | Adjust with UP / DOWN ENT : Memorized ESC : Back | | |
| Ch1 | NO _x | 0 | 1.26  |
| Ch2 | SO ₂ | -33 | 0.983 |
| Ch3 | CO ₂ | 13 | 0.000 |
| Ch4 | CO | 20 | 1.922 |
| ALL | | | |
| Valve OFF | | | |

• **Output adjustment screen**

Description of output adjustment screen

Analog output adjustment screen.
Connect the digital multi meter to the output terminal corresponding to the number of OUT to be adjusted, and adjust the value so that 4mA or 0V is output at zero and 20mA or 1V is output at span.

Move the cursor using the , , or the  key to the output (OUT No. and zero/span) to be adjusted, and then press the  key.

The selected value is highlighted. Adjust the value, while watching the output, by pressing the  or the  key. Press the  key to select the next digit.

On completion of the adjustment, press the  key.

| Maintenance Mode Output Adj. | | | Adjust OUTPUT ZERO and SPAN | | |
|------------------------------|-------|-------|-----------------------------|-------|-------|
| OUT | Zero | Span | OUT | Zero | Span |
| 1 | 01245 | 11845 | 7 | 01900 | 12500 |
| 2 | 01245 | 11845 | 8 | 01900 | 12500 |
| 3 | 01245 | 11845 | 9 | 01900 | 12500 |
| 4 | 01245 | 11845 | 10 | 01900 | 12500 |
| 5 | 01245 | 11845 | 11 | 01900 | 12500 |
| 6 | 01245 | 11845 | 12 | 01900 | 12500 |



| Maintenance Mode Output Adj. | | | Zero / Span adjustment | | |
|------------------------------|-------|-------|------------------------|-------|-------|
| OUT | Zero | Span | OUT | Zero | Span |
| 1 | 01245 | 11845 | 7 | 01900 | 12500 |
| 2 | 01245 | 11845 | 8 | 01900 | 12500 |
| 3 | 01245 | 11845 | 9 | 01900 | 12500 |
| 4 | 01245 | 11845 | 10 | 01900 | 12500 |
| 5 | 01245 | 11845 | 11 | 01900 | 12500 |
| 6 | 01245 | 11845 | 12 | 01900 | 12500 |

• **Other parameter**

Description of each setting screen

Password Set : Set the password used to move from the parameter setting screen to the maintenance mode. Arbitrary 4-digit number can be selected.

O2 ref. Value : Set the oxygen concentration reference value at the time of oxygen conversion calculation. Settable in the range from 00 to 19%.



Limit : Set the oxygen concentration limit at the time of oxygen conversion calculation. Settable in the range from 01 to 20%.

* Refer to the O2 conversion concentration value in “5.3 Outline of display screen” for oxygen conversion calculation procedure.



Station No. : Set the station No. for MODBUS communication. Settable in the range from 00 to 31.

Range setting : Set/change the measurement range.

| | |
|---|--------------|
| Maintenance Mode setting | Set password |
| Password Set 465 O2 ref. Value 12% O2 limit 20% O2 Station No. 01 Range setting | |

Press the  or the  key to move the cursor to the item whose setting is to be changed.

The values for password, oxygen conversion, limit, and station No. are highlighted.

Press the  or the  key to change the value to desired one, and then press the  key.

 **CAUTION**

Pay attention not to forget the password. Otherwise you cannot enter the maintenance mode.

<How to set/change the range>

The measuring range can be arbitrarily selected in the minimum and the maximum range specified at the time of purchase. The range to be used can be selected 1 or 2.

(1) Move the cursor to the item to be set by pressing the or the key, and then press the key.

(2) Move the cursor to the Ch (component) whose setting is to be changed by pressing the or the key, and then press the key.

(3) Move the cursor to the item whose setting is to be changed by pressing the or the key, and then press the key.

Settable range

The value for range 1 and range 2 must fall within the range from the MIN and the MAX range (including the MIN and the MAX range), and at the same time range 1 must be smaller than range 2.

The number of ranges is 1 or 2.

(4) Press the or the key to change the value.

Press the key to select the next digit. In a state where the decimal point is highlighted, press the or the key, and the decimal point position can be changed.

(5) When necessary change is made, press the key.

CAUTION

After changing the range setting, make sure to perform following procedure:

(1) Reset (OFF/ON) the power

(2) Calibrate zero point and span

The omission of power reset and calibration may cause abnormal measurement values.

| | |
|---|----------------|
| Maintenance Mode setting | Select an item |
| Password set 2465 O2 ref. Value 12% O2 limit 20% O2 Station No. 01 <input checked="" type="checkbox"/> Range setting | |



| | |
|---|---------------|
| Maintenance Mode Range set | Select Ch No. |
| <input checked="" type="checkbox"/> Ch1 NOx Ch2 SO2 Ch3 CO2 Ch4 CO Ch5 O2 | |



| | |
|--|----------------------------|
| Maintenance Mode Range Set Ch1 NOx | Select range or range num. |
| MIN range 100.0 ppm Range 1 500.0 ppm Range 2 1000. ppm <input checked="" type="checkbox"/> MAX range 2000. ppm Range num. 2 | |



| | |
|---|-----------|
| Maintenance Mode Range Set Ch1 NOx | Set range |
| MIN range 100.0 ppm Range 1 500.0 ppm Range 2 1000. ppm MAX range 2000. ppm Range num. 2 | |







Range setting, change end

6.9 Manual calibration procedure

6.9.1 Manual zero calibration

It is used for zero point adjustment. For zero calibration gas, suited for an application should be used according to “(3) Standard gas in Section 3.4 Sampling.”

- (1) Press the  key on the Measurement screen to display the Manual Zero Calibration screen.

- (2) Select the Ch (component) to be calibrated by pressing the  or  key. After selection, press the  key, and zero gas will be supplied.

CAUTION

- The analyzer simultaneously calibrate the zero point of all the channels (components) that have been set to “at once” in “6.2.2 setting of manual zero calibration”.
- The analyzer simultaneously calibrate the zero points of both ranges of the channels (components) set to “both” in “6.2.3 setting of calibration range”.

- (3) Wait until the indication is stabilized with the zero gas supplied. After the indication has been stabilized, press the  key. Zero calibration in range selected by the cursor is carried out.

Note: For the Ch (component) for which “AR” is selected in “6.1.1 Setting range switch mode,” the cursor automatically moves to the range selected in “Setting of auto calibration component/range” (6.2.4), and calibration is carried out within that range.

To close "Zero Calibration"

To close the “Zero Calibration” or cancel this mode midway, press the  key. A previous screen will return.

Measurement Mode



| | | |
|------------------------|--|-------|
| ZERO Cal. | Select Ch No. with UP / DOWN and ENT Back with ESC | |
| Ch1 NO _x | ▶Range1 0-100 ppm ▶Range2 0-2000 ppm | 0.0 |
| Ch2 SO ₂ | ▶Range1 0-100 ppm ▶Range2 0-2000 ppm | 0.0 |
| Ch3 CO ₂ | ▶Range1 0-10 vol% ▶Range2 0-20 vol% | 0.00 |
| Ch4 CO | ▶Range1 0-100 ppm ▶Range2 0-2000 ppm | 0.0 |
| Ch5 O ₂ | ▶Range1 0-10 vol% ▶Range2 0-25 vol% | 20.09 |



| | | |
|------------------------|--|-------|
| ZERO Cal. | Select Ch No. with UP / DOWN and ENT Back with ESC | |
| Ch1 NO _x | ▶Range1 0-100 ppm ▶Range2 0-2000 ppm | 0.0 |
| Ch2 SO ₂ | ▶Range1 0-100 ppm ▶Range2 0-2000 ppm | 0.0 |
| Ch3 CO ₂ | ▶Range1 0-10 vol% ▶Range2 0-20 vol% | 0.00 |
| Ch4 CO | ▶Range1 0-100 ppm ▶Range2 0-2000 ppm | 0.0 |
| Ch5 O ₂ | ▶Range1 0-10 vol% ▶Range2 0-25 vol% | 20.09 |



| | | |
|------------------------|---|-------|
| ZERO Cal. | ENT : Go on calibration of selected Ch. ESC : Not calibration | |
| Ch1 NO _x | ▶Range1 0-100 ppm ▶Range2 0-2000 ppm | 0.0 |
| Ch2 SO ₂ | ▶Range1 0-100 ppm ▶Range2 0-2000 ppm | 0.9 |
| Ch3 CO ₂ | ▶Range1 0-10 vol% ▶Range2 0-20 vol% | 0.34 |
| Ch4 CO | ▶Range1 0-100 ppm ▶Range2 0-2000 ppm | 1.1 |
| Ch5 O ₂ | ▶Range1 0-10 vol% ▶Range2 0-25 vol% | 20.09 |



To Measurement screen after executing Manual Zero Calibration

6.9.2 Manual span calibration



It is used to perform a span point adjustment. Supply calibration gas with concentration set to the span value to perform the span calibration. For the span calibration gas for the NO_x, SO₂, CO₂, CO measurement, use the standard gas with a concentration of between 90% and 100% of the range value. For the span calibration gas for the O₂ measurement, use the standard gas with a concentration of between 90% and 100% of the range value when measuring with the built-in O₂ sensor, and use the standard gas of about 2 vol% when measuring with an external zirconia O₂ sensor.

- (1) Press the  key on the Measurement screen to display the Manual Span Calibration screen.

Measurement Mode



| | | | |
|--|--|---|-------|
| SPAN Cal. | | Select Ch No. with UP / DOWN and ENT Back with ESC | |
| <input checked="" type="checkbox"/> Ch1 NO _x | ▶ Range1 0-100 ppm Range2 0-2000 ppm | | 0.0 |
| Ch2 SO ₂ | ▶ Range1 0-100 ppm Range2 0-2000 ppm | | 0.0 |
| Ch3 CO ₂ | ▶ Range1 0-10 vol% Range2 0-20 vol% | | 0.00 |
| Ch4 CO | ▶ Range1 0-100 ppm Range2 0-2000 ppm | | 0.0 |
| Ch5 O ₂ | ▶ Range1 0-10 vol% ▶ Range2 0-25 vol% | | 20.09 |

- (2) Select Ch (component) to be calibrated by pressing the  or  key and press the  key. The calibration gas is supplied.



| | | | |
|--|--|---|-------|
| SPAN Cal. | | Select Ch No. with UP / DOWN and ENT Back with ESC | |
| Ch1 NO _x | ▶ Range1 0-100 ppm Range2 0-2000 ppm | | 0.0 |
| <input checked="" type="checkbox"/> Ch2 SO ₂ | ▶ Range1 0-100 ppm Range2 0-2000 ppm | | 0.0 |
| Ch3 CO ₂ | ▶ Range1 0-10 vol% Range2 0-20 vol% | | 0.00 |
| Ch4 CO | ▶ Range1 0-100 ppm Range2 0-2000 ppm | | 0.0 |
| Ch5 O ₂ | ▶ Range1 0-10 vol% ▶ Range2 0-25 vol% | | 20.09 |

⚠ CAUTION
When “both” from “Calibration Range” of the Calibration Setting mode is set, span calibration is performed together with 2 Ranges.

- (3) Wait until the indication is stabilized in the state where the calibration gas is supplied. After the indication has been stabilized, press the  key. Span calibration of Range selected by the cursor is performed.



| | | | |
|------------------------|--|--|-------|
| SPAN Cal. | | ENT : Go on calibration of selected Ch. ESC : Not calibration | |
| Ch1 NO _x | ▶ Range1 0-100 ppm Range2 0-2000 ppm | <input checked="" type="checkbox"/> | 0.0 |
| Ch2 SO ₂ | ▶ Range1 0-100 ppm Range2 0-2000 ppm | <input checked="" type="checkbox"/> | 0.9 |
| Ch3 CO ₂ | ▶ Range1 0-10 vol% Range2 0-20 vol% | <input checked="" type="checkbox"/> | 0.34 |
| Ch4 CO | ▶ Range1 0-100 ppm Range2 0-2000 ppm | <input checked="" type="checkbox"/> | 1.1 |
| Ch5 O ₂ | ▶ Range1 0-10 vol% ▶ Range2 0-25 vol% | <input checked="" type="checkbox"/> | 20.09 |

⚠ CAUTION
For the Ch (component) for which “AR” is selected in “6.1.1 Setting range switch mode,” the cursor automatically moves to the range selected in “Setting of auto calibration component/range” (6.2.4), and calibration is carried out within that range.

To close "Span Calibration"
To close the “Span Calibration” or cancel this mode midway, press the  key. A previous screen will return.



To Measurement screen after executing Manual Span Calibration

7. MAINTENANCE

7.1 Daily check

(1) Zero calibration and span calibration

- (1) Perform zero calibration. For the calibration procedures, refer to “Section 6.9.1 Manual zero calibration.”
- (2) Then, perform span calibration. For the calibration procedures, refer to “Section 6.9.2 Manual span calibration.”
- (3) Zero calibration and span calibration should be carried out once a week, as required.

(2) Flow rate check

- (1) Sampling gas flow and purge gas flow are as follows:
 - Sampling gas flow: 0.5L/min±0.2L/min
 - Purge gas flow: About 1L/min
- (2) Check and maintenance should be carried out every day, as required.

7.2 Daily check and maintenance procedures

Table 7.1 Maintenance and check table

| | Parts to be checked | Phenomena | Causes | Remedy |
|--------------|--|---|--|---|
| Daily check | Indication value | Indication values are lowered. Indication values are higherd. | (1) Dust is mixed in sampling cell. | (1) Clean the sampling cell. In addition, check sampling devices, especially gas filter. |
| | | | (2) Air is absorbed midway in the sampling pipe. | (2) Find out cause of leak and repair. |
| | Sample gas flow rate (Flow rate of purging gas is included if purging is used) | Standard flow is beyond the specified flow rate of 0.5L/min, 0.3 to 0.7L/min. | _____ | Adjust by needle valve of flow rater. |
| Weekly check | Zero point of gas analyzer | It is deflected. | _____ | Adjust. |
| | Span point of gas analyzer | It is deflected. | _____ | Adjust. |
| Yearly check | Gas analyzer | Regardless of any phenomena | _____ | Overhaul. |

7.3 Maintenance of analyzer unit

⚠ CAUTION

Only adequately trained operator shall carry out the maintenance work described in 7.3.1 Cleaning method for sample cell (pipe cell), 7.3.2 Cleaning method for sample cell (block cell), 7.3.3 Optical zero adjustment method (optical balance adjustment), 7.3.4 Moisture interference compensation adjustment method.

The maintenance work that is not described in this section shall be carried out in accordance with rules or safety requirements specific to customer.

⚠ CAUTION

While the analyzer is in operation, the handle becomes a high temperature part. If you touch the handle for maintenance or other reasons, please wait 30 minutes or more of heat release time after turning off the power supply.

7.3.1 Cleaning method for sample cell (pipe cell)

This section is strictly factory adjusted. Handle it with utmost attention.

If it is absolutely required, contact us.

- (1) Turn off the power switch, stop the sample gas, and allow the zero gas to flow for several minutes to purge the cell interior.
Loosen the setscrew (3 pieces) from the top cover and remove it.
- (2) Remove the internal gas inlet tube.
- (3) Loosen both right and left screws for cell holding plate.
 - Remove the sample cell only.
- (4) Turn to the left the sample cell window and remove it from the sample cell (see Fig. 7-1).
- (5) For cleaning the window and cell inside surface, first eliminate coarse dust by soft brush or the like and then wipe them by soft rag.
The window is easy to get scratched. Pay utmost attention so as not to damage it.
- (6) After the end of sample cell cleaning, mount the cell in place and proceed to running.

After cleaning sample cell, be sure to perform optical zero adjustment (see Section 7.3.3) and moisture interference compensation adjustment (see Section 7.3.4).

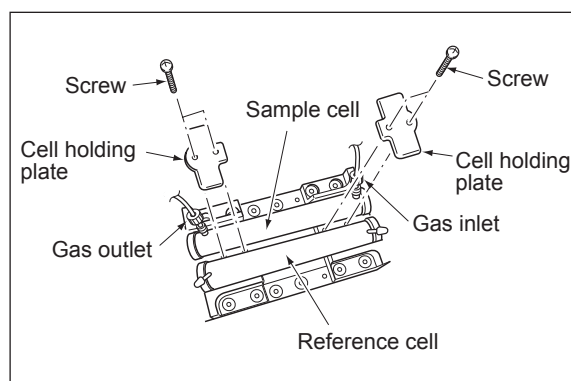
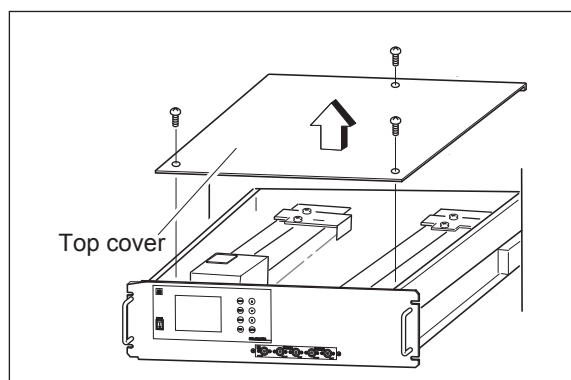

⚠ CAUTION

If the window or the cell interior is very dirty, use a soft cloth moistened with absolute alcohol. A slightly corroded infrared transmission window or sample cell can be remedied by gently rubbing with chromium oxide powder on cleaning cloth but an excessively corroded one must be replaced. When cleaning, do not exert an excessive stress.

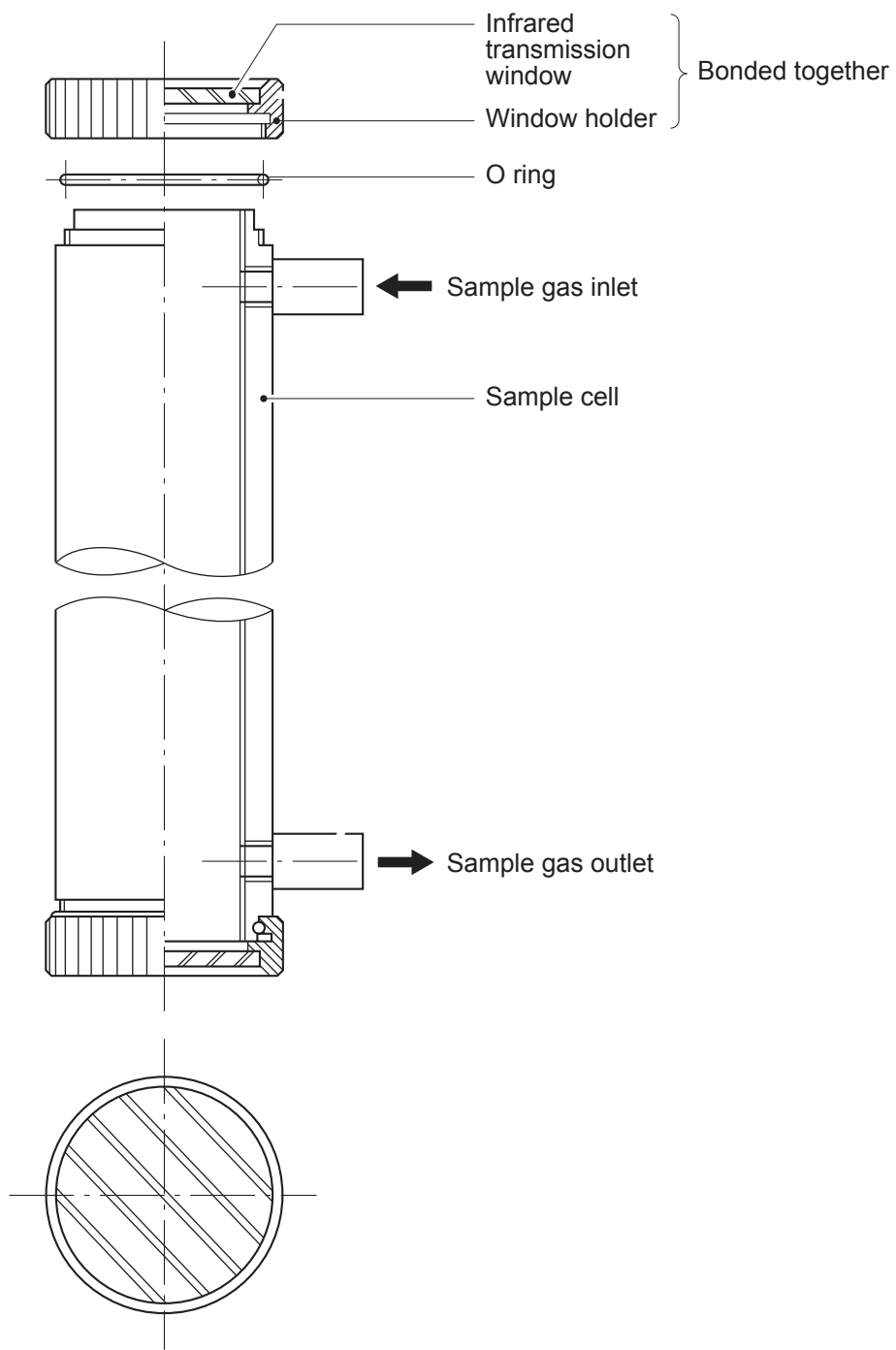

Fig. 7-1 Structure of sample cell (pipe cell)

7.3.2 Cleaning method for sample cell (block cell)

This section is strictly factory adjusted. Handle it with utmost attention.
If it is absolutely required, contact us.

- (1) Turn off the power switch, stop the sample gas, and allow the zero gas to flow for several minutes to purge the cell interior.

Loosen the setscrew (3 pieces) from the top cover and remove it.

- (2) Remove the internal gas inlet tube.
- (3) Loosen the 2 detector set bolts.

Note) The distribution cell, block cell and detector are fastened by the same bolts.

- (4) Using the furnished cell mounting tool, turn the window fixture to the left and remove it from the cell.

(See the structure of sample cell (block cell) in Fig. 7-2.)

- (5) For cleaning the infrared transmission window and cell inside surface, first eliminate coarse dust by soft brush or the like and then wipe them by soft rag. The window is easy to get scratched. Pay utmost attention so as not to damage it.

- (6) After the end of sample cell cleaning, mount the cell in place and proceed to running.

After cleaning sample cell, be sure to perform optical zero adjustment (see Section 7.3.3) and moisture interference compensation adjustment (see Section 7.3.4).

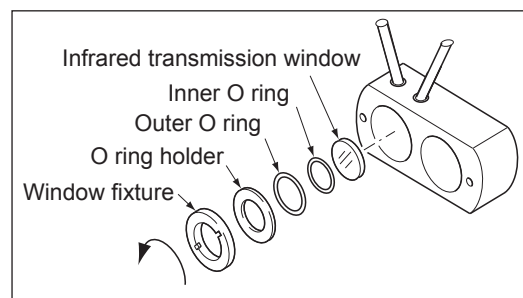
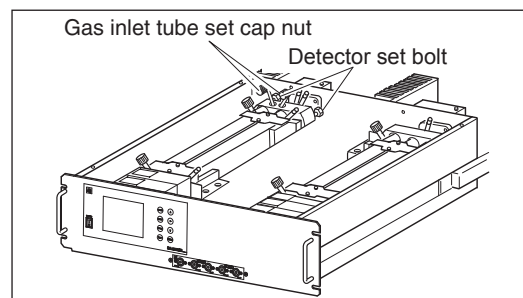
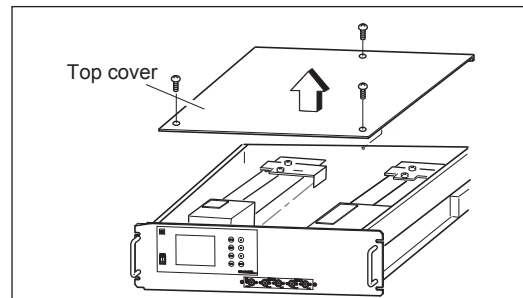

CAUTION

If the window or the cell interior is very dirty, use a soft cloth moistened with absolute alcohol. A slightly corroded infrared transmission window or sample cell can be remedied by gently rubbing with chromium oxide powder on cleaning cloth but an excessively corroded one must be replaced. When cleaning, do not exert an excessive stress.

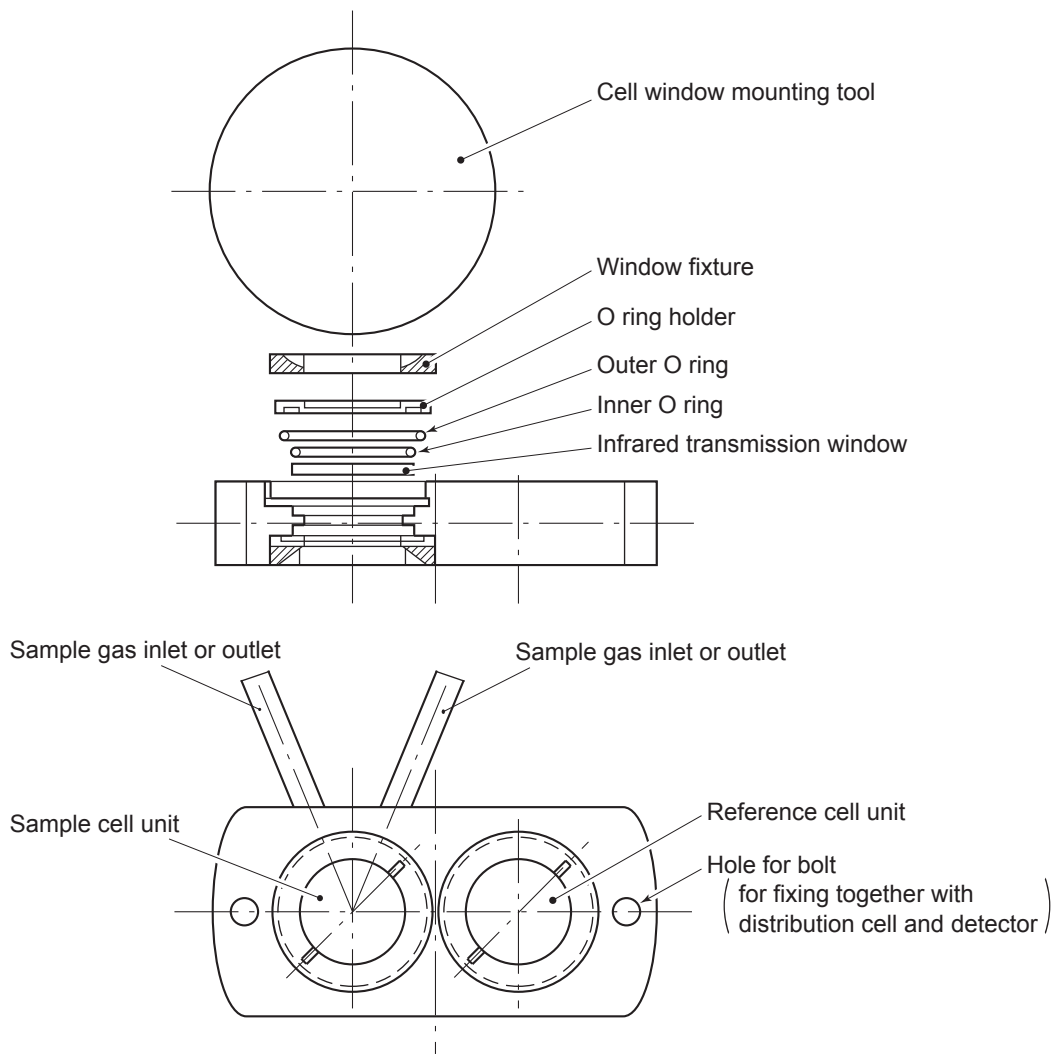

Structure of sample cell (of 32, 16, 8, 4, 2 mm long)
 (sample cell and reference cell are integrated)

Note) Use the dedicated cell window mounting tool (furnished).

Fig. 7-2 Structure of sample cell (block cell)

7.3.3 Optical zero adjustment method (optical balance adjustment)

CAUTION

If the following operation is maladjusted, the measurement may adversely be affected. If you are not trained for adjustment, do not carry out this operation but contact the distributor or our service-man.

The adjustment is performed at reassembly after removing the sample cell, etc. for cleaning, etc.

- (1) Remove the top cover. Allow dry N₂ or air to flow through the analyzer unit sample gas inlet until the reading stabilizes. The sample gas is introduced directly to the INLET of analyzer unit through the gas cylinder.
- (2) Proceed to an optical adjustment in the maintenance mode. The display on the operation panel of the main unit is as illustrated on the right. Balance adjustment is not required if the display falls within ± 100 .

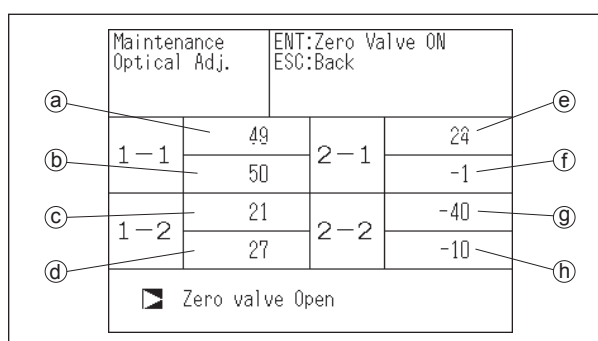
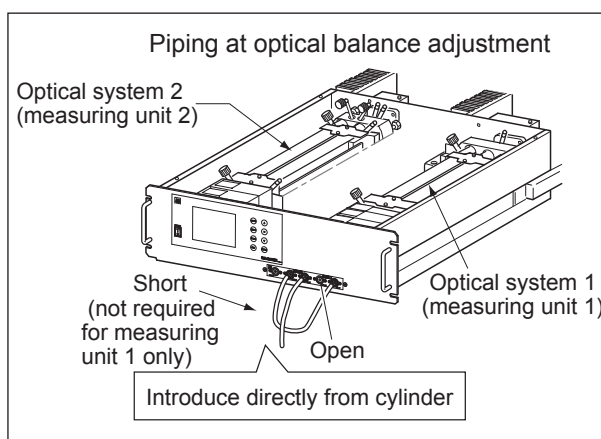

<Correspondence between measurement detector and indicated position>

| No. of components to be measured | (a) | (b) | (c) | (d) | (e) | (f) | (g) | (h) |
|----------------------------------|--|-----------------------|-----------------------|----------------------|----------------------|-----------------------|-----------------------|----------------------|
| 1-component analyzer | Main | Comp | - | - | - | - | - | - |
| 2-component analyzer | NO/SO ₂ | NO Main | NO Comp | SO ₂ Main | SO ₂ Comp | - | - | - |
| | CO ₂ /CO | CO ₂ Main | CO ₂ Comp | CO Main | CO Comp | - | - | - |
| | NO/CO | NO Main | NO Comp | - | - | CO Main | CO Comp | - |
| | N ₂ O/CO ₂ | N ₂ O Main | N ₂ O Comp | CO ₂ Main | - | - | - | - |
| 3-component analyzer | NO/SO ₂ /CO | NO Main | NO Comp | SO ₂ Main | SO ₂ Comp | CO Main | CO Comp | - |
| | NO/N ₂ O/CO ₂ | NO Main | NO Comp | - | - | N ₂ O Main | N ₂ O Comp | CO ₂ Main |
| | SO ₂ /N ₂ O/CO ₂ | SO ₂ Main | SO ₂ Comp | - | - | N ₂ O Main | N ₂ O Comp | CO ₂ Main |
| | N ₂ O/CO ₂ /CO | N ₂ O Main | N ₂ O Comp | CO ₂ Main | - | CO Main | CO Comp | - |
| | CH ₄ /N ₂ O/CO ₂ | CH ₄ Main | CH ₄ Comp | - | - | N ₂ O Main | N ₂ O Comp | CO ₂ Main |
| 4-component analyzer | NO/SO ₂ /CO ₂ /CO | NO Main | NO Comp | SO ₂ Main | SO ₂ Comp | CO ₂ Main | - | CO Main |
| | NO/SO ₂ /N ₂ O/CO ₂ | NO Main | NO Comp | SO ₂ Main | SO ₂ Comp | N ₂ O Main | N ₂ O Comp | CO ₂ Main |

* O₂ is excluded from the number of components.

* "Main" is signal input value from the main detector of each component.

"Comp" is signal input value from interference compensation detector of each component.

If low range exceeds the range of 0 to 10vol%, detector signal of "comp" is not usable.

Sensor values of which are not included in measuring components should be ignored.

- (3) Carry out the adjustment in the procedure in (4) and subsequent.
- Adjust on the primary side of the optical system so that the values for (a) to (d) in 1-1 and 1-2 become as close to 0 as possible within ± 100 range.
 - Adjust on the secondary side of the optical system so that the values for (e) to (h) in 2-1 and 2-2 become as close to 0 as possible within ± 100 range.

- (4) Operate the optical zero adjustment knob to change the value displayed at (a) (or (e)).
- (5) Move the beam adjustment plate sideview to change the value displayed at (b) (or (f)).
- (6) Move the beam adjustment plate side-wise to change the value displayed at (c) (or (g)).
- (7) Move the beam adjustment plate side-wise to change the value displayed at (d) (or (h)).
- (8) Repeat the procedures in (4) to (7) to make all the displayed values come close to 0 as possible within ± 100 range.

*** Adjust the beam adjustment plate which is the nearest to the zero adjustment knob first, and sequentially.**

- (9) After the optical balance adjustment, mount the top cover of the analyzer unit, then carry out a moisture interference compensation adjustment, and perform zero and span calibrations.

*** Before moving the beam adjustment plate, loosen the detector set bolts (just enough to make the plate movable for snug adjustment).**

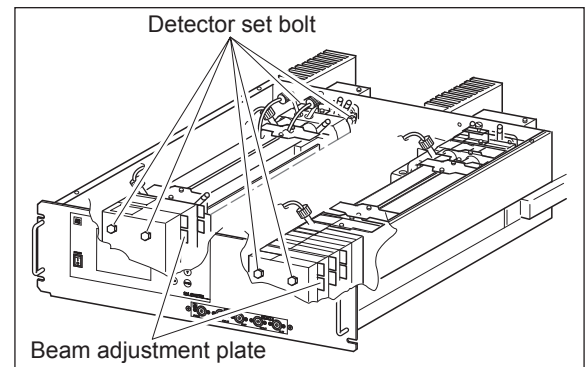
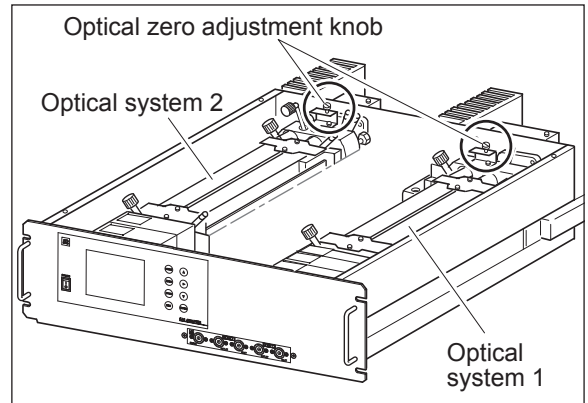

7.3.4 Moisture interference compensation adjustment method

⚠ CAUTION



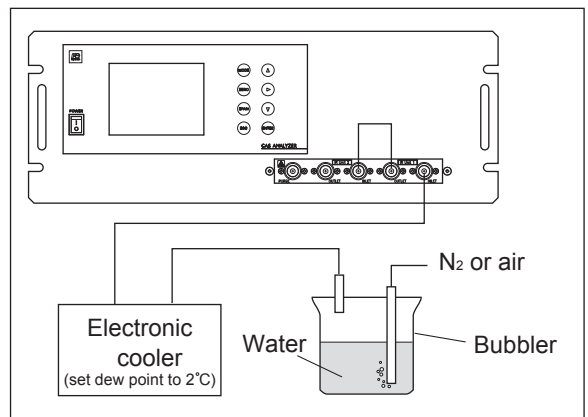

If the following operation is maladjusted, the measurement may adversely be affected. If you are not trained for adjustment, do not carry out this operation but contact the distributor or our service-man.

Proceed to an adjustment if excessively (beyond $\pm 2\%$ FS) affected by moisture interference. After the end of optical balance adjustment, be sure to carry out moisture interference compensation adjustment.

- (1) After warm-up, select the low range, allow dry gas (N_2 , air) to flow at 0.5 L/min and carry out zero calibration.



(2) Display the moisture interference compensation screen of the analyzer unit (see “6.8 Maintenance mode”). Set the dew point to 2°C by using an electronic cooler, and introduce bubbled N₂ or air gas to the analyzer (shown on the figure).

(3) On the screen, select a desired Ch (component) by pressing the  key, adjust the value at right by pressing the  or the  key so that the value at left falls within ±10 (make it as close to 0 as possible), and then press the  key to fix the value. (Exiting by “” cancels the adjustment.)

Or, selecting the “ALL” and pressing the  key, zeroes all Ch (components) integrally.

(First, adjust all Ch (components) by selecting ALL and then perform fine adjustment for Ch (components) one by one using UP and DOWN keys.)

* If any Ch (components) exceed the range of 0 to 10vol%, no adjustment can be performed (No interference compensation is required).

| Moisture interference Compensation Adj. | | Select Ch No. with UP / DOWN and ENT Back with ESC | |
|---|-----------------|---|-------|
|  Ch1 | NO _x | 10 | 1.252 |
| Ch2 | SO ₂ | -33 | 0.983 |
| Ch3 | CO ₂ | 13 | 0.000 |
| Ch4 | CO | 20 | 1.922 |
| ALL | | | |
| Valve OFF | | | |



| Moisture interference Compensation Adj. | | Adjust with UP / DOWN ENT : Memorized ESC : Back | |
|---|-----------------|--|-------|
| Ch1 | NO _x | 10 | 1.252 |
| Ch2 | SO ₂ | -33 | 0.983 |
| Ch3 | CO ₂ | 13 | 0.000 |
| Ch4 | CO | 20 | 1.922 |
| ALL | | | |
| Valve OFF | | | |

(4) After the end of adjustment for all Ch (components), return the piping to the original status and carry out zero and span calibrations.

7.4 Long term maintenance

Create a long-term maintenance component procurement plan based on the “Gas analyzer annual inspection plan” indicated below.

Gas analyzer annual inspection plan

The recommended replacement period of components varies depending on the installation conditions.

- 1) The recommended replacement period is a recommended standard criterion, and varies depending on the environment of the field, conditions of measuring gas and other factors.
- 2) The recommended replacement period is not the warranty period. It is provided as a preventative maintenance program baseline schedule.

- Installation conditions

- 1) Ambient temperature: -5°C to $+40^{\circ}\text{C}$
- 2) Humidity: 90%RH or less
- 3) Corrosive gases: None
- 4) No radiated heat, direct sunlight or rain/wind
- 5) Dust: No more than local environmental standards permit
- 6) Vibration: None

- Sample gas conditions

- 1) Flow rate: $0.5 \pm 0.2\text{L} / \text{min}$
- 2) Temperature: 0 to 50°C
- 3) Dust: $100 \mu\text{g}/\text{Nm}^3$ or less in particle size of $0.3 \mu\text{m}$ or smaller
- 4) Mist: Unallowable
- 5) Moisture: For sample gases NO, SO₂, CO (smaller than 0-200 ppm range): less than 2°C saturation point.

For most other sample gases: less than standard room temperature saturation point.

Please consult with us regarding gas analyzer maintenance service requirements.

We may assist in providing access and support via a qualified service network.

Infrared gas analyzer annual inspection plan sheet

| Component name | Q'ty | Recommended replacement period (year) | Year | | | | | | | | | | |
|--|--------|---------------------------------------|----------------|----------|----------|----------|----------|----------|----------|----------|----------|----------|-----------|
| | | | Delivered year | 1st year | 2nd year | 3rd year | 4th year | 5th year | 6th year | 7th year | 8th year | 9th year | 10th year |
| Infrared light source | 1 or 2 | 5 | | | | | | ○ | | | | | ○ |
| Sampling cell and Reference cell (only for 250mm) | 2 or 4 | 3 | | | | ○ | | | ○ | | | ○ | |
| Sampling cell and Reference cell (less than 125mm) | 2 or 4 | 5 | | | | | | ○ | | | | | ○ |
| Distributing cell | 1 or 2 | 5 | | | | | | ○ | | | | | ○ |
| O-ring for sampling cell and reference cell | 1 to 6 | 2 | | | ○ | | ○ | | ○ | | ○ | | ○ |
| Vibration absorbing sheet for optical parts | 2 or 4 | 2 | | | ○ | | ○ | | ○ | | ○ | | ○ |
| Ineterference gas filter cell | 1 or 2 | 5 | | | | | | ○ | | | | | ○ |
| Detector unit (Main and Comp) | 1 to 4 | 5 | | | | | | ○ | | | | | ○ |
| Sector motor and Driver unit | 1 or 2 | 3 | | | | ○ | | | ○ | | | ○ | |
| AC/DC Power supply (MTW) | 1 | 3 | | | | ○ | | | ○ | | | ○ | |
| AC/DC Power supply (PBA) | 1 | 6 | | | | | | | ○ | | | | |
| LCD unit | 1 | 3 | | | | ○ | | | ○ | | | ○ | |
| Gas analyzer main unit | 1 | 10 | | | | | | | ○ | | | | ○ |
| Expenses for overhaul of gas analyzer unit at our shop | | 5 | | | | | | ○ | | | | | ○ |
| Expenses for annual inspection | | 1 | ○ | ○ | ○ | ○ | ○ | ○ | ○ | ○ | ○ | ○ | ○ |

7.5 Replacement of fuse

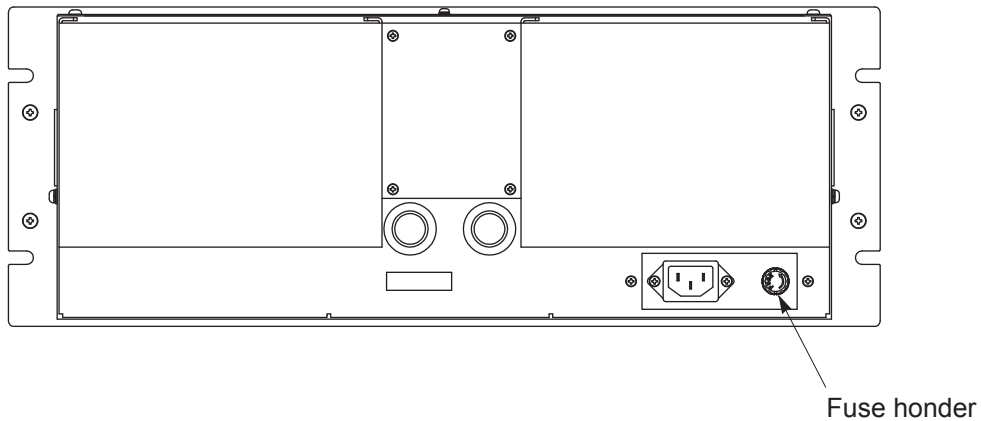

Note) Prior to the following work, be sure to repair blown down fuse (short, etc), if any.

- (1) Turn "OFF" the main power supply switch to the analyzer.
- (2) Turn the fuse holder cap (shown in the figure above) counterclockwise and pull it out, and the cap will be removed. Remove a fuse out of the holder. Replace it with a new one. (250 V. T. 3.15A. L).
- (3) Reinstall the fuse holder cap, turn ON the power supply switch. The work will be completed if the analyzer starts up normally.

8. ERROR MESSAGE

If errors occur, the following contents are displayed.

| Error display | Error contents | Probable causes |
|---------------|--|--|
| Error No.1 | Motor rotation detection signal faulty | <ul style="list-style-type: none"> • Motor rotation is faulty or stopped. • Motor rotation detector circuit is faulty. Note) Sector motor is a consumption part. It is recommendable to exchange the motor once two years. |
| Error No.4 | Zero calibration is not within. | <ul style="list-style-type: none"> • Zero gas is not supplied. • Zero is deflected much due to dirty cell. • Detector is faulty. • Optical balance is maladjusted. |
| Error No.5 | Amount of zero calibration (indication value) is over 50% of full scale. | |
| Error No.6 | Span calibration is not within the allowable range. | <ul style="list-style-type: none"> • Span gas is not supplied. • Calibrated concentration setting does not match cylinder concentration. • Zero calibration is not performed normally. • Span is deflected much due to dirty cell. • Detector sensitivity has deteriorated. |
| Error No.7 | Amount of span calibration (difference between indication value and calibrated concentration) is over 50% of full scale. | |
| Error No.8 | Measured values fluctuate too much during zero and span calibration. | <ul style="list-style-type: none"> • Calibration gas is not supplied. • Time for flowing calibration gas is short. |
| Error No.9 | Calibration is abnormal during auto calibration. | <ul style="list-style-type: none"> • Error corresponding to No. 4 to No. 8 occurred during auto calibration. |
| Error No.10 | Output cable connection is improper. | <ul style="list-style-type: none"> • Wiring is detached between analyzer and I/O terminal module. • Wiring is disconnected between analyzer and I/O terminal module. |

When errors No. 1 and No. 10 occur, analyzing block error contact output is closed.

When errors No. 4 to No. 9 occurs, calibration error contact output is closed.

Screen display and operation at the occurrence of error

In case of Error No. 1 to No. 4, No. 6, No. 8 to No. 10

Measurement screen

| | | |
|----|-------------------|------------|
| g | Error No.9 | 00.8 ppm |
| ch | 2 SO ₂ | 13.6 ppm |
| ch | 3 CO ₂ | 0.000 vol% |
| ch | 4 CO | 0.0 ppm |
| ch | 5 O ₂ | 21.00 vol% |

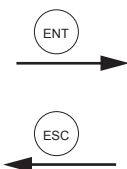

Display of error contents

| | |
|---|--------------------------------------|
| Error No.9 | Auto Cal. error ESC:Back to MEAS. |
| SPAN NOX Calibration error Cause | |
| <ul style="list-style-type: none"> • Calibration gas is not flowing • Gas flowing time is short • Setting conc. is different from gas conc. • Dirt in sample cell | |

- Press the **ESC** key to delete the error display.
- If the **ESC** key is pressed without removing the cause of an error, the error will be displayed again.
- If you hear abnormal sound from the motor and also the error No. 1 is displayed, the error No.1 disappears by power-cycling the gas analyzer.

- When more than one error occurs, pressing the **▶** key moves to another error display.

In case of Error No. 5 and No. 7

| | | | |
|------------------------|---------------------------------|---|--------|
| ZERO cal. | | ENT:Go on calibration of selected CH ESC:Not calibration | |
| Ch1 NO _x | ▶ Error No. 5 | ppm ppm | 3083 |
| Ch2 SO ₂ | ▶ Range1 0-100 Range2 0-2000 | ppm ppm | -13.6 |
| Ch3 CO ₂ | ▶ Range1 0-10 Range2 0-20 | vol% vol% | -0.006 |
| Ch4 CO | ▶ Range1 0-100 Range2 0-2000 | ppm ppm | 0.2 |
| Ch5 O ₂ | ▶ Range1 0-10 Range2 0-25 | vol% vol% | -0.09 |

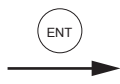

| | |
|--|--|
| Error No. 5 | SPAN cal. error ENT:Force Cal. ESC:Stop cal. and back to MEAS. |
| NO _x Calibration error Cause | |
| <ul style="list-style-type: none"> • Span gas is not flowing • Deviation of zero point due to contamination • Low sensitivity of detector | |

- Pressing **ESC** delete the error display.

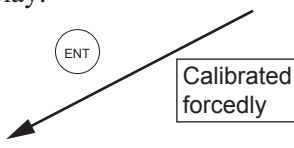

Calibration is continued. Unless another calibration error occurs, calibration is carried out to the end, the Measurement screen returns.



| | | |
|------|--------------------------|------------|
| Ch 1 | NO ₂ 0-25 | 90.8 ppm |
| Ch 2 | SO ₂ 0-100 | 13.6 ppm |
| Ch 3 | CO ₂ 0-10 | 0.000 vol% |
| Ch 4 | CO 0-100 | 0.0 ppm |
| Ch 5 | O ₂ 0-25 | 0.09 vol% |

Error log file

If error occurs, the history is saved in an error log file. The error log file exists in the maintenance mode.

Error log screen

| | | | | | | |
|---|----|----------------------------------|----|----|----|--------|
| Maintenance Error Log | | ENT: Clear Error Log ESC:Back | | | | |
| errorNo. | YY | MM | DD | HH | MM | Ch |
| No. 10 | 17 | 9 | 27 | 22 | 24 | |
| No. 10 | 17 | 9 | 21 | 19 | 1 | |
| No. 10 | 17 | 9 | 21 | 19 | 0 | |
| No. 10 | 17 | 9 | 21 | 14 | 46 | |
| No. 7 | 17 | 9 | 19 | 14 | 10 | 5 |
| No. 10 | 17 | 9 | 19 | 11 | 28 | |
| No. 1 | 17 | 9 | 14 | 16 | 43 | OPT1 |
| ▼ Next page | | | | | | Page 1 |
| <input checked="" type="checkbox"/> Clear Error Log | | | | | | |

Date and time when an error occurred. (points to HH, MM)
 Component with which the error occurred. (points to Ch)
 New ↑
 ↓ Old

Errors that occurred (points to the list of error records)

* Up to 14 errors can be saved in the error history; the oldest error will be deleted one by one every time a new occurs.

* If the power supply is turned OFF, the contents in the error log file will not be lost or damaged.

Deletion of error history

Press the **ENT** key on the above screen, and the “Error Log Clear” will be inverted. Further pressing the **ENT** key will clear the error history.

9. SPECIFICATIONS

9.1 General specifications

SPECIFICATIONS

Standard Specifications

Measurement principle:

NO, SO₂, CO₂, CO, CH₄, N₂O:

Non-dispersive infrared (NDIR) method,
Single light source and double beams (double-beam system)

O₂:

Built-in paramagnetic O₂ sensor or external zirconia O₂ analyzer

Measurable gas components and measuring range:

| | Minimum range | Maximum range |
|------------------------------------|---------------|---------------|
| NO | 0–50 ppm | 0–5000 ppm |
| SO ₂ | 0–50 ppm | 0–10 vol% |
| CO ₂ | 0–20 ppm | 0–100 vol% |
| CO | 0–50 ppm | 0–100 vol% |
| CH ₄ | 0–200 ppm | 0–100 vol% |
| N ₂ O | 0–200 ppm | 0–2000 ppm |
| O ₂ (built in) | 0–5 vol% | 0–25 vol% |
| O ₂ (External Zirconia) | 0–5 vol% | 0–25 vol% |

- Max. 5 components measurement including O₂.
- Measuring range ratio ≤ 1:5 (O₂)
≤ 1:25 (except for O₂)
- Measuring ranges are changeable between the specified minimum and maximum range.
Settable 1 range or 2 ranges.
- If you measure N₂O only, do not let any other components be included in the sample gas.
If you measure multiple components including N₂O, the measurement ranges of N₂O are fixed to 0–200 ppm and 0–500 ppm. If the measuring objects are N₂O and CO₂, the measurement ranges of CO₂ are fixed to 0–10% and 0–20%.
- * For measurable components and possible combinations of measuring ranges, refer to Section 9.3 (1) - (8).

Measured value indication:

Digital indication in 4 digits (LCD with LED back light)

- Instantaneous value of each component
- Instantaneous value after O₂ conversion (only in NO, SO₂, CO measurement with O₂)
- Average value after O₂ conversion (only in NO, SO₂, CO measurement with O₂)
- O₂ average value

Analog output signals:

* Inputs/outputs of analog signals are possible by combining with the input/output terminal module.

4 to 20mA DC or 0 to 1V DC, isolated internally from circuit and ground. Output lines are non-isolated each other; 12 points max.

max.load 550Ω for 4 to 20 mA DC

min.load 100kΩ for 0 to 1V DC

* Refer to 5.3 (3) Contents of measured channel (Ch) for channel allocation for each component.

Analog input signal:

Signal from external O₂ analyzer;

(1) Signal from Fuji zirconia O₂ analyzer (ZFK7)

(2) 0 to 1 V DC full-scale signal

- Input section is no isolated.
- External O₂ analyzer is a separate order item.

Relay contact output:

1a contact (250V AC/2A, resistive load)

Instrument error, calibration error, range identification, auto calibration status, pump ON/OFF, peak alarm.

1c contact (250V AC/2A, resistive load selectable 6 outputs)

High/Low limit alarm contact output.

Power disconnection alarm.

* All relay contacts are isolated mutually and from the internal circuit.

Contact input:

No-voltage contact (ON/0V, OFF/5V DC, 5mA flowing at ON)

Remote range switch, auto calibration remote start, remote holding, average value resetting, pump ON/OFF
Isolated from the internal circuit with photocoupler.
Contact inputs are not isolated from one another.

Transmission output:

Solenoid valve drive signal for automatic calibration.

Transistor output (100mA or less)

Power supply:

Voltage rating; 100V to 240V AC

Allowable range; 85V to 264V AC

Frequency ; 50Hz/60Hz

Power consumption; 250VA max.

Inlet; Conform to EN60320, Protection Class 1

Operating conditions:

Ambient temperature; -5°C to 45°C

Ambient humidity; 90% RH max., non-condensing

Storage conditions:

Ambient temperature; -20°C to 60°C

Ambient humidity; 90% RH max., non-condensing

Dimensions (H x W x D):

Analyzer main unit; 177 × 483 × 599mm

Input/output terminal module; 164 × 316 × 55mm

Mass:

Approx. 22 kg (only Analyzer)

Finish color:

Front panel; Light gray (Munsell N7.2 or equivalent)

Casing; Plating, Steel-blue (gray)

Enclosure:

Steel casing, for indoor use

Material of gas-contacting parts:

Gas inlet/outlet/purging; SUS304 or resin

Sample cell; SUS304, chloroprene rubber

Infrared-ray transmitting window; CaF₂

O₂ sensor sample cell : SUS316

Internal piping; vinyl chloride, PTFE, Polypropylene

Gas inlet/outlet:

Rc1/4 or NPT1/4 internal thread

Purge gas flow rate:

1L/min (when required)

Standard Functions

Output signal holding:

Enables you to hold the output signal during calibration to the value right before the calibration is started or the user-specified value. Values indicated on LCD will not be held.

Remote output holding:

Applying the specified voltage on the dedicated terminal allows you to hold the output signal to the last value or the user-specified value. Holding is effective while the voltage is applied. Values indicated on LCD are not held.

Range changeover:

You can change between ranges by manually, automatically, or remotely.

Manual: by key operation

Auto: When the measured value reaches above 90% FS of the 1st range, the range automatically switches to the 2nd range. When the measured value goes down below 80% FS of the 1st range, the range automatically switches from the 2nd range to the 1st range.

Remote: by the no-voltage contact input. When the remote range changeover input terminal dedicated for each component is closed, the 1st range is effective. When the terminal is opened, the 2nd range becomes effective.

Range identification signal:

You can check which range is in use. When the 1st range is used, the range identification signal output terminal allocated for each component is closed. When the 2nd range is used, the terminal is opened.

Auto calibration:

This function requires standard gas cylinders for zero and span calibration and solenoid valves for opening/closing the gas flow line. When this function is activated, the analyzer opens and closes the solenoid valve driving contact periodically at preset cycle.

Auto calibration cycle setting:

1 hour to 99 hours (in increments of 1 hour) or 1 day to 40 days (in increments of 1 day).

Gas flow time setting:

The time during which calibration gas is supplied.
60 seconds to 900 seconds (in increments of 1 second)

Auto calibration remote start:

You can start one-time auto calibration if you open the auto calibration remote start input terminal for 1.5 seconds or longer and then close it. Calibration gas is drawn for the time set in the "gas flow time setting" for Auto calibration (see the previous item).

Auto zero calibration:

This function requires a standard gas cylinder for zero calibration and a solenoid valve for opening/closing the gas flow line. When this function is activated, the analyzer opens and closes the solenoid valve driving contact periodically at preset cycle. The cycle for the auto zero calibration and that for the auto calibration can be different.

Auto zero calibration cycle setting:

1 hour to 99 hours (in increments of 1 hour) or 1 day to 40 days (in increments of 1 day).

Gas flow time setting:

The time during which calibration gas is supplied
60 seconds to 900 seconds (in increments of 1 second)

High/low limit alarm:

When a measured value has gone beyond the upper limit or below the lower limit, the analyzer closes the contact to emit an alarm signal.

Instrument error contact output:

The contact is closed when an analyzer error (error No. 1 or 10) occurs.

Calibration error contact output:

The contact is closed if a calibration error (error No. 4, 5, 6, 7, or 9) occurs.

Auto calibration status contact output:

The contact is closed during auto calibration.

Pump ON/OFF contact output:

The contact is closed during measurement, and opened during calibration so that the sample gas flow is stopped during calibration

Optional Functions

O₂ conversion:

Conversion of measured NO, CO, and SO₂ gas concentrations into values at reference O₂ concentration

$$\text{Conversion formula: } C = \frac{21 - O_n}{21 - O_s} \times C_s$$

C: Sample gas concentration after O₂ conversion

C_s: Measured concentration of sample gas

O_s: Measured O₂ concentration (limit configurable within 1–20%)

O_n: Reference O₂ concentration (configurable within 0–19%)

Average value after O₂ conversion and O₂ average value calculation:

The analyzer can take measurement every 30 seconds, and calculate the moving average of:

- the instantaneous concentrations after O₂ correction or
- the instantaneous O₂ concentrations.

You can set the period for averaging in the range of 1–59 min (in one-minute increment) or 1–4 hour (in one-hour increment).

The analyzer transmits the moving average output every 30 seconds.

Average value resetting:

You can reset the average values by short-circuiting the average value resetting input terminal for 1.5 seconds or longer. You can start averaging over by opening it.

CO concentration peak count alarm:

(available option only for CO and O₂ analyzer)

The analyzer counts the number of times that the CO instantaneous value has reached the concentration limit you set. When the count per hour has reached the limit you set, the alarm is triggered.

Communication function:

RS-232C

9-pin D-sub connector

Half-duplex bit serial, Start-stop synchronization

Modbus RTU™ protocol

The communication function allows the analyzer to read and write parameters, and read measured concentration values and instrument status.

For connection to RS-485 interface, an RS232C–RS485 converter is required.

Performance

Repeatability:

±0.5% of full scale

±1% of full scale (for ranges below 0–50 ppm)

Linearity:

±1% of full scale

Zero drift:

- ±1% of full scale per week
- ±2% of full scale per week (for ranges between 0–50 ppm and 0–200 ppm)
- ±2% of full scale per day (for ranges below 0–50 ppm)

Span drift:

- ±2% of full scale per week
- ±2% of full scale per day (for ranges below 0–50 ppm)

Response time for 90% FS response:

- 15 seconds electrical response
- Response time when the gas flow rate is 0.5 L/min is within 60 seconds including replacement time of sample gas.
- Gas replacement time depends on the number of measuring components and range.

EU Directive Compliance **LVD:**

- EN 61010-1
- EN 62311

EMC:

- EN 61326-1 (Table 2)
- EN 61000-3-2 (Class A)
- EN 61000-3-3
- EN 61326-2-3

RoHS:

- EN IEC63000

Standard Requirements for Sample Gas**Flow rate:**

0.5L / min ±0.2L / min

Temperature:

0 to 50°C

Pressure:

10 kPa or less (Gas outlet should be opened to the atmospheric air.)

Dust:

100 µg/Nm³ or less in particle size of 0.3 µm or less

Mist:

Unallowable

Moisture:

Below a level where saturation occurs at 2°C (condensation unallowable).

Corrosive component:

1 ppm or less

Standard gas for calibration:

Zero gas: Dry N₂

Span gas: a component same as the measuring target, having concentration of 90–100% of its measuring range (recommended). Gas beyond a concentration of 100% FS is unusable.

In the case where an external zirconia O₂ analyzer is installed and calibration is carried out on the same calibration gas line as the other components:

Zero gas; Dry air or atmospheric air (Atmospheric air is not allowed if your measuring target includes CO₂.)

Span gas; For other than O₂ measurement, use a gas that has concentration of 90–100% of its measuring range. For O₂ measurement, use 1–2 vol% O₂.

Installation Requirements

- Indoor use. Select a place where the analyzer does not receive direct sunshine, wind and rain, or radiation from hot substances. If such a place cannot be found, a roof or cover should be prepared for protection.
- Avoid a place where the analyzer receives heavy vibration.
- Select a place where atmospheric air is clean.
- Discharge the exhaust gas to the safe place to the atmosphere.
- Do not use the analyzer in hazardous area.
- Altitude: up to 2187 yards (2000 m)

9.2 Code symbols

Basic type: ZKJ □□□□ 6- □□□□□□ - □□□□□□ - □□□□

| Digit | Description | note | 1 | 2 | 3 | 4 | 5 | 6 | 7 | 8 | 9 | 10 | 11 | 12 | 13 | 14 | 15 | 16 | 17 | 18 | 19 | 20 | 21 | 22 | 23 |
|-------|---|--|---|---|---|---|---|---|---|---|---|----|----|----|----|----|----|----|----|----|----|----|----|----|----|
| 4 | <Custom specifications> Standard | | Z | K | J | F | | | | 6 | | | | | | | | | | | | | | | |
| 5 | <Measurable component (SO ₂ , CO ₂ , CO, CH ₄ , N ₂ O) > 1st componet 2nd componet 3rd componet 4th componet | | | | | | | | | | | | | | | | | | | | | | | | |
| | NO SO ₂ CO ₂ CO CH ₄ | | | | | | | | | | | | | | | | | | | | | | | | |
| | NO NO CO ₂ NO NO | SO ₂ CO CO SO ₂ SO ₂ | | | | | | | | | | | | | | | | | | | | | | | |
| | N ₂ O N ₂ O NO SO ₂ N ₂ O CH ₄ NO | CO ₂ N ₂ O N ₂ O CO ₂ CO ₂ N ₂ O SO ₂ | | | | | | | | | | | | | | | | | | | | | | | |
| | | | | | | | | | | | | | | | | | | | | | | | | | |
| 6 | <Measurable component (O ₂)> None External zirconia type O ₂ sensor (Model : ZFK7) External O ₂ analyzer Built-in paramagnetic type O ₂ sensor | note 1b) note 1a)b) | | | | | | | | | | | | | | | | | | | | | | | |
| | | | | | | | | | | | | | | | | | | | | | | | | | |
| 7 | <Gas inlet/outlet> Rc ¹ / ₄ Rc ¹ / ₄ , with purging NPT ¹ / ₄ NPT ¹ / ₄ , with purging Resin(ø6) | note 2 note 2 note 2 | | | | | | | | | | | | | | | | | | | | | | | |
| | | | | | | | | | | | | | | | | | | | | | | | | | |
| 8 | <Revision code> | | | | | | | | | | | | | | | | | | | | | | | | |
| 9 | <Accessories> None With relay board for auto calibration, with cable With slide rail With slide rail, relay board, and cable | | | | | | | | | | | | | | | | | | | | | | | | |
| | | | | | | | | | | | | | | | | | | | | | | | | | |
| 10 | <Indication and power cord> Japanese, Power cord rated 125V (UL/CSA/PSE) English, Power cord rated 125V (UL/CSA/PSE) English, Power cord rated 250V (ENEC) Chinese, Power cord rated 250V (CCC) | note 3 | | | | | | | | | | | | | | | | | | | | | | | |
| | | | | | | | | | | | | | | | | | | | | | | | | | |
| 11 | <Measuring range> 1st component | note 4 | | | | | | | | | | | | | | | | | | | | | | | |
| 12 | Minimum range Maximum range | note 5 | | | | | | | | | | | | | | | | | | | | | | | |
| | 0 to 20ppm 0 to 50ppm 0 to 100ppm 0 to 200ppm 0 to 200ppm 0 to 200ppm 0 to 200ppm | 0 to 500ppm 0 to 1000ppm 0 to 2000ppm 0 to 500ppm 0 to 2000ppm 0 to 5000ppm | | | | | | | | | | | | | | | | | | | | | | | |
| | 0 to 500ppm 0 to 1000ppm 0 to 2000ppm 0 to 5000ppm | 0 to 1% 0 to 2% 0 to 5% 0 to 10% | | | | | | | | | | | | | | | | | | | | | | | |
| | 0 to 1% 0 to 2% 0 to 2% 0 to 10% 0 to 10% | 0 to 20% 0 to 10% 0 to 50% 0 to 20% 0 to 100% | | | | | | | | | | | | | | | | | | | | | | | |
| | | | | | | | | | | | | | | | | | | | | | | | | | |
| 13 | <Measuring range> 2nd component | note 4 | | | | | | | | | | | | | | | | | | | | | | | |
| 14 | Minimum range Maximum range | | | | | | | | | | | | | | | | | | | | | | | | |
| | None 0 to 50ppm 0 to 100ppm 0 to 200ppm 0 to 200ppm 0 to 200ppm 0 to 200ppm | None 0 to 1000ppm 0 to 2000ppm 0 to 500ppm 0 to 2000ppm 0 to 5000ppm | | | | | | | | | | | | | | | | | | | | | | | |
| | 0 to 500ppm 0 to 1000ppm 0 to 2000ppm 0 to 5000ppm | 0 to 1% 0 to 2% 0 to 5% 0 to 10% | | | | | | | | | | | | | | | | | | | | | | | |
| | 0 to 1% 0 to 2% 0 to 10% 0 to 10% | 0 to 20% 0 to 50% 0 to 20% 0 to 100% | | | | | | | | | | | | | | | | | | | | | | | |
| | | | | | | | | | | | | | | | | | | | | | | | | | |
| 15 | <Measuring range> 3rd component | note 4 | | | | | | | | | | | | | | | | | | | | | | | |
| 16 | Minimum range Maximum range | | | | | | | | | | | | | | | | | | | | | | | | |
| | None 0 to 50ppm 0 to 100ppm 0 to 100ppm 0 to 200ppm 0 to 200ppm 0 to 200ppm | None 0 to 1000ppm 0 to 1000ppm 0 to 2000ppm 0 to 500ppm 0 to 2000ppm 0 to 5000ppm | | | | | | | | | | | | | | | | | | | | | | | |
| | 0 to 500ppm 0 to 1000ppm 0 to 2000ppm 0 to 5000ppm | 0 to 1% 0 to 2% 0 to 5% 0 to 10% | | | | | | | | | | | | | | | | | | | | | | | |
| | 0 to 1% 0 to 2% 0 to 10% 0 to 10% | 0 to 20% 0 to 10% 0 to 20% 0 to 100% | | | | | | | | | | | | | | | | | | | | | | | |
| | | | | | | | | | | | | | | | | | | | | | | | | | |

| Digit | Description | note | 1 | 2 | 3 | 4 | 5 | 6 | 7 | 8 | 9 | 10 | 11 | 12 | 13 | 14 | 15 | 16 | 17 | 18 | 19 | 20 | 21 | 22 | 23 | | | | | | | | | | | | | | | | | | | | | | | | | | | | |
|---------------|---|--|---------------|------|------|------------|--------------|-------------|--------------|-------------|-------------|-------------|--------------|-------------|--------------|-------------|---------|--------------|---------|--------------|----------|---------|----------|---------|----------|----------|----------|----------|-----------|--|--|--|--|--|--|--|--|--|--|--|--|--|--|--|--|--|--|--|--|--|--|--|--|
| 17 | <Measuring range> 4th component | note 4 | Z | K | J | F | | 6 | | | | | | | | | | | | | | | | | | | | | | | | | | | | | | | | | | | | | | | | | | | | | |
| 18 | <table border="1"> <thead> <tr> <th>Minimum range</th> <th>Maximum range</th> </tr> </thead> <tbody> <tr><td>None</td><td>None</td></tr> <tr><td>0 to 50ppm</td><td>0 to 1000ppm</td></tr> <tr><td>0 to 100ppm</td><td>0 to 2000ppm</td></tr> <tr><td>0 to 200ppm</td><td>0 to 500ppm</td></tr> <tr><td>0 to 200ppm</td><td>0 to 2000ppm</td></tr> <tr><td>0 to 200ppm</td><td>0 to 5000ppm</td></tr> <tr><td>0 to 500ppm</td><td>0 to 1%</td></tr> <tr><td>0 to 1000ppm</td><td>0 to 2%</td></tr> <tr><td>0 to 5000ppm</td><td>0 to 10%</td></tr> <tr><td>0 to 1%</td><td>0 to 20%</td></tr> <tr><td>0 to 2%</td><td>0 to 50%</td></tr> <tr><td>0 to 10%</td><td>0 to 20%</td></tr> <tr><td>0 to 10%</td><td>0 to 100%</td></tr> </tbody> </table> | Minimum range | Maximum range | None | None | 0 to 50ppm | 0 to 1000ppm | 0 to 100ppm | 0 to 2000ppm | 0 to 200ppm | 0 to 500ppm | 0 to 200ppm | 0 to 2000ppm | 0 to 200ppm | 0 to 5000ppm | 0 to 500ppm | 0 to 1% | 0 to 1000ppm | 0 to 2% | 0 to 5000ppm | 0 to 10% | 0 to 1% | 0 to 20% | 0 to 2% | 0 to 50% | 0 to 10% | 0 to 20% | 0 to 10% | 0 to 100% | | | | | | | | | | | | | | | | | | | | | | | | |
| Minimum range | Maximum range | | | | | | | | | | | | | | | | | | | | | | | | | | | | | | | | | | | | | | | | | | | | | | | | | | | | |
| None | None | | | | | | | | | | | | | | | | | | | | | | | | | | | | | | | | | | | | | | | | | | | | | | | | | | | | |
| 0 to 50ppm | 0 to 1000ppm | | | | | | | | | | | | | | | | | | | | | | | | | | | | | | | | | | | | | | | | | | | | | | | | | | | | |
| 0 to 100ppm | 0 to 2000ppm | | | | | | | | | | | | | | | | | | | | | | | | | | | | | | | | | | | | | | | | | | | | | | | | | | | | |
| 0 to 200ppm | 0 to 500ppm | | | | | | | | | | | | | | | | | | | | | | | | | | | | | | | | | | | | | | | | | | | | | | | | | | | | |
| 0 to 200ppm | 0 to 2000ppm | | | | | | | | | | | | | | | | | | | | | | | | | | | | | | | | | | | | | | | | | | | | | | | | | | | | |
| 0 to 200ppm | 0 to 5000ppm | | | | | | | | | | | | | | | | | | | | | | | | | | | | | | | | | | | | | | | | | | | | | | | | | | | | |
| 0 to 500ppm | 0 to 1% | | | | | | | | | | | | | | | | | | | | | | | | | | | | | | | | | | | | | | | | | | | | | | | | | | | | |
| 0 to 1000ppm | 0 to 2% | | | | | | | | | | | | | | | | | | | | | | | | | | | | | | | | | | | | | | | | | | | | | | | | | | | | |
| 0 to 5000ppm | 0 to 10% | | | | | | | | | | | | | | | | | | | | | | | | | | | | | | | | | | | | | | | | | | | | | | | | | | | | |
| 0 to 1% | 0 to 20% | | | | | | | | | | | | | | | | | | | | | | | | | | | | | | | | | | | | | | | | | | | | | | | | | | | | |
| 0 to 2% | 0 to 50% | | | | | | | | | | | | | | | | | | | | | | | | | | | | | | | | | | | | | | | | | | | | | | | | | | | | |
| 0 to 10% | 0 to 20% | | | | | | | | | | | | | | | | | | | | | | | | | | | | | | | | | | | | | | | | | | | | | | | | | | | | |
| 0 to 10% | 0 to 100% | | | | | | | | | | | | | | | | | | | | | | | | | | | | | | | | | | | | | | | | | | | | | | | | | | | | |
| 19 | <O ₂ analyzer, 1st range> | note 4 | | | | | | | | | | | | | | | | | | | | | | | | | | | | | | | | | | | | | | | | | | | | | | | | | | | |
| 20 | <table border="1"> <thead> <tr> <th>Minimum range</th> <th>Maximum range</th> </tr> </thead> <tbody> <tr><td>None</td><td>None</td></tr> <tr><td>0 to 5%</td><td>0 to 25%</td></tr> <tr><td>0 to 10%</td><td>0 to 25%</td></tr> <tr><td>Other</td><td></td></tr> </tbody> </table> | Minimum range | Maximum range | None | None | 0 to 5% | 0 to 25% | 0 to 10% | 0 to 25% | Other | | | | | | | | | | | | | | | | | | | | | | | | | | | | | | | | | | | | | | | | | | | |
| Minimum range | Maximum range | | | | | | | | | | | | | | | | | | | | | | | | | | | | | | | | | | | | | | | | | | | | | | | | | | | | |
| None | None | | | | | | | | | | | | | | | | | | | | | | | | | | | | | | | | | | | | | | | | | | | | | | | | | | | | |
| 0 to 5% | 0 to 25% | | | | | | | | | | | | | | | | | | | | | | | | | | | | | | | | | | | | | | | | | | | | | | | | | | | | |
| 0 to 10% | 0 to 25% | | | | | | | | | | | | | | | | | | | | | | | | | | | | | | | | | | | | | | | | | | | | | | | | | | | | |
| Other | | | | | | | | | | | | | | | | | | | | | | | | | | | | | | | | | | | | | | | | | | | | | | | | | | | | | |
| 21 | <Output> 4 to 20mA DC 0 to 1V DC 4 to 20mA DC + Communication function 0 to 1V DC + Communication function | | | | | | | | | | | | | | | | | | | | | | A | | | | | | | | | | | | | | | | | | | | | | | | | | | | | | |
| 22 | <O ₂ conversion and O ₂ average value output> None With O ₂ conversion output With peak alarm With O ₂ conversion output and peak alarm | note 6 note 7 | | | | | | | | | | | | | | | | | | | | | | Y | | | | | | | | | | | | | | | | | | | | | | | | | | | | | |
| 23 | <Adjustment, Range designation> For combustion exhaust gas (specified range) For combustion exhaust gas For combustion exhaust gas (specified range) Unit mg/m ³ For combustion exhaust gas, Unit mg/m ³ Others | note 8a) note 8a)b) note 8b) note 9 | | | | | | | | | | | | | | | | | | | | | | B | | | | | | | | | | | | | | | | | | | | | | | | | | | | | |
| | | | | | | | | | | | | | | | | | | | | | | | | E | | | | | | | | | | | | | | | | | | | | | | | | | | | | | |
| | | | | | | | | | | | | | | | | | | | | | | | | | F | | | | | | | | | | | | | | | | | | | | | | | | | | | | |
| | | | | | | | | | | | | | | | | | | | | | | | | | G | | | | | | | | | | | | | | | | | | | | | | | | | | | | |
| | | | | | | | | | | | | | | | | | | | | | | | | | Z | | | | | | | | | | | | | | | | | | | | | | | | | | | | |

- Note 1** a) When "B" is specified at the 6th digit, O₂ sensor signal has to be set as 0-1V DC linear corresponding to full scale.
b) External Zirconia O₂ sensor and external O₂ analyzer are not included in the scope of supply, and has to be separately ordered.
- Note 2** Resin coupling with purging cannot be manufactured.
- Note 3** Rated voltage, plug type and applicable standard of the attached power cord is different depending on the code "J", "E", "U" and "C" in the 10th digit.
Select appropriate cord according to operating power supply voltage in the final destination.
- Note 4** Measuring range can be selected within either the minimum or maximum range.
(Within min. or max. range, you can change the actual range settings locally.)
Initial setting from Fuji factory is Min. range for the 1st range, and Max. range for the 2nd range.
When range preset at Fuji factory is required, please select "specified range" at 23rd digit and inform Fuji of specified range table.
Refer to Section 9.3 (1) - (8), for possible combination of measuring components and ranges in the data sheet.
- Note 5** "1E" can be specified at 11th & 12th digits, ONLY for CO₂ measurement.
In this case, be sure to select "with purging" at 7th digit.
- Note 6** O₂ conversion is calculated only for NO, SO₂ and CO.
Both average value output after O₂ calculation and O₂ average value output are provided at the same time.
a) Peak count alarm can be added only for CO measurement.
- Note 7** When "Y" is specified at the 6th digit, 22nd digit always has to be specified as "Y".
- Note 8** a) If you would like Fuji to deliver ZKJ analyzer with specific range setting, select "specified range" and separately inform Fuji of the actual range of each component together with your purchase order.
b) In case that the measurement unit is specified as "mg/m³", it is necessary to select "unit : mg/m³" (Code "F" or "G") at the 23rd digit.
Please refer to the table shown below for the corresponding range code based on "mg/m³".

| Range code | In ppm | | Corresponding range in mg/m ³ or g/m ³ | | | | | |
|------------|------------|------------|--|-------------------------|------------------------|-------------------------|------------------------|-------------------------|
| | Min. range | Max. range | NO | | SO ₂ | | CO | |
| AF | 0-50ppm | 0-1000ppm | 0-70mg/m ³ | 0-1300mg/m ³ | 0-150mg/m ³ | 0-2800mg/m ³ | 0-65mg/m ³ | 0-1250mg/m ³ |
| BG | 0-100ppm | 0-2000ppm | 0-140mg/m ³ | 0-2600mg/m ³ | 0-300mg/m ³ | 0-5500mg/m ³ | 0-130mg/m ³ | 0-2500mg/m ³ |
| CH | 0-200ppm | 0-5000ppm | 0-280mg/m ³ | 0-6600mg/m ³ | 0-600mg/m ³ | 0-14g/m ³ | 0-250mg/m ³ | 0-6250mg/m ³ |

- Note 9** When "Z" is specified at the 23rd digit, a gas composition table of actual measured gas has to be sent to Fuji together with your purchase order.
- Note 10** When only N₂O analyzer is used, make sure not to contain any components other than N₂O.
Multicomponent analyzers including N₂O analyzer + CO₂ analyzer are used for sludge incineration.
In this case, the range of N₂O is 0 to 200ppm/500ppm, and the range of CO₂ is 0 to 10%/20%.

9.3 Measurable component and range – availability check table –

(1) Components of single-component analyzer and double-component analyzer (NO/CO), and CO of 3-component analyzer (NO/SO₂/CO)

As shown in the range code, when "P", "A", "D", "B", and "E" are specified at 5th digit, each component is given at 11th and 12th digits.
 When "H" is specified, NO is given at 11th and 12th digits and CO at 13th and 14th digits.
 When "L" is specified, CO is given at 15th and 16th digits.

| Code symbol 5th digit | Range code | 1E | AF | BG | CH | EJ | FK |
|--------------------------|-----------------|---------------------|----------------------|-----------------------|-----------------------|------------------|-------------------|
| | Range | 0-20ppm 0-500ppm | 0-50ppm 0-1000ppm | 0-100ppm 0-2000ppm | 0-200ppm 0-5000ppm | 0-500ppm 0-1% | 0-1000ppm 0-2% |
| Components | | | | | | | |
| P,H | NO | | ○ | ○ | ○ | | |
| A | SO ₂ | | ○ | ○ | ○ | ○ | |
| D | CO ₂ | ○ | ○ | ○ | ○ | ○ | ○ |
| B,H,L | CO | | ○◎ | ○◎ | ○◎ | ○ | ○ |
| E | CH ₄ | | | | ○ | ○ | ○ |

| Code symbol 5th digit | Range code | GL | HM | JN | KM | KP | MR | CG |
|--------------------------|------------------|------------------|--------------------|---------------|---------------|---------------|-----------------|-----------------------|
| | Range | 0-200ppm 0-5% | 0-5000ppm 0-10% | 0-1% 0-20% | 0-2% 0-10% | 0-2% 0-50% | 0-10% 0-100% | 0-200ppm 0-2000ppm |
| Components | | | | | | | | |
| P,H | NO | | | | | | | |
| A | SO ₂ | | | | ○ | | | |
| D | CO ₂ | ○ | ○ | ○ | | ○ | ○ | |
| B,H,L | CO | | ○ | ○ | | ○ | ○ | |
| E | CH ₄ | ○ | ○ | ○ | | ○ | ○ | |
| Q | N ₂ O | | | | | | | ○ |

○ : Single component analyzers (5th code P, A, D, B, E), NO of NO/CO analyzer (5th code H)
 ◎ : CO of NO/CO analyzer (5th code H) , CO of NO/SO₂/CO analyzer (5th code L)

(2) NO/SO₂ of double-component analyzer (NO/SO₂), three-component analyzer (NO/SO₂/CO) and 4-component analyzer (NO/SO₂/CO₂/CO)

Selection of NO/SO₂ when "F", "L", and "M" are specified at 5th digit of the code symbol.

| Measurable components | Code symbol, 11th, and 12th digits. | 2nd | 2nd component SO ₂ | | |
|-----------------------|-------------------------------------|-----------------------|-------------------------------------|----|----|
| | | | Code symbol, 13th, and 14th digits. | AF | BG |
| 1st component, NO | AF | 0-50ppm 0-1000ppm | ○ | ○ | |
| | BG | 0-100ppm 0-2000ppm | ○ | ○ | |
| NO | CH | 0-200ppm 0-5000ppm | | | ○ |

○ : Combination is available.

(3) CO₂/CO of 2-component analyzer (CO₂/CO) and 4-component analyzer (NO/SO₂/CO₂/CO)

When "G" is specified at 5th digit, CO₂ is given at 11th and 12th digits, and CO at 13th and 14th digits.
 When "M" is specified, CO₂ is given at 15th and 16th digits, and CO at 17th and 17th digits.

| Measurable components | Range code | 2nd | 2nd component, CO | | | | | | | | | |
|--------------------------------|------------|-----------------------|-------------------|----|----|----|----|----|----|----|----|---|
| | | | AF | BG | CH | EJ | FK | HM | JN | KP | MR | |
| 1st component, CO ₂ | AF | 0-50ppm 0-1000ppm | ○◎ | ○◎ | ○◎ | | | | | | | |
| | BG | 0-100ppm 0-2000ppm | ○◎ | ○◎ | ○◎ | ○ | | | | | | |
| CO ₂ | CH | 0-200ppm 0-5000ppm | ○◎ | ○◎ | ○◎ | ○ | | | | | | |
| | EJ | 0-500ppm 0-1% | | | | ○ | ○ | | | | | |
| | FK | 0-1000ppm 0-2% | | | | | ○ | | | | | |
| | GL | 0-2000ppm 0-5% | | | | | | ○ | | | | |
| | HM | 0-5000ppm 0-10% | | | | | | ○ | ○ | | | |
| | JN | 0-1% 0-20% | | | | | | | ○ | ○ | | |
| | KP | 0-2% 0-50% | | | | | | | | ○ | | |
| | MR | 0-10% 0-100% | | | | | | | | | | ○ |
| | MN | 0-10% 0-20% | ○◎ | ○◎ | ○◎ | ○ | | | | | | |

○ : CO₂/CO analyzer (5th code G)
 ◎ : NO/SO₂/CO₂/CO analyzer (5th code M)

(4) N₂O/CO₂ of 2-component analyzer N₂O/CO₂, 3-component analyzer NO/N₂O/CO₂, SO₂/N₂O/CO₂, N₂O/CO₂/CO, CH₄/N₂O/CO₂ and 4-component analyzer (NO/SO₂/N₂O/CO₂)

Range code: When code symbol is "R" or "U", N₂O is 11th and 12th digit, CO₂ is 13th and 14th digit.
 When code symbol is "S", "T" or "V", N₂O is 13th and 14th digit, CO₂ is 15th and 16th digit
 When code symbol is "W", N₂O is 15th and 16th digit, CO₂ is 17th and 18th digit

| | | Measurable components | 2nd component, CO ₂ |
|---------------------------------|------------|-----------------------|--------------------------------|
| | | Range code | MN |
| Measurable components | Range code | / | 0-10% 0-20% |
| 1st component, N ₂ O | CE | 0-200ppm 0-500ppm | ○ |

○ : Combination is available.

(5) CO₂ range selection of 3-component analyzer (N₂O/CO₂/CO)

Range code: N₂O is 11th and 12th digit, CO₂ is 13th and 14th, CO is 15th and 16th digit.
 The range code of CO₂ is "MN".

| | | Measurable components | 2nd component, CO |
|---------------------------------|------------|-----------------------|-----------------------|
| | | Range code | BF |
| Measurable components | Range code | / | 0-100ppm 0-1000ppm |
| 1st component, N ₂ O | CE | 0-200ppm 0-500ppm | ○ |

○ : Combination is available.

(6) SO₂ range selection of 3-component analyzer (SO₂/N₂O/CO₂)

Range code: SO₂ is 11th and 12th digit, N₂O is 13th and 14th, CO₂ is 15th and 16th digit.
 The range code of CO₂ is "MN".

| | | Measurable components | 2nd component, N ₂ O |
|--------------------------------|------------|-----------------------|---------------------------------|
| | | Range code | CE |
| Measurable components | Range code | / | 0-200ppm 0-500ppm |
| 1st component, SO ₂ | AF | 0-50ppm 0-1000ppm | ○ |

○ : Combination is available.

(7) CH₄ range selection of 3-component analyzer (CH₄/N₂O/CO₂)

Range code: CH₄ is 11th and 12th digit, N₂O is 13th and 14th, CO₂ is 15th and 16th digit.
 The range code of CO₂ is "MN".

| | | Measurable components | 2nd component, N ₂ O |
|--------------------------------|------------|-----------------------|---------------------------------|
| | | Range code | CE |
| Measurable components | Range code | / | 0-200ppm 0-500ppm |
| 1st component, CH ₄ | CH | 0-200ppm 0-5000ppm | ○ |

○ : Combination is available.

(8) NO/SO₂/N₂O range selection of 4-component analyzer (NO/SO₂/N₂O/CO₂)

Range code: NO is 11th and 12th digit, SO₂ is 13th and 14th, N₂O is 15th and 16th, CO₂ is 17th and 18th digit.
 The range code of CO₂ is "MN".

| | | Measurable components | 2nd component, SO ₂ | 3rd component, N ₂ O |
|-----------------------|------------|-----------------------|--------------------------------|---------------------------------|
| | | Range code | AF | CE |
| Measurable components | Range code | / | 0-50ppm 0-1000ppm | 0-200ppm 0-500ppm |
| 1st component, NO | AF | 0-50ppm 0-1000ppm | ○ | ○ |
| | BG | 0-100ppm 0-2000ppm | ○ | ○ |

○ : Combination is available.

9.4 Outline diagram <Analyzer main unit>

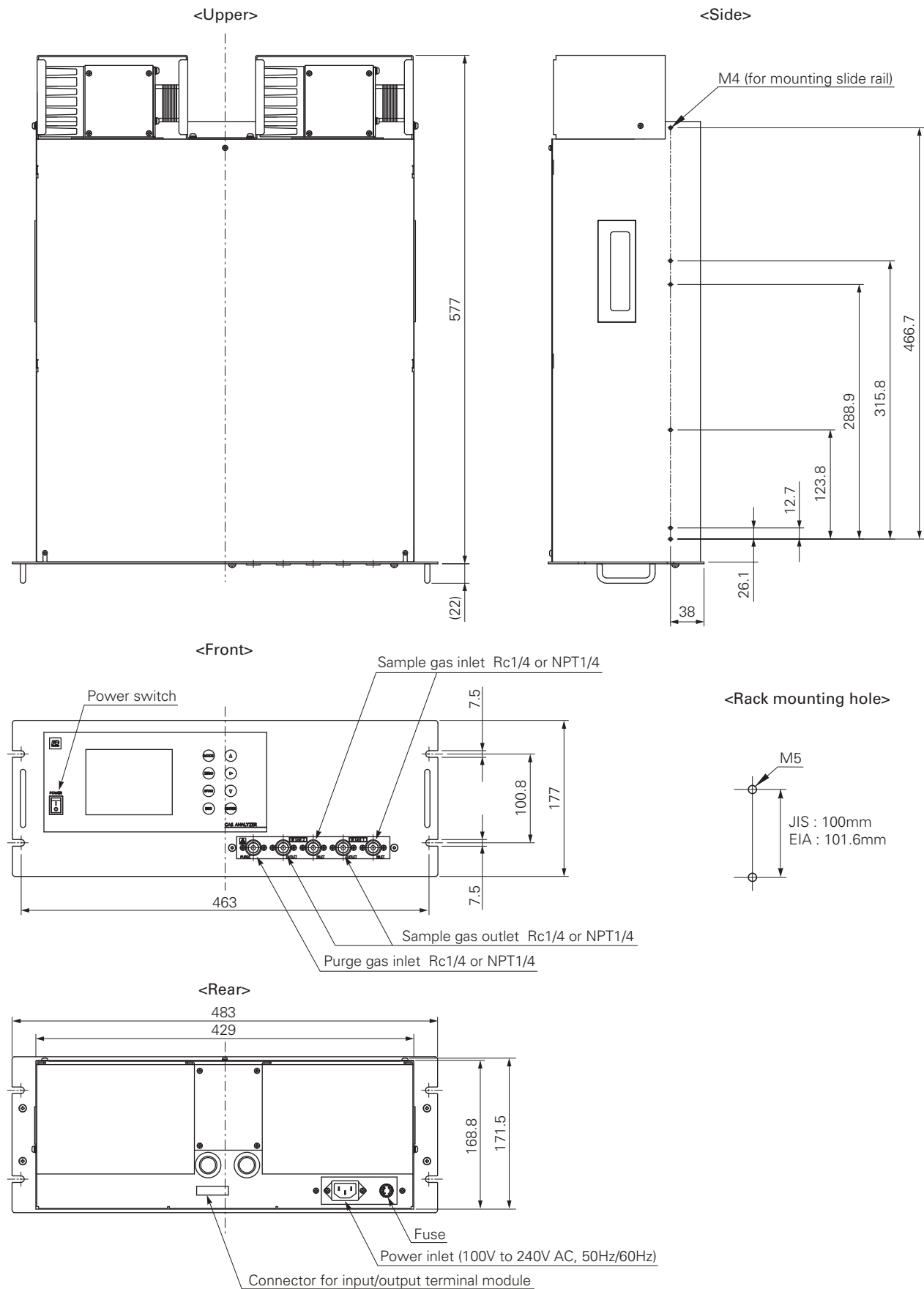

<Input / output terminal module>

(Accessory)

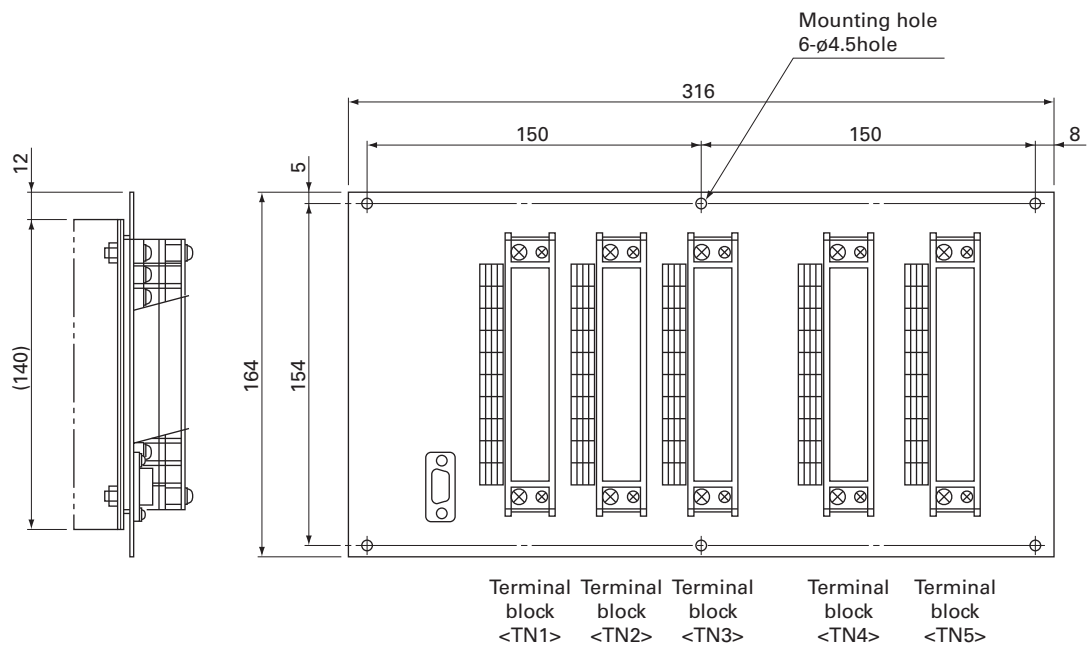

Screw terminals M3.5

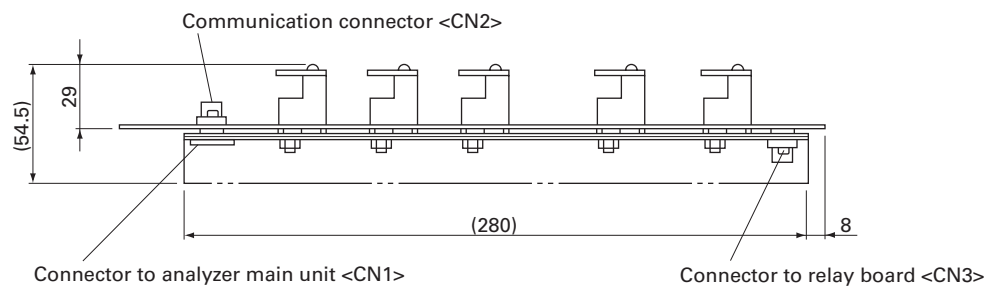

<Cable for connecting input / output terminal>

(Accessory)

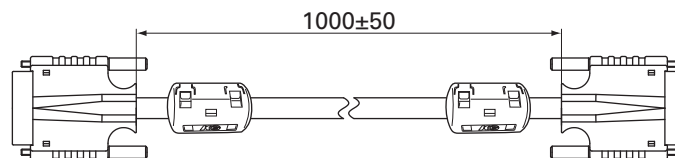

<Dimensions for mounting input / output terminal module>

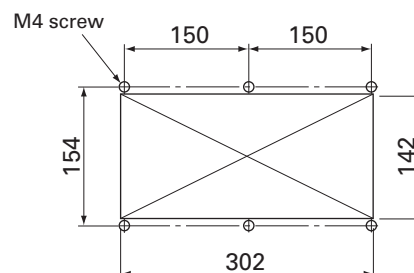

Cut M4 screw holes at 6 positions.
Drill a rectangular hole of 302 x 142mm or more in the center.

Outline diagram of accessory slide rail (unit: mm)

* The slide rails are attached to this equipment when designated.

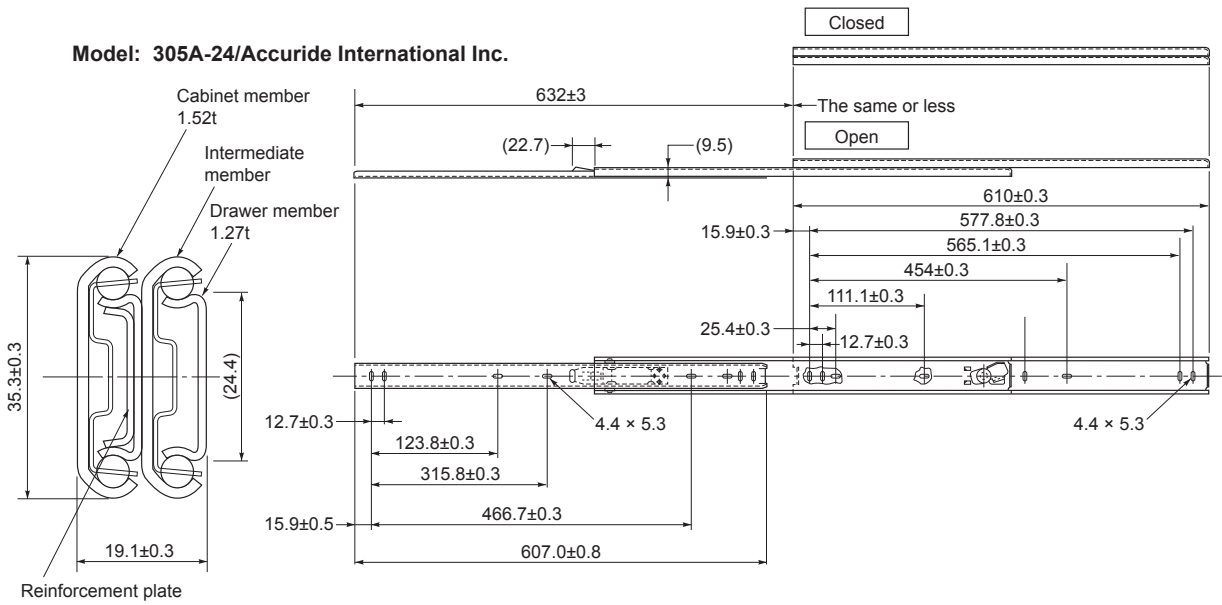

19 inch rack mounting method:

The instrument weight should be supported at the base (at the sides in case of slide rail method). For easy maintenance, it is recommended to select the method to allow withdrawing along the slide rail.

Slide rail mounted type

Guide rail mounted type

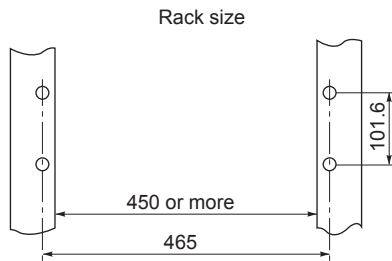
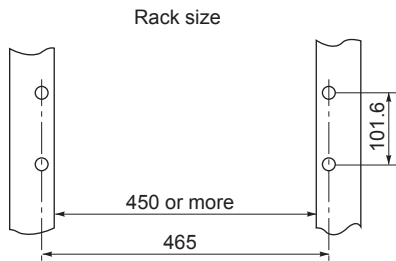

Mounting diagram

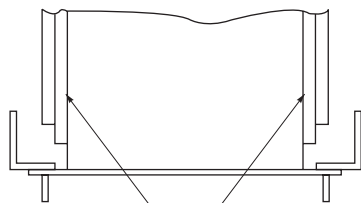

Mounting diagram

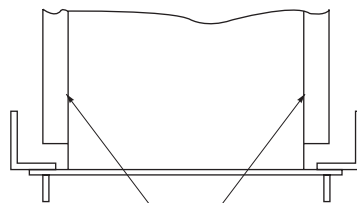

Slide rails

Guide rails

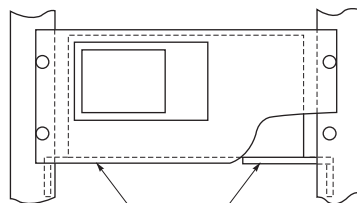
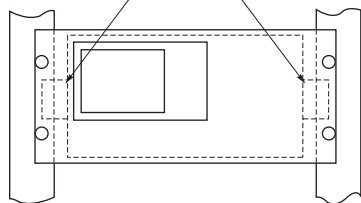

Guide rails

For the guide rail mounted type, a maintenance space (200mm or more) should be provided upper the main unit.

<Exclusive relay board>

The relay board is used for receiving signals from connector CN3 of the ZKJ input/output terminal module and directly driving the solenoid valve for calibration.

- Relay contact : 1a contact
Contact capacity: 250V/2A AC (Resistance load)

OUTLINE DIAGRAM (Unit: mm)

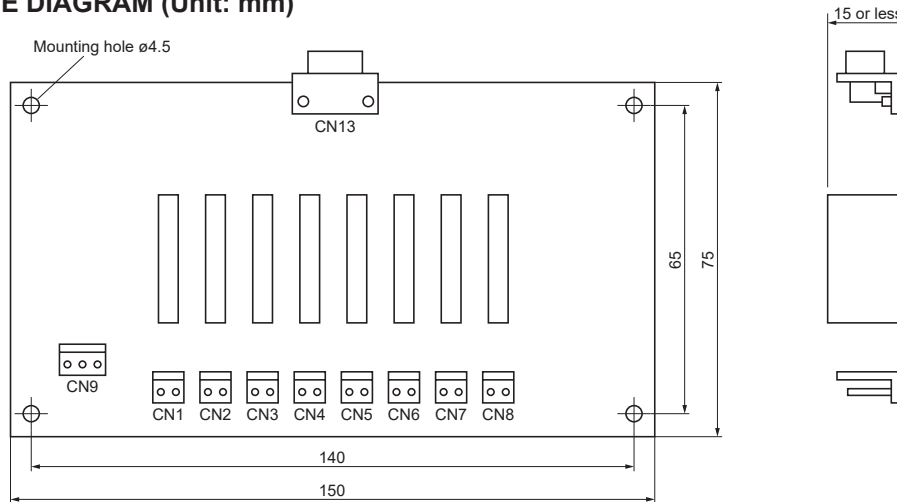

CONNECTIONS

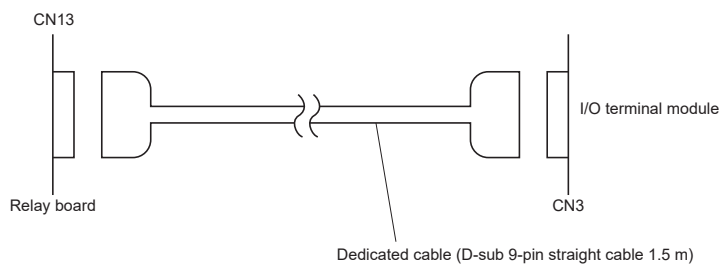
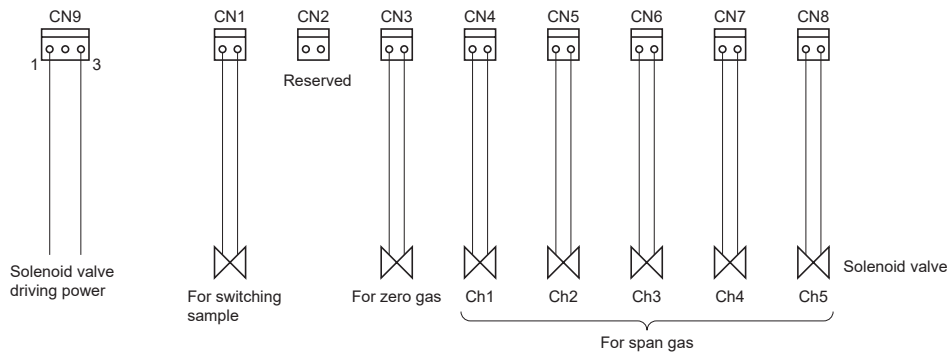

Contact operation

- At the time of measurement:
 - CN1 ON
 - Other OFF
- At the time of calibration:
 - CN1 OFF
 - Other Contacts corresponding to the timing of each calibration are ON.

Recommended connector

- CN1 to CN8:
 - Housing; VHR-2N (J.S.T. Mfg. Co., Ltd.)
- CN9:
 - Housing; VHR-3N (J.S.T. Mfg. Co., Ltd.)
 - Contact; SVH-21T-1.1 (J.S.T. Mfg. Co., Ltd.)
- Allowable:
 - Size; AWG22 to AWG18
 - Covered wire; 1.7mm to 3.0mm

Fuji Electric Co., Ltd.

Instrumentation & Sensors Planning Dept.

1, Fuji-machi, Hino-city, Tokyo 191-8502, Japan

www.fujielectric.com

Phone: +81-42-514-8930 Fax: +81-42-583-8275

www.fujielectric.com/products/instruments/
