



Instruction Manual

**INFRARED GAS
ANALYZER
COMMUNICATION
FUNCTIONS (MODBUS)**

TYPE: ZRJ / ZKJ

CONTENTS

1.	COMMUNICATION FUNCTIONS	1
1.1	General.....	1
2.	SPECIFICAIONS	2
2.1	Communication specifications.....	2
3.	CONNECTION.....	3
3.1	Terminal allocation (Input/output terminal CN2)	3
3.2	Connection	3
4.	SETTING OF COMMUNICATION CONDITION.....	4
4.1	Set items.....	4
4.2	Setting operation	4
5.	MODBUS COMMUNICATION PROTOCOL.....	5
5.1	General.....	5
5.2	Composition of message	6
5.3	Response of slave station	8
5.4	Function code.....	9
5.5	Calculation of error check code (CRC-16)	10
5.6	Transmission control procedure.....	12
6.	DETAILS OF MESSAGE	14
6.1	Read-out of word data [Function code:03 _H]	14
6.2	Read-out of read only word data [Function code:04 _H]	16
6.3	Write-in of word data (1 word) [Function code:06 _H].....	18
6.4	Write-in of continuous word data [Function code:10 _H]	19
7.	ADDRESS MAP AND DATA FORMAT	21
7.1	Data format	21
7.2	Address map	23
7.3	Supplement to address map	35
8.	TROUBLESHOOTING	37

1.1 General

- This instrument provides a communication function through RS-232 interface, which allows data transmit to or receive from the host computer and other devices.
- The communication system is comprised of a master station and slave stations. One slave station (this instrument) can be connected to one master station.
It is also possible to adapt the instrument to the environment of RS-485 interface using RS-232 ↔ RS-485 converter. In this case, up to 31 of slave station (present instrument) can be connected per master station.
- Because the master station can communicate with only one slave station at a time, the destination can be identified by the "Station No" set for each slave station.
- In order that the master station and the slave station can communicate, the format of the transmit/receive data must coincide. In this instrument, the format of the communication data is determined by the MODBUS protocol.

[RS-232 ↔ RS-485 converter] (recommended article)

Type: KS-485 (non-isolated type)/SYSTEM SACOM Corp.

Type: SI-30A (isolated type)/SEKISUI ELECTRONICS Co., Ltd.

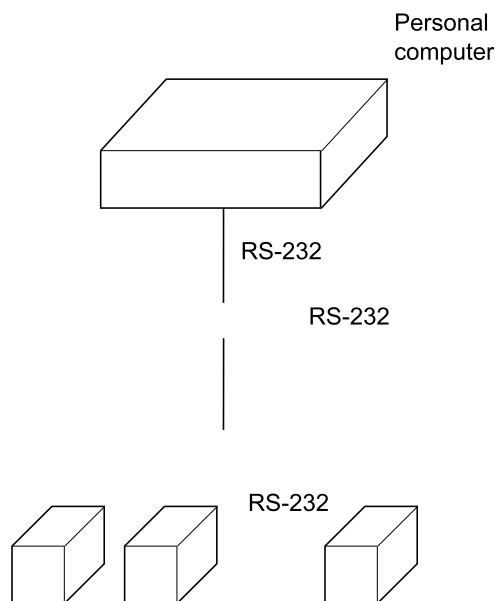

2. SPECIFICATIONS

2.1 Communication specifications

Item	Specification	
Electrical specification	Based on EIA RS-232-C	
Transmission system	2-wire, semi-duplicate	
Synchronizing system	Start-stop synchronous system	
Connection format	1 : 1	
Number connectable units	1 unit (or 31 if RS-485 interface is used)	
Transmission speed	9600bps	
Data format	Data length	8 bits
	Stop bit	1 bit
	Parity	None
	X flow control	None
Transmission code	HEX value (MODBUS RTU mode)	
Error detection	CRC-16	
Isolation	No isolation between transmission circuit and others	

3. CONNECTION

⚠ WARNING

For avoiding electric shock and malfunctions, do not turn on the power supply until all wiring have been completed.

3.1 Terminal allocation (Input/output terminal CN2)

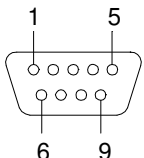
Terminal number	Signal name	Pin connection
2	Recive Data	 9-pin D-Sub (male)
3	Transmit Data	
5	Signal GND	
Others	NC	

3.2 Connection

As connecting cable, use a commercially available RS-232 reverse cable.

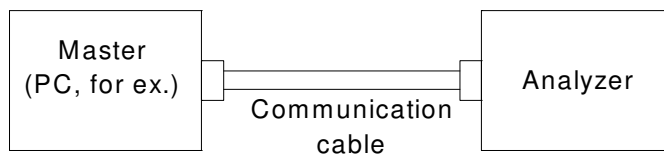

Connect the cable to CN2 on the input/output terminal block (on rear for ZRJ, separate for ZKJ).

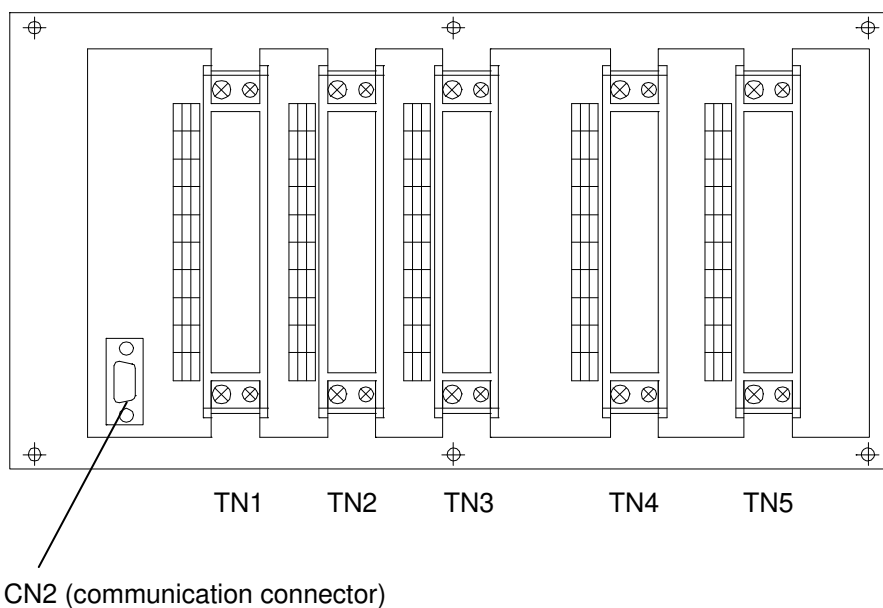

4. SETTING OF COMMUNICATION CONDITION

In order that the master station and instrument can correctly communicate, following settings are required.

- All communication condition settings of the master station are the same as those of instruments.
- All instruments connected on a line are set to "Station Nos. (STno)" which are different from each other. (Any "Station No." is not shared by more than one instrument.)

4.1 Set items

The parameters to be set are shown in the following table. Set them by operating the front panel keys.

Item	Value at delivery	Setting range	Remarks
Transmission speed	9600bps	Fixed (can not be changed)	Set the same communication condition to the master station and all slave stations.
Data length	8 bits	Fixed (can not be changed)	
Stop bit	1 bit	Fixed (can not be changed)	
Parity setting	None	Fixed (can not be changed)	
Station No.	1	0 to 31 (0:communication function stop)	Set a different value to each station.

4.2 Setting operation

Set the station No. on the analyzer maintenance mode display (see the instruction manual).

5. MODBUS COMMUNICATION PROTOCOL

5.1 General

The communication system by the MODBUS protocol is that the communication is always started from the master station and a slave station responds to the received message.

Transmission procedures is as shown below.

- 1) The master station sends a command message to a slave station.
- 2) The slave station checks that the station No. in the received message matches with the own station No. or not.
- 3) If matched, the slave station executes the command and sends back the response message.
- 4) If mismatched, the slave station leaves the command message and wait for the next command message.

- a) In case when the station No. in the received command message matches with the own slave station No.

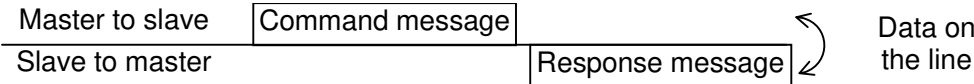

- b) In case when the station No. in the received command message mismatches with the own slave station No.

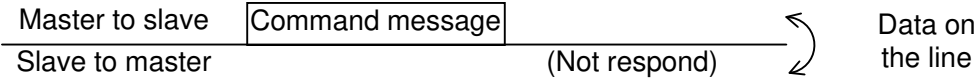

The master station can individually communicate with any one of slave stations connected on the same line upon setting the station No. in the command message.

5.2 Composition of message

Command message and response message consist of 4 fields ; Station No., Function code, Data and Error check code. And these are send in this order.

Station No. (1 byte)
Function code (1 byte)
Data (2 to 133 bytes)
Error check code (CRC-16) (2 bytes)

Fig. 5-1 Composition of message

In the following, each field is explained.

(1) Station No.

Station No. is the number specifying a slave station. Only a slave station that corresponds to a value to which "Station No." is set on the analyzer maintenance mode display executes a command.

(2) Function code

This is a code to designate the function executed at a slave station.
For details, refer to section 5.4.

(3) Data

Data are the data required for executing function codes. The composition of data varies with function codes. For details, refer to chapter 6.

A register number is assigned to each data in the analyzer. For reading/writing the data by communication, designate the register number.

Note that the register number transmitted on message is expressed as its relative address.
The relative address is calculated by the following expression.

$$\boxed{\text{Relative address}} = \left(\text{The lower 4 digits of the } \boxed{\text{Register number}} \right) - 1$$

For example, when the register number designated by a function code is 40003,

$$\begin{aligned} \text{Relative address} &= (\text{lower 4 digits of } 40003) - 1 \\ &= 0002 \end{aligned}$$

is used on the message.

(4) Error check code

This is the code to detect message errors (change in bit) in the signal transmission.

On the MODBUS protocol (RTU mode), CRC-16 (Cyclic Redundancy Check) is applied.

For CRC calculation method, refer to section 5.5.

5.3 Response of slave station

(1) Response for normal command

To a relevant message, the slave station creates and sends back a response message which corresponds to the command message. The composition of message in this case is the same as in section 5.2.

Contents of the data field depend on the function code. For details, refer to Chapter 6.

(2) Response for abnormal command

If contents of a command message have an abnormality (for example, non-actual function code is designated) other than transmission error, the slave station does not execute that command but creates and sends back a response message at error detection.

The composition of response message at error detection is as shown in Fig. 5-2. The value used for function code field is function code of command message plus 80_H.

Table 5-1 gives error codes.

Station No.
Function code + 80 _H
Error code
Error check (CRC-16)

Fig. 5-2 Response message at error detection

Table 5-1 Error code

Error code	Contents	Description
01H	Illegal function	Non-actual function code is designated. Check for the function code.
02H	Illegal data address	A relative address of a register number to which the designated function code can not be used.
03H	Illegal data value	Because the designation of number is too much, the area where register numbers do not exist is designated.

(3) No response

Under any of the following items, the slave station takes no action of the command message and sends back no response.

- A station number transmitted in the command message differs from the station number specified to the slave station.
- A error check code is not matched, or a transmission error (parity error, etc.) is detected.
- The time interval between the composition data of the message becomes longer than the time corresponding to 24 bits. (Refer to section 5.6 Transmission control procedure)

5.4 Function code

According to MODBUS protocol, register numbers are assigned by function codes.
Each function code acts on specific register number.

This correspondence is shown in Table 5-2, and the message length by function is shown in Table 5-3.

Table 5-2 Correspondence between function codes and objective address

Function code			Resister No.	
No.	Function	Object	No.	Contents
03 _H	Read-out (continuously)	Holding register	4xxxx	Read-out/write-in word data
04 _H	Read-out (continuously)	Input register	3xxxx	Read-out word data
06 _H	Write-in	Holding register	4xxxx	Read-out/write-in word data
10 _H	Write-in (continuously)	Holding register	4xxxx	Read-out/write-in word data

Table 5-3 Function code and message length

[Unit : byte]

Function code	Contents	Number of designatable data	Command message		Response message	
			Minimum	Maximum	Minimum	Maximum
03 _H	Read-out of word data	64 words	8	8	7	133
04 _H	Read-out of word data (read-out only)	64 words	8	8	7	133
06 _H	Write-in of word data	1 word	8	8	8	8
10 _H	Write-in of continuous word data	64 words	11	137	8	8

5.5 Calculation of error check code (CRC-16)

CRC-16 is the 2-byte (16-bits) error check code. From the top of the message (station No.) to the end of the data field are calculated.

The slave station calculates the CRC of the received message, and does not respond if the calculated CRC is different from the contents of the received CRC code.

The following shows the calculation procedure for CRC-16.

- (a) Store FFFF_H into 16 bit register (CRC register).
- (b) Subject the 1st byte (8 bits) of transmit message and CRC register contents to an exclusive logical summation (XOR), and store the result into the CRC register.
- (c) Shift the CRC register contents 1 bit to the right. Store 0 at MSB.
- (d) If LSB before shifting is 0, do nothing.
If LSB before shifting is 1, subject it and A001_H to XOR, and store the result into the CRC register.
- (e) Repeat the steps (c) and (d) 8 times (shift by 8 bits).
- (f) Execute steps (b) to (e) for the next byte of the transmit message.
Likewise, successively repeat the steps to each byte of the transmit message.
- (g) The CRC code that is retained is the value of CRC register that stands when the processing has ended for latest byte (latest data except error code) of the transmit message.
- (h) As error check code of the transmit message, store this CRC value in the order of lower 8 bits and upper 8 bits.

Transmit message (ex.)

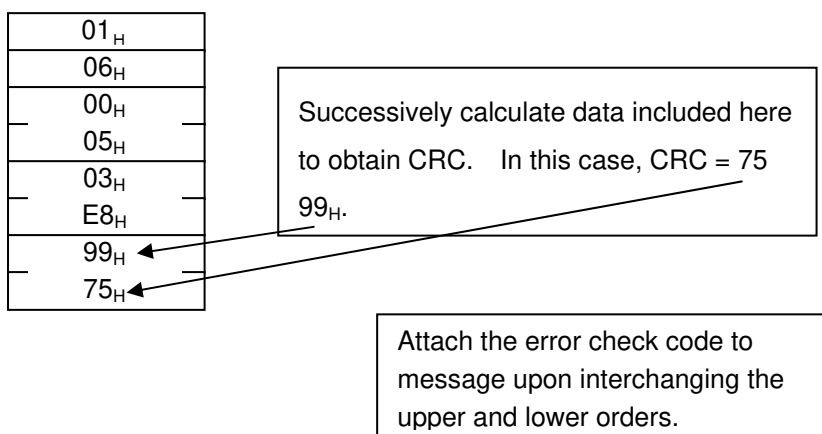

Fig. 5-3 shows the flow of the CRC-16 calculation system.

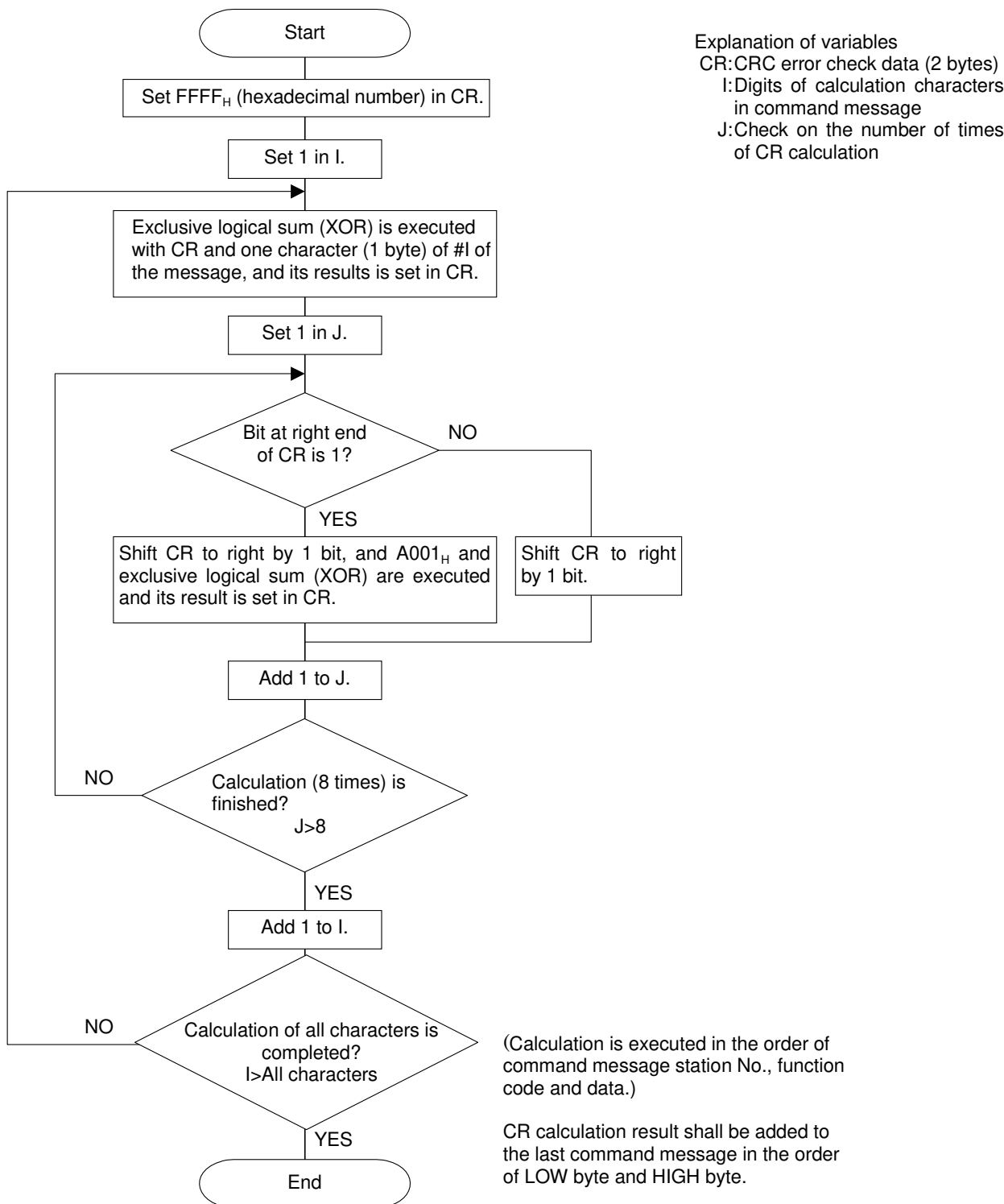

Fig. 5-3 Flow of CRC-16 calculation

5.6 Transmission control procedure

(1) Transmission procedure of master station

The master station must proceed to a communication upon conforming to the following items.

- (1-1) Before sending a command message, provide 48 bits time or more vacant status.
- (1-2) For sending, the interval between bytes of a command message is below 24 bits time.
- (1-3) Within 24 bits time after sending a command message, the receiving status is posted.
- (1-4) Provide 48 bits time or more vacant status between the end of response message reception and beginning of next command message sending [same as in (1-1)].
- (1-5) For ensuring the safety, make a confirmation of the response message and make an arrangement so as to provide 3 times or more retries in case of no response, error occurrence, etc.

Note) The above definition is for most unfavorable value. For ensuring the safety, it's recommended the program of the master to work with safety factors of 2 to 3. Concretely, it is advised to arrange the program for 9600 bps with 10 ms or more for vacant status (1-1), and within 1 ms for byte interval (1-2) and changeover from sending to receiving (1-3).

(2) Description

1) Detection of the message frame

The status on the line of the communication system is one of the 2 below.

- (a) Vacant status (no data on line)
- (b) Communication status (data is existing)

Instruments connected on the line are initially at a receiving status and monitoring the line. When 24 bits time or more vacant status has appeared on the line, the end of preceding frame is assumed and, within following 24 bits time, a receiving status is posted. When data appears on the line, instruments receive it while 24 bits time or more vacant status is detected again, and the end of that frame is assumed. I.e., data which appeared on the line from the first 24 bits time or more vacant status to the next 24 bits time or more vacant status is fetched as one frame.

Therefore, one frame (command message) must be sent upon confirming the following.

- (1-1) 48 bits time or more vacant status precedes before the command message sending.
- (1-2) Interval between bytes of 1 command message is smaller than 24 bits time.

2) Response of this instrument

After a frame detection (24 bits time or more vacant status), this instrument carries out processing with that frame as a command message. If the command message is destined to the own station, a response message is returned. Its processing time is 1 to 30 ms (depends on contents of command message). After sending a command message, therefore, the master station must observe the following.

- (1-3) Receiving status is posted within 24 bits time after sending a command message.

Space time of longer than 5ms is needed
(longer than 10ms is recommended)

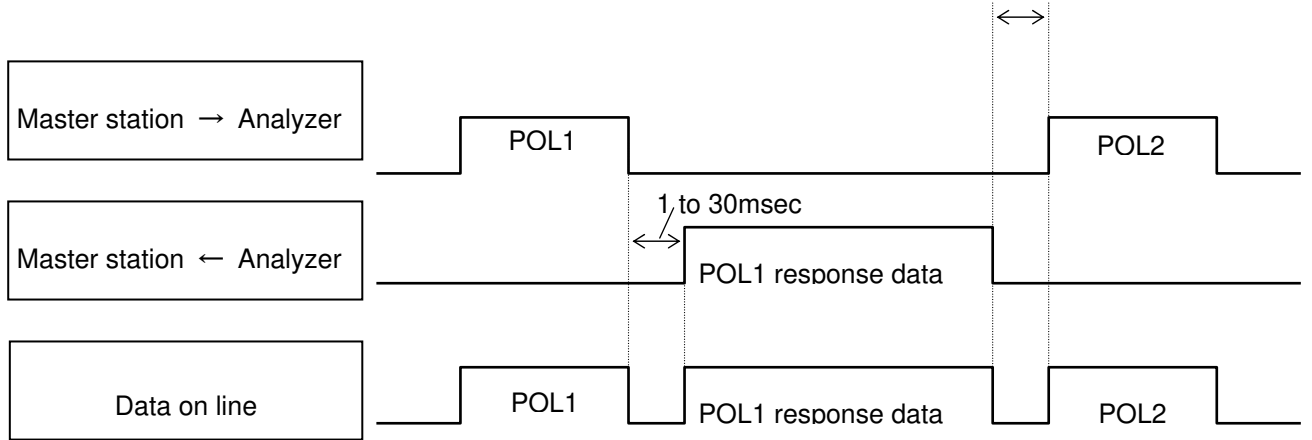

6. DETAILS OF MESSAGE

6.1 Read-out of word data [Function code:03_H]

Function code	Max. word number read-out in one message	Relative data address	Register No.	Contents
03 _H	64 words	0000 _H —006D _H	40001—40110	User setting

(1) Message composition

Command message composition (byte)

Station No.	
Function code	
Read-out start No. (relative address)	Upper
	Lower
Read-out word number	Upper
	Lower
CRC data	Lower
	Upper

} 1 to 64

Response message composition (byte)

Station No.	
Function code	
Read-out byte number	
Contents of the first word data	Upper
	Lower
Contents of the next word data	Upper
	Lower
Contents of the last word data	Upper
	Lower
CRC data	Lower
	Upper

Read-out word number × 2

* Arrangement of read-out word data

MSB	LSB
Upper byte of contents of the first word data	
Lower byte of contents of the first word data	
Upper byte of contents of the next word data	
Lower byte of contents of the next word data	
Upper byte of contents of the last word data	
Lower byte of contents of the last word data	

(2) Function explanations

Word data of continuous word numbers from the read-out start No. can be read. Read-out word data are transmitted from the slave station in the order of upper and lower bytes.

(3) Message transmission (example)

The following shows an example of reading out from No. 1 station the setting CH2 (2nd component) range-1 zero and span calibration concentration.

Relative address of CH2 range-1 zero calibration concentration setting: 0004_H Data number: 02_H

Command message composition (byte)

Station No.	01 _H	
Function code	03 _H	
Read-out start No. (relative address)	Upper	00 _H
	Lower	04 _H
Read-out word number	Upper	00 _H
	Lower	02 _H
CRC data	Lower	85 _H
	Upper	CA _H

Response message composition (byte)

Station No.	01 _H	
Function code	03 _H	
Read-out byte number	04 _H	
Contents of the first word data	Upper	00 _H
	Lower	00 _H
Contents of the next word data	Upper	03 _H
	Lower	E8 _H
CRC data	Lower	FA _H
	Upper	8D _H

* Meaning of read-out data

CH2 range-1 zero calibration concentration setting 00 00_H = 0
(contents of first word data)

CH2 range-1 span calibration concentration setting 03 E8_H = 1000
(contents of next word data)

Provided decimal point position = 1, measurement unit = 1,

CH2 range-1 zero calibration concentration = 0.0 ppm

CH2 range-1 span calibration concentration = 100.0 ppm



For handling of decimal point and unit, refer to Section 7.1.

6.2 Read-out of read only word data [Function code:04_H]

Function code	Max. word number read-out in one message	Relative data address	Resister No.	Contents
04 _H	64 words	0000 _H —00BD _H	30001—30190	Measurement value and status
		0425 _H —0447 _H	31062—31096	Fixed setting

(1) Message composition

Command message composition (byte)

Station No.	
Function code	
Read-out start No. (relative address)	Upper
	Lower
Read-out word number	Upper
	Lower
CRC data	Lower
	Upper

Response message composition (byte)

Station No.		Read-out word number × 2
Function code		
Read-out byte number		
Contents of the first word data	Upper	
	Lower	
Contents of the next word data	Upper	
	Lower	
—		
Contents of the last word data	Upper	
	Lower	
CRC data	Lower	
	Upper	

* Arrangement of read-out word data

MSB	LSB
Upper byte of contents of the first word data	
Lower byte of contents of the first word data	
Upper byte of contents of the next word data	
Lower byte of contents of the next word data	
—	
Upper byte of contents of the last word data	
Lower byte of contents of the last word data	

(2) Function explanations

Word data of continuous word numbers from the read-out start No. can be read. Read-out word data are transmitted from the slave station in the order of upper and lower bytes.

(3) Message transmission (example)

The following shows an example of reading out from No. 1 station the CH5 measurement concentration, decimal point position and measurement unit.

Relative address of CH5 measurement concentration: 000C_H Data number: 03_H

Command message composition (byte)

Station No.		01 _H
Function code		04 _H
Read-out start No. (relative address)	Upper	00 _H
	Lower	0C _H
Read-out word number	Upper	00 _H
	Lower	03 _H
CRC data	Lower	70 _H
	Upper	08 _H

Response message composition (byte)

Station No.		01 _H
Function code		04 _H
Read-out byte number		06 _H
Contents of the first word data	Upper	04 _H
	Lower	B0 _H
Next word data contents	Upper	00 _H
	Lower	02 _H
Latest word data contents	Upper	00 _H
	Lower	00 _H
CRC data	Lower	81 _H
	Upper	0D _H

* Meaning of read-out data

First word data contents 04 B0_H = 1200
 Next word data contents 00 02_H = 2 (decimal point position)
 Latest word data contents 00 00_H = 0 (vol %)

In the above case, measurement concentration = 12.00 vol%

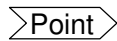

For handling of decimal point and unit, refer to Section 7.1.

6.3 Write-in of word data (1 word) [Function code:06_H]

Function code	Max. word number write-in in one message	Relative data address	Resister No.	Contents
06 _H	1 word	0000 _H –006D _H	40001–40110	User setting
		07D0 _H –07D1 _H	42001–42002	Operation command

(1) Message composition

Command message composition (byte)

Station No.	
Function code	
Write-in designate No. (relative address)	Upper
	Lower
Write-in word data	Upper
	Lower
CRC data	Lower
	Upper

Response message composition (byte)

Station No.	
Function code	
Write-in designate No. (relative address)	Upper
	Lower
Write-in word data	Upper
	Lower
CRC data	Lower
	Upper

(2) Function explanation

Designated word data is written in write-in designate No. Write-in data are transmitted from master station in the order of upper and lower bytes.

(3) Message transmission (example)

The following shows an example of transmitting the "ZERO" key command to No. 1 station.
Key operation command Relative address: 07D0_H

Command message composition (byte)

Station No.		01 _H
Function code		06 _H
Write-in designate No. (relative address)	Upper	07 _H
	Lower	D0 _H
Write-in word data	Upper	00 _H
	Lower	40 _H
CRC data	Lower	88 _H
	Upper	B7 _H

} ZERO key command

Response message composition (byte)

Station No.		01 _H
Function code		06 _H
Write-in designate No. (relative address)	Upper	07 _H
	Lower	D0 _H
Write-in word data	Upper	00 _H
	Lower	40 _H
CRC data	Lower	88 _H
	Upper	B7 _H

6.4 Write-in of continuous word data [Function code:10_H]

Function code	Max. word number write-in in one message	Relative data address	Resister No.	Kind of data
10 _H	64 words	0000 _H —006D _H	40001—40110	User setting

(1) Message composition

Command message composition (byte)

Station No.	
Function code	
Write-in start No. (relative address)	Upper
	Lower
Write-in word number	Upper
	Lower
Write-in byte number	
First write-in word data	Upper
	Lower
Next write-in word data	Upper
	Lower
Last write-in word data	Upper
	Lower
CRC data	Lower
	Upper

} 1 to 64

} Write-in word number × 2

Response message composition (byte)

Station No.	
Function code	
Write-in start No. (relative address)	Upper
	Lower
Write-in word number	Upper
	Lower
CRC data	Lower
	Upper

* Arrangement of write-in word data

MSB	LSB
Upper byte of contents of the first word data	
Lower byte of contents of the first word data	
Upper byte of contents of the next word data	
Lower byte of contents of the next word data	
Upper byte of contents of the last word data	
Lower byte of contents of the last word data	

(2) Function explanation

Word data of continuous word number is written from write-in start address. Write-in word data are transmitted from master station in the order of upper and lower bytes.

7. ADDRESS MAP AND DATA FORMAT

7.1 Data format

7.1.1 Transmission data format

The MODBUS protocol used in this instrument is RTU (Remote Terminal Unit) mode. Transmitted data is "numeric value" and not ASCII code".

7.1.2 Handling of decimal point position and measurement unit

When transmitted, the calibration concentration setting, alarm's high and low limits and measurement concentration data have no decimal point nor measurement unit.

Calculate exact values of data upon point positioning as shown below.

- (a) Calibration concentration setting (register No. 40001 to 40020)
Alarm setting (register No. 40036 to 40055)

You can know the point position for each CH (channel) and each range, and unit upon reading in the decimal point position data (register No. 31087 to 31096), and the unit data (register No. 31067 to 31076).

The decimal point position data has a value of 0, 1, 2 or 3. You can obtain an exact value by the following calculation.

- Case 0: Calibration concentration setting data /1
- Case 1: Calibration concentration setting data /10
- Case 2: Calibration concentration setting data /100
- Case 3: Calibration concentration setting data /1000

The unit data has a value of 0, 1, 2 or 3, that corresponds as follows.

- Case 0: vol%
- Case 1: ppm
- Case 2: mg/m³
- Case 3: g/m³

For example, if:

- CH1 range-1 span calibration concentration setting (register No. 40002) = 2000,
- CH1 range-1 decimal point position (register No. 31087) = 1, and
- CH1 range-1 unit (register No. 31067) = 1,

the value is 200.0 ppm.

For writing-in, proceed in the reverse. To obtain 200.0 ppm, write 2000 as calibration concentration setting.

The decimal point position and unit are unchangeable because fixed to each CH and each range.

(b) Measurement concentration (register No. 30001 to 30036)

The decimal point position and measurement unit for each concentration are stored in registers following that of concentration, and can be known by reading them in.

The meaning of decimal point position data and measurement unit data values are the same as in (a) above.

For example, if:

CH3 measurement concentration (register No. 30007) = 1270,

CH3 decimal point position (register No. 30008) = 2,

CH3 measurement unit (register No. 30009) = 0,

the value is 12.70 vol%

7.1.3 Handling at measurement data over-range

Even if the measurement data is at over-range, with "— — — —" displayed on the screen, the concentration that stands then is transmitted as read-out measurement concentration.

7.2 Address map

For details of functions and settable ranges of different parameters, refer to the instruction manual for the analyzer.

Word data [read-out/write-in]: Function code [03_H, 06_H, 10_H]

User settings

Relative address	Register No.	Data type	Memory contents	Read-out/write-in data	Remarks or corresponding parameter	Relevant model
0000 _H	40001	Word	CH1 range-1 zero calibration concentration	0 to 9999	Calibration value	R/K
0001 _H	40002	Word	CH1 range-1 span calibration concentration	Decimal point position depends on range		R/K
0002 _H	40003	Word	CH1 range-2 zero calibration concentration			R/K
0003 _H	40004	Word	CH1 range-2span calibration concentration			R/K
0004 _H	40005	Word	CH2 range-1 zero calibration concentration			R/K
0005 _H	40006	Word	CH2 range-1 span calibration concentration			R/K
0006 _H	40007	Word	CH2 range-2 zero calibration concentration			R/K
0007 _H	40008	Word	CH2 range-2 span calibration concentration			R/K
0008 _H	40009	Word	CH3 range-1 zero calibration concentration			R/K
0009 _H	40010	Word	CH3 range-1 span calibration concentration			R/K
000A _H	40011	Word	CH3 range-2 zero calibration concentration			R/K
000B _H	40012	Word	CH3 range-2 span calibration concentration			R/K
000C _H	40013	Word	CH4 range-1 zero calibration concentration			R/K
000D _H	40014	Word	CH4 range-1 span calibration concentration			R/K
000E _H	40015	Word	CH4 range-2 zero calibration concentration			R/K
000F _H	40016	Word	CH4 range-2 span calibration concentration			R/K
0010 _H	40017	Word	CH5 range-1 zero calibration concentration			K
0011 _H	40018	Word	CH5 range-1 span calibration concentration	K		
0012 _H	40019	Word	CH5 range-2 zero calibration concentration	K		
0013 _H	40020	Word	CH5 range-2 span calibration concentration	K		

Word data [read-out/write-in]: Function code [03_H, 06_H, 10_H]

User settings

Relative address	Register No.	Data type	Memory contents	Read-out/write-in data	Remarks or corresponding parameter	Relevant model
0014 _H	40021	Word	CH1 auto calibration switch	0, 1 (0: Do not calibrate in auto calibration 1: Calibrate in auto calibration)	Auto calibration component	R/K
0015 _H	40022	Word	CH2 auto calibration switch			R/K
0016 _H	40023	Word	CH3 auto calibration switch			R/K
0017 _H	40024	Word	CH4 auto calibration switch			R/K
0018 _H	40025	Word	CH5 auto calibration switch			K
0019 _H	40026	Word	CH1 zero calibration switch	0,1 (0: Selectable zero calibration, 1: Zero calibration at once)	About zero calibration	R/K
001A _H	40027	Word	CH2 zero calibration switch			R/K
001B _H	40028	Word	CH3 zero calibration switch			R/K
001C _H	40029	Word	CH4 zero calibration switch			R/K
001D _H	40030	Word	CH5 zero calibration switch			K
001E _H	40031	Word	CH1 calibration range switch	0,1 (0: Calibrate indicated range only, 1: Calibrate both ranges at same time)	About calibration range	R/K
001F _H	40032	Word	CH2 calibration range switch			R/K
0020 _H	40033	Word	CH3 calibration range switch			R/K
0021 _H	40034	Word	CH4 calibration range switch			R/K
0022 _H	40035	Word	CH5 calibration range switch			K
0023 _H	40036	Word	CH1 range-1 high alarm setting	0 to 9999	Alarm setting	R/K
0024 _H	40037	Word	CH1 range-1 low alarm setting	Decimal point position depends on range		R/K
0025 _H	40038	Word	CH1 range-2 high alarm setting			R/K
0026 _H	40039	Word	CH1 range-2 low alarm setting			R/K
0027 _H	40040	Word	CH2 range-1 high alarm setting			R/K
0028 _H	40041	Word	CH2 range-1 low alarm setting			R/K
0029 _H	40042	Word	CH2 range-2 high alarm setting			R/K
002A _H	40043	Word	CH2 range-2 low alarm setting			R/K
002B _H	40044	Word	CH3 range-1 high alarm setting			R/K
002C _H	40045	Word	CH3 range-1 low alarm setting			R/K
002D _H	40046	Word	CH3 range-2 high alarm setting			R/K
002E _H	40047	Word	CH3 range-2 low alarm setting			R/K
002F _H	40048	Word	CH4 range-1 high alarm setting			R/K
0030 _H	40049	Word	CH4 range-1 low alarm setting			R/K
0031 _H	40050	Word	CH4 range-2 high alarm setting			R/K
0032 _H	40051	Word	CH4 range-2 low alarm setting			R/K
0033 _H	40052	Word	CH5 range-1 high alarm setting			K
0034 _H	40053	Word	CH5 range-1 low alarm setting			K
0035 _H	40054	Word	CH5 range-2 high alarm setting			K
0036 _H	40055	Word	CH5 range-2 low alarm setting			K

Word data [read-out/write-in]: Function code [03_H, 06_H, 10_H]

User settings

Relative address	Register No.	Data type	Memory contents	Read-out/write-in data	Remarks or corresponding parameter	Relevant model	
0037 _H	40056	Word	CH1 alarm mode	0,1,2,3,4 (0: High limit alarm, 1: Low limit alarm, 2: High or low limit) 3: High-high limit alarm, 4: Low-low limit alarm	Alarm setting	R/K	
0038 _H	40057	Word	CH2 alarm mode			R/K	
0039 _H	40058	Word	CH3 alarm mode			R/K	
003A _H	40059	Word	CH4 alarm mode			R/K	
003B _H	40060	Word	CH5 alarm mode			K	
003C _H	40061	Word	CH1 alarm switch			0,1 (0: Alarm OFF, 1: Alarm ON)	R/K
003D _H	40062	Word	CH2 alarm switch				R/K
003E _H	40063	Word	CH3 alarm switch				R/K
003F _H	40064	Word	CH4 alarm switch				R/K
0040 _H	40065	Word	CH5 alarm switch				K
0041 _H	40066	Word	Alarm hysteresis	0000H to 0014H (0 to 20%FS)	R/K		
0042 _H	40067	Word	Auto calibration start time(day)	00H to 06H (Sun. to Sat.)	Setting of auto calibration	R/K	
0043 _H	40068	Word	Auto calibration start time(hour)	00H to 23H (BCD code)		R/K	
0044 _H	40069	Word	Auto calibration start time(min)	00H to 59H (BCD code)		R/K	
0045 _H	40070	Word	Auto calibration cycle			R/K	
0046 _H	40071	Word	Auto calibration cycle unit	0,1 (0: h, 1: days)		R/K	
0047 _H	40072	Word	Auto calibration switch	0,1 (0: OFF, 1: ON)		R/K	
0048 _H	40073	Word	Auto calibration gas flow time	003CH to 0257H (60 to 599 sec)		R/K	
0049 _H	40074	Word	Key lock switch	0,1 (0: OFF, 1: ON)	Key lock	R/K	
004A _H	40075	Word	Remote range switch	0,1 (0: OFF, 1: ON)	Remote range	R/K	
004B _H	40076	Word	Response time 1	0000H to 0063H (0 to 99 sec) *(a)	Response time	R/K	
004C _H	40077	Word	Response time 2			R/K	
004D _H	40078	Word	Response time 3			R/K	
004E _H	40079	Word	Response time 4			K	
004F _H	40080	Word	Response time 5			K	
0050 _H	40081	Word	Response time 6			K	
0051 _H	40082	Word	Response time 7			K	
0052 _H	40083	Word	Response time 8			K	
0053 _H	40084	Word	Oxygen meter response time			R/K	
0054 _H	40085	Word	1st order moving average period			0000H to 003bH (0 to 59 min or 1 to 4 h)	Average period
0055 _H	40086	Word	2nd order moving average period	R/K			
0056 _H	40087	Word	3rd order moving average period	R/K			
0057 _H	40088	Word	4th order moving average period	K			
0058 _H	40089	Word	1st order moving average period unit	0,1 (0: h, 1: min)		R/K	
0059 _H	40090	Word	2nd order moving average period unit			R/K	
005A _H	40091	Word	3rd order moving average period unit			R/K	
005B _H	40092	Word	4th order moving average period unit			K	

note) 3

note) 3

Word data [read-out/write-in]: Function code [03_H, 06_H, 10_H]

User settings

Relative address	Register No.	Data type	Memory contents	Read-out/write-in data	Remarks or corresponding parameter	Relevant model
005C _H	40093	Word	Hold switch	0,1 (0: OFF, 1: ON)	Output hold	R/K
005D _H	40094	Word	Oxygen conversion reference value	01H to 13H(1% to 19%)	Oxygen conversion reference value	R/K
005E _H	40095	Word	Peak alarm switch	0,1 (0: OFF, 1: ON)	Setting of peak alarm	
005F _H	40096	Word	Peak alarm concentration	0064H to 03e8H (100 to 1000ppm)		
0060 _H	40097	Word	Peak alarm count	0001H to 0063H (1 to 99 times)		R/K
0061 _H	40098	Word	Peak alarm hysteresis	0000H to 0014H (0 to 20%FS)		R/K
0062 _H	40099	Word	Auto zero calibration start (day)	00H to 06H (Sun. to Sat.)	Setting of auto zero calibration	R/K
0063 _H	40100	Word	Auto zero calibration start (hour)	00H to 23H (BCD code)		R/K
0064 _H	40101	Word	Auto zero calibration start (min)	00H to 59H (BCD code)		R/K
0065 _H	40102	Word	Auto zero calibration cycle			R/K
0066 _H	40103	Word	Auto zero calibration cycle unit	0,1 (0: h, 1: days)		R/K
0067 _H	40104	Word	Auto zero calibration switch	0,1 (0: OFF, 1: ON)		R/K
0068 _H	40105	Word	Auto zero calibration gas flow time	003CH to 0257H (60 to 599 sec)		R/K
0069 _H	40106	Word	CH1 range change setting	0,1 (0: range-1, 1: range-2)	Range changeover (disabled if remote range ON)	R/K
006A _H	40107	Word	CH2 range change setting			R/K
006B _H	40108	Word	CH3 range change setting			R/K
006C _H	40109	Word	CH4 range change setting			R/K
006D _H	40110	Word	CH5 range change setting			K
006E _H	40111	Word	Ch1 range change method			0,1,2 (0:manual, 1:remote, 2:auto)
006F _H	40112	Word	Ch2 range change method		3	
0070 _H	40113	Word	Ch3 range change method		3	
0071 _H	40114	Word	Ch4 range change method		3	
0072 _H	40115	Word	Ch5 range change method		3	
0073 _H	40116	Word	Ch1 auto calibration range	0,1 (0:range-1, 1:range-2)		
0074 _H	40117	Word	Ch2 auto calibration range			3
0075 _H	40118	Word	Ch3 auto calibration range			3
0076 _H	40119	Word	Ch4 auto calibration range			3
0077 _H	40120	Word	Ch5 auto calibration range			3
0078 _H	40121	Word	Alarm 1 target channel		0,1,2,3,4,5,6	
0079 _H	40122	Word	Alarm 2 target channel			3
007A _H	40123	Word	Alarm 3 target channel			3
007B _H	40124	Word	Alarm 4 target channel			3
007C _H	40125	Word	Alarm 5 target channel			3
007D _H	40126	Word	Alarm 6 target channel			3
007E _H	40127	Word	alarm-6 range-1 high alarm setting	0 to 9999		Alarm-6 setting
007F _H	40128	Word	alarm-6 range-1 low alarm setting	Decimal point position	3	
0080 _H	40129	Word	alarm-6 range-2 high alarm setting	depends on range	3	
0081 _H	40130	Word	alarm-6 range-2 low alarm setting		3	

Word data [read-out/write-in]: Function code [03_H, 06_H, 10_H]

User settings

Relative address	Register No.	Data type	Memory contents	Read-out/write-in data	Remarks or corresponding parameter	Relevant model
0082 _H	40131	Word	alarm-6 alarm mode	same as alarm Ch1 to 5		3
0083 _H	40132	Word	alarm-6 alarm switch	same as alarm Ch1 to 5		3
0084 _H	40133	Word	auto calibration gas flow time 1	003Ch to 0384H (60 to 900 sec)		3
0085 _H	40134	Word	auto calibration gas flow time 2			3
0086 _H	40135	Word	auto calibration gas flow time 3			3
0087 _H	40136	Word	auto calibration gas flow time 4			3
0088 _H	40137	Word	auto calibration gas flow time 5			3
0089 _H	40138	Word	auto calibration gas flow time 6			3
008A _H	40139	Word	auto calibration gas flow time 7			3
008B _H	40140	Word	Hold change	(0: Last value, 1: Setting)		3
008C _H	40141	Word	Ch1 hold set value	0 to 100 (%FS)		3
008D _H	40142	Word	Ch2 hold set value			3
008E _H	40143	Word	Ch3 hold set value			3
008F _H	40144	Word	Ch4 hold set value			3
0090 _H	40145	Word	Ch5 hold set value			3
0091 _H	40146	Word	Blowback start (day)	00H to 06H (Sun. to Sat.)	Blowback setting (Option)	3
0092 _H	40147	Word	Blowback start (hour)	00H to 23H (BCD code)		3
0093 _H	40148	Word	Blowback start (min)	00H to 59H (BCD code)		3
0094 _H	40149	Word	Blowback cycle	1 to 99 (h), 1 to 7 (days)		3
0095 _H	40150	Word	Blowback cycle unit	0,1 (0:h, 1:days)		3
0096 _H	40151	Word	Blowback switch	0,1 (0:OFF, 1:ON)		3
0097 _H	40152	Word	Gas displacement time after blowback	003Ch to 0384H (60 to 900 sec)		3
0098 _H	40153	Word	Measurement point change cycle	1 to 60 (min), 1 to 99 (h)	Measurement point change setting (Option)	3
0099 _H	40154	Word	Measurement point change cycle unit	0,1 (0:min, 1:h)		3
009A _H	40155	Word	Measurement point change displacement time	003Ch to 0384H (60 to 900 min)		3
009B _H	40156	Word	Measurement point change setting	0,1,2 (0: Line 1, 1: Line 2, 2: Change)		3

Word data [write-in] : Function code [06_H]**Operation command**

Relative address	Register No.	Data type	Memory contents	Write-in data	Remarks or corresponding parameter	Relevant model
07D0 _H	42001	Word	Keying command	01H:MODE 02H: Side, 04H: Up, 08H: Down 10H: ESC, 20H: ENT 40H: ZERO, 80H: SPAN	Sending a value simulates keying	R/K
07D1 _H	42002	Word	Display change	1: Return to measurement mode display	Force to return to measurement mode	R/K
07D2 _H	42003	Word	Auto calibration	1; Execute auto calibration	Auto calibration is executed only once.	3/5
07D3 _H	42004	Word	Auto zero calibration	1; Execute auto zero calibration	Auto zero calibration is executed only once.	3/5
07D4 _H	42005	Word	Blowback	1; Execute blowback	Blowback is executed only once. (Option)	3

Word data [read-out only] : Function code[04_H]

Measurement value and status

Relative address	Register No.	Data type	Memory contents	Read-out data	Remarks or corresponding parameter	Relevant model
0000 _H	30001	Word	CH1 concentration	Concentration: -9999 to 9999 (value corresponding to indication without decimal point) Decimal point position: 0,1,2,3 (0; concentration/1 1; concentration/10 2; concentration/100 3; concentration/1000) Measurement unit: 0, 1, 2, 3 (0; vol% 1; ppm 2; mg/m ³ 3; g/m ³) Transmit values under current measurement conditions		R/K
0001 _H	30002	Word	CH1 decimal point position			R/K
0002 _H	30003	Word	CH1 measurement unit			R/K
0003 _H	30004	Word	CH2 concentration			R/K
0004 _H	30005	Word	CH2 decimal point position			R/K
0005 _H	30006	Word	CH2 measurement unit			R/K
0006 _H	30007	Word	CH3 concentration			R/K
0007 _H	30008	Word	CH3 decimal point position			R/K
0008 _H	30009	Word	CH3 measurement unit			R/K
0009 _H	30010	Word	CH4 concentration			R/K
000A _H	30011	Word	CH4 decimal point position			R/K
000B _H	30012	Word	CH4 measurement unit			R/K
000C _H	30013	Word	CH5 concentration			R/K
000D _H	30014	Word	CH5 decimal point position			R/K
000E _H	30015	Word	CH5 measurement unit			R/K
000F _H	30016	Word	CH6 concentration			R/K
0010 _H	30017	Word	CH6 decimal point position			R/K
0011 _H	30018	Word	CH6 measurement unit			R/K
0012 _H	30019	Word	CH7 concentration			R/K
0013 _H	30020	Word	CH7 decimal point position			R/K
0014 _H	30021	Word	CH7 measurement unit			R/K
0015 _H	30022	Word	CH8 concentration			R/K
0016 _H	30023	Word	CH8 decimal point position			R/K
0017 _H	30024	Word	CH8 measurement unit			R/K
0018 _H	30025	Word	CH9 concentration			K
0019 _H	30026	Word	CH9 decimal point position			K
001A _H	30027	Word	CH9 measurement unit			K
001B _H	30028	Word	CH10 concentration			K
001C _H	30029	Word	CH10 decimal point position			K
001D _H	30030	Word	CH10 measurement unit			K
001E _H	30031	Word	CH11 concentration			K
001F _H	30032	Word	CH11 decimal point position			K
0020 _H	30033	Word	CH11 measurement unit			K
0021 _H	30034	Word	CH12 concentration	K		
0022 _H	30035	Word	CH12 decimal point position	K		
0023 _H	30036	Word	CH12 measurement unit	K		

Word data [read-out only] : Function code[04_H]

Measurement value and status

Relative address	Register No.	Data type	Memory contents	Read-out data	Remarks or corresponding parameter	Relevant model
0024 _H	30037	Word	Peak count	0 to 100 times/hour		R/K
0025 _H	30038	Word	CH1 current range	0, 1 (0; range-1, 1;range-2)		R/K
0026 _H	30039	Word	CH2 current range			R/K
0027 _H	30040	Word	CH3 current range			R/K
0028 _H	30041	Word	CH4 current range			R/K
0029 _H	30042	Word	CH5 current range			K
002A _H	30043	Word	CH1 high/low limit alarm	0, 1, 2, 3, 4 (0: No alarm, 1: High limit alarm, 2: Low limit alarm 3: High-high limit alarm, 4: Low-low limit alarm	Whether or how alarm is currently produced.	R/K
002B _H	30044	Word	CH2 high/low limit alarm			R/K
002C _H	30045	Word	CH3 high/low limit alarm			R/K
002D _H	30046	Word	CH4 high/low limit alarm			R/K
002E _H	30047	Word	CH5 high/low limit alarm			K
002F _H	30048	Word	Peak count alarm	0,1 (0: No, 1: Yes)		R/K
0030 _H	30049	Word	Auto (Auto zero) calibration in progress	0,1 (0: No, 1: Yes)		R/K
0031 _H	30050	Word	CH1 zero calibration in progress	0,1 (0: No, 1: Yes)		R/K
0032 _H	30051	Word	CH2 zero calibration in progress			R/K
0033 _H	30052	Word	CH3 zero calibration in progress			R/K
0034 _H	30053	Word	CH4 zero calibration in progress			R/K
0035 _H	30054	Word	CH5 zero calibration in progress			K
0036 _H	30055	Word	CH1 span calibration in progress			R/K
0037 _H	30056	Word	CH2 span calibration in progress			R/K
0038 _H	30057	Word	CH3 span calibration in progress			R/K
0039 _H	30058	Word	CH4 span calibration in progress			R/K
003A _H	30059	Word	CH5 span calibration in progress			K
003B _H	30060	Word	Instrument error	0,1 (0: No, 1; Yes)	Whether error is produced	R/K
003C _H	30061	Word	Calibration error	0,1 (0: No, 1; Yes)	Whether error is produced	R/K
003D _H	30062	Word	Latest error No.	-1 to 9 (Error No.-1) * (b) 0 to 6 (Sun. to Sat.) 0 to 23 (hours) 0 to 59 (min) 0 to 4	Error log contents (Date of the month appears in the WEEK data field with improved ZKJ version 3.)	R/K
003E _H	30063	Word	Latest error WEEK			R/K
003F _H	30064	Word	Latest error HOUR			R/K
0040 _H	30065	Word	Latest error MIN			R/K
0041 _H	30066	Word	Latest error TARGET			R/K

Word data [read-out only] : Function code[04_H]

Measurement value and status

Relative address	Register No.	Data type	Memory contents	Read-out data	Remarks or corresponding parameter	Relevant model
0042 _H	30067	Word	The previous error No.	-1 to 9 (Error No.-1)		R/K
0043 _H	30068	Word	The previous error WEEK	0 to 6 (Sun. to Sat.)		R/K
0044 _H	30069	Word	The previous error HOUR	0 to 23 (hours)		R/K
0045 _H	30070	Word	The previous error MIN	0 to 59 (min)		R/K
0046 _H	30071	Word	The previous error TARGET	0 to 4		R/K
						R/K
						R/K
007E _H	30127	Word	Oldest error No.	-1 to 9 (Error No.-1)		R/K
007F _H	30128	Word	Oldest error WEEK	0 to 6 (Sun. to Sat.)		R/K
0080 _H	30129	Word	Oldest error HOUR	0 to 23 (hour)		R/K
0081 _H	30130	Word	Oldest error MIN	0 to 59 (min)		R/K
0082 _H	30131	Word	Oldest error TARGET	0 to 4		R/K
0083 _H	30132	Word	Error 1	0,1 (0: No, 1: Yes)	Whether error is currently produced	R/K
0084 _H	30133	Word	Error 2			R
0085 _H	30134	Word	Error 3			R
0086 _H	30135	Word	Error 10			R/K
0087 _H	30136	Word	CH1 Error 4	0,1 (0: No, 1: Yes)		R/K
0088 _H	30137	Word	CH1 Error 5			R/K
0089 _H	30138	Word	CH1 Error 6			R/K
008A _H	30139	Word	CH1 Error 7			R/K
008B _H	30140	Word	CH1 Error 8			R/K
008C _H	30141	Word	CH1 Error 9		R/K	
						R/K
						R/K
0099 _H	30154	Word	CH4 Error 4	0,1 (0: No, 1: Yes)		R/K
009A _H	30155	Word	CH4 Error 5			R/K
009B _H	30156	Word	CH4 Error 6			R/K
009C _H	30157	Word	CH4 Error 7			R/K
009D _H	30158	Word	CH4 Error 8			R/K
009E _H	30159	Word	CH4 Error 9		R/K	
009F _H	30160	Word	CH5 Error 4	0,1 (0: No, 1: Yes)		K
00A0 _H	30161	Word	CH5 Error 5			K
00A1 _H	30162	Word	CH5 Error 6			K
00A2 _H	30163	Word	CH5 Error 7			K
00A3 _H	30164	Word	CH5 Error 8			K
00A4 _H	30165	Word	CH5 Error 9		K	

Word data [read-out only] : Function code[04_H]

Measurement value and status

Relative address	Register No.	Data type	Memory contents	Read-out data	Remarks or corresponding parameter	Relevant model
00A5 _H	30166	Word	CH1 auto zero calibration in progress	0,1 (0: No, 1: Yes)		R/K
00A6 _H	30167	Word	CH1 auto span calibration in progress			R/K
00A7 _H	30168	Word	CH1 hold in progress	0,1 (0: No, 1: Yes)		R/K
						R/K
						R/K
00AE _H	30175	Word	CH4 auto zero calibration in progress	0,1 (0: No, 1: Yes)		R/K
00AF _H	30176	Word	CH4 auto span calibration in progress			R/K
00B0 _H	30177	Word	CH4 hold in progress	0,1 (0: No, 1: Yes)		R/K
00B1 _H	30178	Word	CH5 auto zero calibration in progress	0,1 (0: No, 1: Yes)		K
00B2 _H	30179	Word	CH5 auto span calibration in progress			K
00B3 _H	30180	Word	CH5 hold in progress	0,1 (0: No, 1: Yes)		K
00B4 _H	30181	Word	Display information (1)	* (c)		R/K
00B5 _H	30182	Word	Display information (2)			R/K
00B6 _H	30183	Word	Display information (3)			R/K
00B7 _H	30184		(Do not use)			
00B8 _H	30185		(Do not use)			
00B9 _H	30186		(Do not use)			
00BA _H	30187		(Do not use)			
00BB _H	30188		(Do not use)			
00BC _H	30189	Word	Manual calibration channel	Cursor CH-1 * (d)		R/K
00BD _H	30190		(Do not use)			
00BE _H	30191	Word	High/Low limit alarm (6)			3
00BF _H	30192		(Do not use)			
00C0 _H	30193		(Do not use)			
00C1 _H	30194		(Do not use)			

Word data [read-out only] : Fuction code[04_H]

Fixed setting

Relative address	Register No.	Data type	Memory contents	Read-out data	Remarks or corresponding parameter	Relevant model
0425 _H	31062	Word	CH1 range numbers	1, 2		R/K
0426 _H	31063	Word	CH2 range numbers	(1: 1 range, 2: 2 ranges)		R/K
0427 _H	31064	Word	CH3 range numbers		R/K	
0428 _H	31065	Word	CH4 range numbers		R/K	
0429 _H	31066	Word	CH5 range numbers		K	
042A _H	31067	Word	CH1 range-1 unit		0,1,2,3	
042B _H	31068	Word	CH1 range-2 unit	(0;vol%		R/K
042C _H	31069	Word	CH2 range-1 unit	1; ppm		R/K
042D _H	31070	Word	CH2 range-2 unit	2; mg/m3		R/K
042E _H	31071	Word	CH3 range-1 unit	3; g/m3)		R/K
042F _H	31072	Word	CH3 range-2unit		R/K	
0430 _H	31073	Word	CH4 range-1 unit		R/K	
0431 _H	31074	Word	CH4 range-2 unit		R/K	
0432 _H	31075	Word	CH5 range-1 unit		K	
0433 _H	31076	Word	CH5 range-2 unit	K		K
0434 _H	31077	Word	CH1 range-1 value	1 to 9999	With improved ZKJ version 3, the actual range value is calculated with the decimal point position taken into consideration. Actual range value = Read range value / X (X is 1 when 0 is selected, 10 when 1 is selected, and 100 when 2 is selected, and 1000 when 3 is selected for decimal point position.)	R/K
0435 _H	31078	Word	CH1 range-2 value			R/K
0436 _H	31079	Word	CH2 range-1 value			R/K
0437 _H	31080	Word	CH2 range-2 value			R/K
0438 _H	31081	Word	CH3 range-1 value			R/K
0439 _H	31082	Word	CH3 range-2 value			R/K
043A _H	31083	Word	CH4 range-1 value			R/K
043B _H	31084	Word	CH4 range-2 value			R/K
043C _H	31085	Word	CH5 range-1 value			K
043D _H	31086	Word	CH5 range-2 value	K		
043E _H	31087	Word	CH1 range-1 decimal point position	0,1,2,3		R/K
043F _H	31088	Word	CH1 range-2 decimal point position	(0: Nothing below decimal point, 1: 1 digit below decimal point, 2: 2 digits below decimal point, 3: 3 digits below decimal point.		R/K
0440 _H	31089	Word	CH2 range-1 decimal point position		R/K	
0441 _H	31090	Word	CH2 range-2 decimal point position		R/K	
0442 _H	31091	Word	CH3 range-1 decimal point position		R/K	
0443 _H	31092	Word	CH3 range-2 decimal point position		R/K	
0444 _H	31093	Word	CH4 range-1 decimal point position		R/K	
0445 _H	31094	Word	CH4 range-2 decimal point position		R/K	
0446 _H	31095	Word	CH5 range-1 decimal point position		K	
0447 _H	31096	Word	CH5 range-2 decimal point position		K	

Word data [read-out only] : Fuction code[04_H]

Fixed setting

Relative address	Register No.	Data type	Memory contents	Read-out data	Remarks or corresponding parameter	Relevant model
0448 _H	31097	Word	Type: first digit	Z		3/5
0449 _H	31098	Word	Type: second digit	K or R		3/5
044A _H	31099	Word	Type: third digit	J		3/5
044B _H	31100	Word	Type: fourth digit	0 to 9, A to Z		3/5
044C _H	31101	Word	Type: fifth digit	0 to 9, A to Z		3/5
044D _H	31102	Word	Type: sixth digit	0 to 9, A to Z		3/5
044E _H	31103	Word	Type: seventh digit	0 to 9, A to Z		3/5
044F _H	31104	Word	Type: eights digit	3 or 5		3/5
0450 _H	31105	Word	Type: ninth digit	0 to 9, A to Z		3/5
0451 _H	31106	Word	Type: tenth digit	0 to 9, A to Z		3/5
0452 _H	31107	Word	Type: eleventh digit	0 to 9, A to Z		3/5
0453 _H	31108	Word	Type: twelfth digit	0 to 9, A to Z		3/5
0454 _H	31109	Word	Type: thirteenth digit	0 to 9, A to Z		3/5
0455 _H	31110	Word	Type: fourteenth digit	0 to 9, A to Z		3/5
0456 _H	31111	Word	Type: fifteenth digit	0 to 9, A to Z		3/5
0457 _H	31112	Word	Type: sixteenth digit	0 to 9, A to Z		3/5
0458 _H	31113	Word	Type: seventeenth digit	0 to 9, A to Z		3/5
0459 _H	31114	Word	Type: eighteenth digit	0 to 9, A to Z		3/5
045A _H	31115	Word	Type: nineteenth digit	0 to 9, A to Z		3/5
045B _H	31116	Word	Type: twentieth digit	0 to 9, A to Z		3/5
045C _H	31117	Word	Type: twenty first digit	0 to 9, A to Z		3/5
045D _H	31118	Word	Type: twenty second digit	0 to 9, A to Z		3/5
045E _H	31119	Word	Type: twenty third digit	0 to 9, A to Z		3
045F _H	31120	Word	Type: twenty fourth digit	0 to 9, A to Z		3
0460 _H	31121	Word	Board: first digit	0 to 9, A to Z		3/5
0461 _H	31122	Word	Board: second digit	0 to 9, A to Z		3/5
0462 _H	31123	Word	Board: third digit	0 to 9, A to Z		3/5
0463 _H	31124	Word	Board: fourth digit	0 to 9, A to Z		3/5
0464 _H	31125	Word	Board: fifth digit	0 to 9, A to Z		3/5
0465 _H	31126	Word	Board: sixth digit	0 to 9, A to Z		3/5
0466 _H	31127	Word	Board: seventh digit	0 to 9, A to Z		3/5
0467 _H	31128	Word	Board: eights digit	0 to 9, A to Z		3/5

Notes

1. Relevant model: R: ZRJ, K: ZKJ.
For data for which only K or R is indicated, there is no data for the other model.
The addresses marked with "3" is used for improved ZKJ version 3 only.
The addresses marked with "3/5" is used for improved ZKJ version 3 and improved ZRJ version 5 only.
2. For contents of *(a) to *(d), refer to Section 7.3 "Supplements to address map".
3. There is no date improved ZKJ version 3.

7.3 Supplement to address map

* (a) Register No. 40076 to 40083 (response time 1 to 8)

The following shows signals corresponding to response time 1 to 8.

- ZRJ

Response time 1	1st component detector signal
Response time 2	2nd component detector signal
Response time 3	3rd component detector signal
Response time 4 to 8	Unused

The above does not include sensor signals of oxygen.

- ZKJ

Response time 1	1st component measurement detector signal
Response time 2	1st component interference compensation detector signal
Response time 3	2nd component measurement detector signal
Response time 4	2nd component interference compensation detector signal
Response time 5	3rd component measurement detector signal
Response time 6	3rd component interference compensation detector signal
Response time 7	4th component measurement detector signal
Response time 8	4th component interference compensation detector signal

The above does not include sensor signals of oxygen.

* (b) Register No. 30062 to 30131 (error log)

Up to 14 errors logged can be read in the order from the latest to older ones.

The contents are as follows.

Error No.: No. of produced error. Stored value is error number minus 1.

Error WEEK: Day when error occurred.

Error HOUR: Indicates at what o'clock error occurred.

Error MIN: Indicates at what minutes error occurred.

Error TARGET: No. of CH where error occurred.

CH No. minus 1 is stored.

0 at error No. 1, 2, 3 or 10.

No. of optical system where error occurred minus 1 if error No. is 1 in case of ZKJ.

* (c) Register numbers 30181, 30182, 30183 (display information (1), (2), (3))

The display information is values for knowing the current display status of the instrument.

- Contents of values of display information (1) (status of each setting panel)

- 0: Measurement mode display (manual calibration display included)

- 1: Menu mode display

- 2: Changeover of range display

- 3: Calibration setting display

- 4: Alarm setting display

- 5: Automatic calibration setting display

- 6: Peak alarm setting display

- 7: Parameter setting display

- 8: Maintenance mode display

- 9: Factory mode display

- 10: Auto zero calibration setting display

- Contents of values of display information (2) (status at manual calibration)

- 0: Measurement mode display

- 4: Channel selection display at manual zero calibration

- 5: Zero calibration wait display at manual zero calibration

- 6: Zero calibration in progress display at manual zero calibration

- 7: Channel selection display at manual span calibration

- 8: Span calibration wait display at manual span calibration

- 9: Span calibration in progress display at manual span calibration

- 10: Error contents indication display

- Contents of values of display information (3)

- Correspond to value of CH (channel) from which the measurement mode is displayed.

- Top channel number minus 1 is stored.

* (d) Register number 30189 (manual calibration channel)

Data for knowing a channel (component) which the cursor is positioned at to carry out a calibration at when a manual calibration is under way.

Channel number to carry out a calibration at minus 1 is stored.

8. TROUBLESHOOTING

If the communication is unavailable, check the following items.

- Whether all devices related to communication are turned on.
- Whether connections are correct.
- Whether the number of connected instruments and connection distance are as specified
- Whether communication conditions coincide between the master station (host computer) and slave stations (instrument)
 - Transmission speed : 9600bps
 - Data length : 8 bits
 - Stop bit : 1 bit
 - Parity : None

- Whether send/receive signal timing conforms to Section 5.6 in this manual.
- Whether the station No. designated as send destination by the master station coincides with the station No. of the connected instrument.
- Whether more than one instrument connected on the same transmission line shares the same station No.
- Whether the station No. of instruments is set at other than 0.
If it's 0, the communication function does not work.

Fuji Electric Co., Ltd.

International Sales Div

Sales Group

Gate City Ohsaki, East Tower, 11-2, Osaki 1-chome,
Shinagawa-ku, Tokyo 141-0032, Japan

<http://www.fujielectric.com>

Phone: 81-3-5435-7280, 7281 Fax: 81-3-5435-7425

<http://www.fujielectric.com/products/instruments/>
