



Instruction Manual

ULTRASONIC FLOWMETER DETECTOR

TYPE: FSS (Detector)

FLY (Signal cable)

<Transmitter: For FLR-3, FSV-2>

INTRODUCTION

We thank you very much for purchasing Fuji Electric's ultrasonic flow meter. The instruction manual concerns the installation, operation, checkup and maintenance of the Ultrasonic flow meter, Detector (FSS) and Signal cable (FLY) of ultrasonic flow meter. Read it carefully before operation.

- First read this instruction manual carefully until an adequate understanding is acquired, and then proceed to installation, operation and maintenance of the flow meter. Improper handling may result in an accident or a failure.
- The specifications of this flow meter are subject to change without prior notice for improvement of the product.
- Do not attempt to modify the flow meter without permission. Fuji will not bear any responsibility for a trouble caused by such a modification. If it becomes necessary to modify the flow meter, contact our office in advance.
- This instruction manual should always be kept on hand by the operator.
- After reading the manual, be sure to store it at a place easier to access.
- This instruction manual should be delivered to the end user.
- If the instruction manual has been lost, request another one (with charge) to our local business office.

Manufacturer:	Fuji Electric Co., Ltd.
Type:	Described in the nameplate put on the main body
Date of manufacture:	Described in the nameplate put on the main body
Product nationality:	Japan

Note

- Reproduction of any part or the whole of this manual without permission is strictly prohibited by laws.
- Contents of the manual are subject to change without prior notice.

©Fuji Electric Co., Ltd. 2012

Issued in Dec., 2012
Rev. 1st edition, Dec., 2012
Rev. 2nd edition, Feb., 2013
Rev. 3rd edition, Jan., 2014
Rev. 4th edition, Nov., 2015
Rev. 5th edition, Jun., 2016

SAFETY PRECAUTIONS

Before using this product, read the following safety precautions and use the product correctly.

The following items are important for safe operation and must be fully observed. These safety precautions are ranked in 2 levels; "DANGER" and "CAUTION".

Warning/Symbol	Meaning
DANGER	Incorrect handling of the device may result in death or serious injury.
CAUTION	Incorrect handling may lead to a risk of medium or light injury, or to a risk of physical damage.

The items noted under " CAUTION " may also result in serious trouble depending on circumstances. All the items must be fully observed.

Caution on mounting and piping	
DANGER	<ul style="list-style-type: none"> ● This unit is not explosion-proof type. Do not use it in a place with explosive gases. Otherwise, it may result in serious accidents such as explosion, fire, etc.
CAUTION	<ul style="list-style-type: none"> ● The unit should be installed in a place conforming to the installation requirements noted in this instruction manual. Otherwise, it may cause electric shocks, fire or malfunction of the unit. ● Install the flow meter according to the following steps to prevent it from damage, and to avoid error or malfunction. ● During installation, make sure that the inside of the unit is free from cable chips and other foreign objects. Otherwise, it may cause fire, failure or malfunction. ● The items under "Caution on Installation" noted in the manual must be fully observed. Careless installation may result in trouble or malfunction of the unit.

Caution on wiring	
CAUTION	<ul style="list-style-type: none"> ● Before performing the wiring work, be sure to turn OFF the main power. Otherwise, it may cause electric shock. ● Do not perform wiring work outdoors in rainy days to prevent insulation deterioration and dew condensation. Otherwise, it may result in trouble, malfunction, etc. ● Be sure to connect a power source of correct rating. Use of power source out of rating may cause fire. ● The unit must be grounded as specified. Otherwise, it may cause electric shocks, malfunction, etc. ● The signal cable should be wired as far as possible from high-voltage lines to prevent from influence of noise as it will cause malfunction of the unit. ● To prevent malfunction of the unit, the signal cable and power cable should be wired using separate conduits.

Caution on maintenance and inspection



CAUTION

- The unit should be inspected every day to always obtain good results of measurements.
- When measuring the insulation resistance of the signal cable, follow the procedure “Section 8. CHECK AND MAINTENANCE” described in this manual.

CAUTION ON INSTALLATION LOCATION



CAUTION

- (1) A place that provides enough space for periodic inspection and wiring work.
- (2) A place not exposed to direct sunshine nor inclement weather.
- (3) A place free from excessive vibration, dust, dirt and moisture.
- (4) A place not subjected to radiated heat from a heating furnace, etc.
- (5) A place not subjected to corrosive atmosphere.
- (6) A place not to be submerged.
- (7) A place remote from electrical devices (motor, transformer, etc.) which generate electromagnetic induction noise, electrostatic noise, etc.
- (8) A place not subjected to excessive fluid pulsation such as pump discharge side.
- (9) A place that provides enough place for the length of the straight pipe.
- (10) A place where ambient temperature and humidity are -20 to +60°C and 90% RH or less for detector (-20 to +60°C and 100% RH or less for detector (FSSE)).

CONTENTS

INTRODUCTION	I	8.2.1. Checking zero point	35
SAFETY PRECAUTIONS	II	8.2.2. Reapplying grease	35
CAUTION ON INSTALLATION LOCATION	IV	9. APPENDIX	36
1. PRODUCT OUTLINE	1	9.1. Specifications	36
1.1. Checking delivered items	1	9.2. Outline diagram	38
1.2. Check on type and specifications	2	9.3. Detector for special application	40
1.3. Name and function of each part	5	9.4. How to make gauge paper	43
1.3.1. Type FSSA	5		
1.3.2. Type FSSC	5		
1.3.3. Type FSSE	6		
1.3.4. Type FSSD, FSSH	7		
2. INSTALLATION	8		
2.1. Detector mounting procedure	9		
2.2. Selection of mounting position	10		
2.3. Length of straight pipe	12		
2.4. Selection of mounting method	13		
2.5. Mounting of detector	14		
2.5.1. Image figure of mounting dimension	14		
2.6. Processing of mounting surface	15		
2.7. How to determine the mounting position	16		
2.8. Selection of acoustic coupler	17		
2.9. Signal cable end treatment	18		
2.9.1. Signal cable end treatment for type FLYA (For FLR-3)	18		
2.9.2. Signal Cable end treatment for type FLYD (For FSV-2)	18		
3. MOUNTING OF FSSA TYPE	19		
3.1. Frame mounting method	19		
3.2. Mounting of sensor unit	20		
4. MOUNTING OF FSSC TYPE	22		
4.1. Mounting for V method	22		
4.2. Mounting for Z method	25		
4.3. Method of mounting belt	27		
5. MOUNTING OF FSSE TYPE	30		
5.1. Connection of sensor cable	30		
5.2. Mounting method on the pipe	31		
6. MOUNTING OF FSSD TYPE	32		
7. MOUNTING OF FSSH TYPE	33		
7.1. Mounting of detector (in case of V method)	33		
7.2. Mounting of detector (in case of Z method)	34		
8. CHECK AND MAINTENANCE	35		
8.1. Daily Check	35		
8.2. Periodic Inspection	35		

1. PRODUCT OUTLINE

1.1. Checking delivered items

After opening the package, check if all following parts are present.

Note that the delivered parts vary according to the model type.

<Detector> 4th digit of code symbol

- FSSA: Flame 1 piece
- Sensor units 2 pieces
- FSSC: Rail 1 set
- Sensor unit 2 pieces
- Rail-end as standard 2 pieces
- FSSD: Flame 1 set
- Sensor unit 2 pieces
- FSSE: Sensor unit 2 pieces
- Conversion cord 2 pieces
- FSSH: Rail 1 piece
- Sensor unit 2 pieces

<Mounting belt> 6th digit of code symbol FSS**□

















- A: Stainless steel belt 2 pieces
- B: Velcro band (3m) 1 piece
- C: SUS belt fasten with screw 4 pieces
- D: Wire rope
 (5m x 2pieces, Mounting spring x 2pieces) 2sets
- E: Wire rope
 (20m x 2pieces, Mounting spring x 2pieces) 2sets

<Acoustic coupler> 7th digit of code symbol FSS***□

- A: Silicone rubber 1 piece
- B: Silicone-free grease 1 piece
- C: Silicone grease 1 piece
- D: Silicone grease for high temperature 1 piece

<Signal cable>

- FLYA (length specified) 2 pieces
- FLYD (length specified) 2 pieces

Detector	Mounting belt	Acoustic coupler	Signal cable
<p>FSSA</p> 	<p>Stainless steel belt</p> 	<p>Silicone rubber</p> 	<p>FLYA</p> 
<p>FSSC</p> 	<p>Velcro band</p> 	<p>Silicone-free grease</p> 	<p>FLYD</p> 
<p>FSSD</p> 	<p>Belt with SUS screw clamp</p> 	<p>Silicone grease</p> 	
<p>FSSE</p> 	<p>Wire rope</p> 	<p>Silicone grease for high temperature</p> 	
<p>Conversion cord</p> 	<p>Mounting spring</p> 		
<p>FSSH</p> 			

1.2. Check on type and specifications

The type and specifications of product are indicated on the specifications plate mounted on the flow transmitter and detector frame.

Check that they represent the type you ordered, referring to the following code symbols.

<Detector (FSSA)common type>

1	2	3	4	5	6	7	8	9	10	Description
F	S	S	A	1	A	1	-	Y		<Senser type> (4th digits) ø25 to ø225mm (V method)
			A							<Guide rall> (5th digits) Provided
				1						<Mounting belt> (6th digits) Stainless belt (1.5m × 2)
					A					<Acoustic coupler> (7th digit) (Note) None Silicon rubber Silicon-free grease
						Y				
						A				
						B				
							Y			
								Y		<Tag plate> (10th digit) None Provided
								A		

Note) Select silicone rubber (A) for the acoustic coupler in ordinary cases. Silicone rubber is supplied in a tube (100g). If two or more instruments are ordered, you can select a tube of silicone rubber for every 5 units. Select silicone-free grease (B) if the instrument is to be used in an environment where generation of silicone is not desirable such as semiconductor manufacturing facilities. The grease, which is soluble in water, should not be used in an environment where water may be splashed onto it or condensation may occur on the surface of the piping. Since it does not harden, periodic maintenance (cleaning and refilling of approximately once every 6 months in room temperature) is required.

FSSA

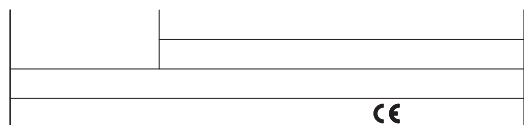

<Detector (FSSC), common type>

1	2	3	4	5	6	7	8	10	11	Description
F	S	S	C	1						<Senser type> (4th digits) ø50 to ø1200mm
			C							
				1						<Guide rail> (5th digits) Provided (Extendable rail type)
					Y					<Mounting belt> (6th digits) *2 None
					A					Stainless belt (1.0m×2)
					C					SS belt fasten with screws (1.0m×4)
					D					Wire ≤ ø1500mm
						Y				<Acoustic coupler> (7th digit) None
						A				Silicon rubber (KE348)
						B				Silicone-free grease (HIGH-Z)
						C				Silicone grease (G40M)
							Y			<Water-proof treatment> (9th digit) None
							A			Provided (with signal cable 10m)
								Y		<Tag plate> (10th digit) None
								A		Provided

*2) Please refer to the table 8 to select the mounting belt at 6th digits.

[Table 8] How to select at 6th digits.

Mounting method	≤ø300mm	≤ø600mm	≤ø1200mm
V method	A or C	C	D
Z method	C	D	D



<Detector (FSSD, FSSE, FSSH) common type>
 Please refer to item 9.3 for special detector

<Signal cable (FLY)>
 For frow transmitter FLR-3

For frow transmitter FSV-2

1	2	3	4	5	6	7	8	Description
F	L	Y					1	Type of sensor (4th digit code) for FSSA, FSSC
			A					Cable length (5, 6 and 7th digit)
				0	0	5		5 m
				0	1	0		10 m
				0	1	5		15 m
				0	2	0		20 m
				0	2	5		25 m
				0	3	0		30 m
				0	4	0		40 m
				0	5	0		50 m
				0	6	0		60 m
				Z	Z	Z		Others (contact us)

1	2	3	4	5	6	7	8	Description
F	L	Y					1	Type of sensor (4th digit) for FSSA, FSSC, FSSD, FSSH, FSSE
			D					Cable length (5,6 and 7th digit)
				0	0	5		5 m
				0	1	0		10 m
				0	1	5		15 m
				0	2	0		20 m
				0	2	5		25 m
				0	3	0		30 m
				0	3	5		35 m
				0	4	0		40 m
				0	4	5		45 m
				0	5	0		50 m
				0	5	5		55 m
				0	6	0		60 m
				0	6	5		65 m
				0	7	0		70 m
				0	7	5		75 m
				0	8	0		80 m
				0	8	5		85 m
				0	9	0		90 m
				0	9	5		95 m
				1	0	0		100 m
				1	1	0		110 m
				1	2	0		120 m
				1	3	0		130 m
				1	4	0		140 m
				1	5	0		150 m
				Z	Z	Z		Others (contact us)

Note: Please order this if "None" is selected for water-proof treatment at code of symbol.

1.3. Name and function of each part

1.3.1. Type FSSA

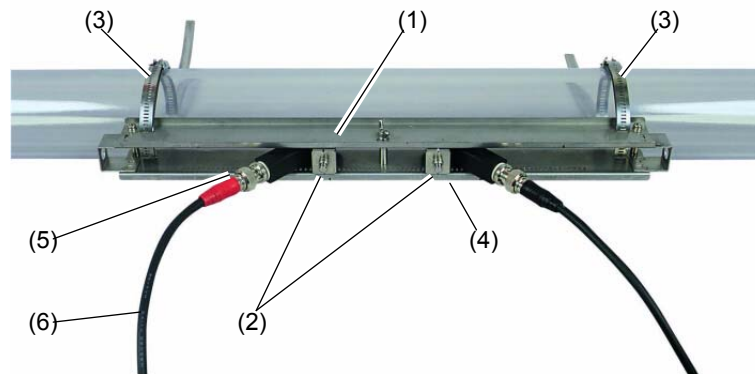

FSSA

No.	Name	Description
(1)	Frame for small size	Fastens the sensor unit on pipe.
(2)	Sensor unit	Sends and receives an ultrasonic wave.
(3)	Stainless steel belt	Fastens the frame on pipe.
(4)	Scale	Reads the sensor mounting spacing.
(5)	Fastening hole	Makes a position and fastens the sensor units.
(6)	Signal cable	Transmits send/receive signals.

1.3.2. Type FSSC

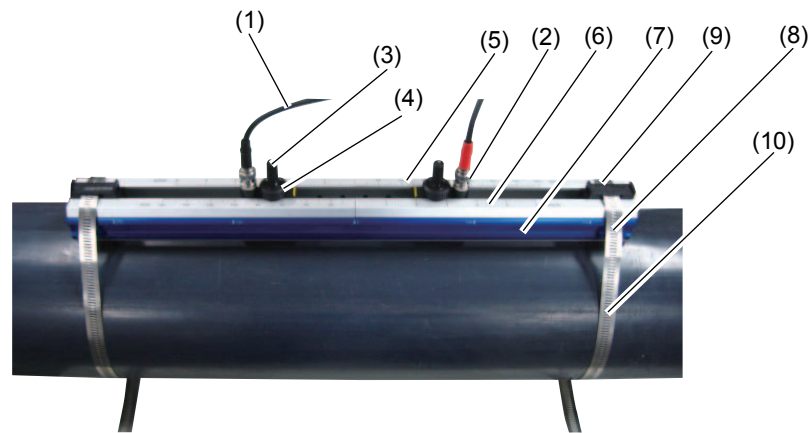

FSSC

No.	Name	Description
(1)	Signal cable	Transmits the sending/receiving signals.
(2)	Sensor unit	Sends and receives an ultrasonic wave
(3)	Element holder	Attaches the sensor unit firmly to the pipe
(4)	Lock nut	Adjusts the sensor unit mounting position
(5)	Scale	Reads the spacing between the sensor units
(6)	Guide rail	Guides the sensor unit
(7)	Extension rail	Connect the two guide rails to extend
(8)	Fixing screw	Fixes the guide rail and extension rail
(9)	Rail-end	Fixes the guide rail and mounting belt
(10)	Stainless steel belt	Fastens the rail on pipe

1.3.3. Type FSSE



FSSE

No.	Name	Description
(1)	Signal cable	Transmits send/receive signals.
(2)	Detector	Sends and receives an ultrasonic wave.
(3)	Wire rope	Fastens the detector on pipe.
(4)	Mounting spring	Removes the play of wire rope.

1.3.4. Type FSSD, FSSH

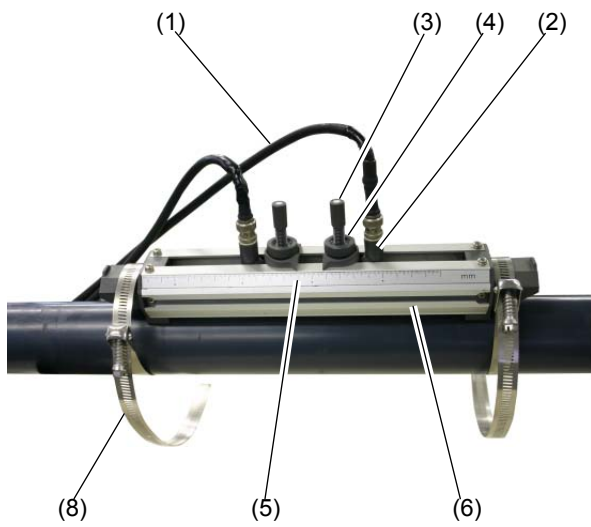

FSSD

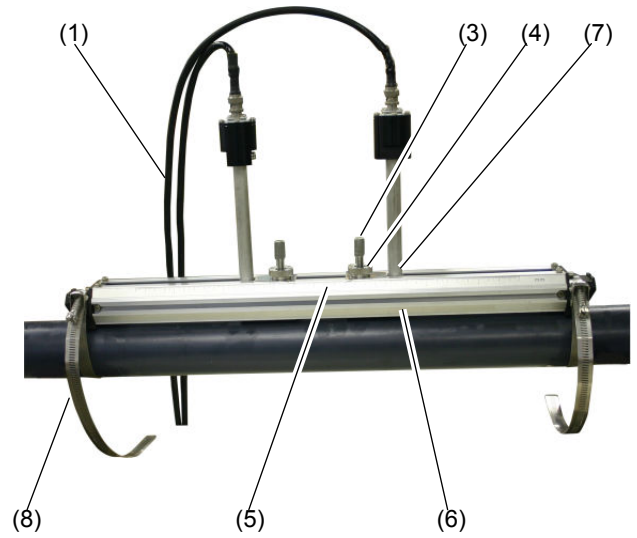

FSSH

No.	Name	Description
(1)	Signal cable	Transmits the send/receive signals.
(2)	Sensor unit	Sends and receives an ultrasonic wave.
(3)	Element holder	Attaches the sensor unit firmly to the pipe.
(4)	Lock nut	Fixes the sensor unit mounting position.
(5)	Scale	Reads the spacing between the sensor units.
(6)	Frame	Fastens the sensor unit on pipe.
(7)	High temperature detector	Sends and receives an ultrasonic wave.
(8)	Stainless steel belt	Fastens the sensor frame on pipe.

2. INSTALLATION

Select an installation location that satisfies the following conditions for ease of maintenance and inspection, service life of the instrument, and assurance of reliability all considered.



CAUTION

- (1) A place where ambient temperature and humidity are -20 to +60°C and 90% RH or less for detector (-20 to +60°C and 100% RH or less for detector (FSSE)).
- (2) A place not exposed to direct sunshine nor inclement weather.
- (3) Space for periodic inspection and wiring work is available.
- (4) A place not subjected to radiated heat from a heating furnace, etc.
- (5) A place not subjected to corrosive atmosphere.
- (6) A place not to be submerged.
- (7) A place free from excessive vibration, dust, dirt and moisture.

2.1. Detector mounting procedure

Mount the sensor on the pipe, and perform the following steps in order before making measurement.

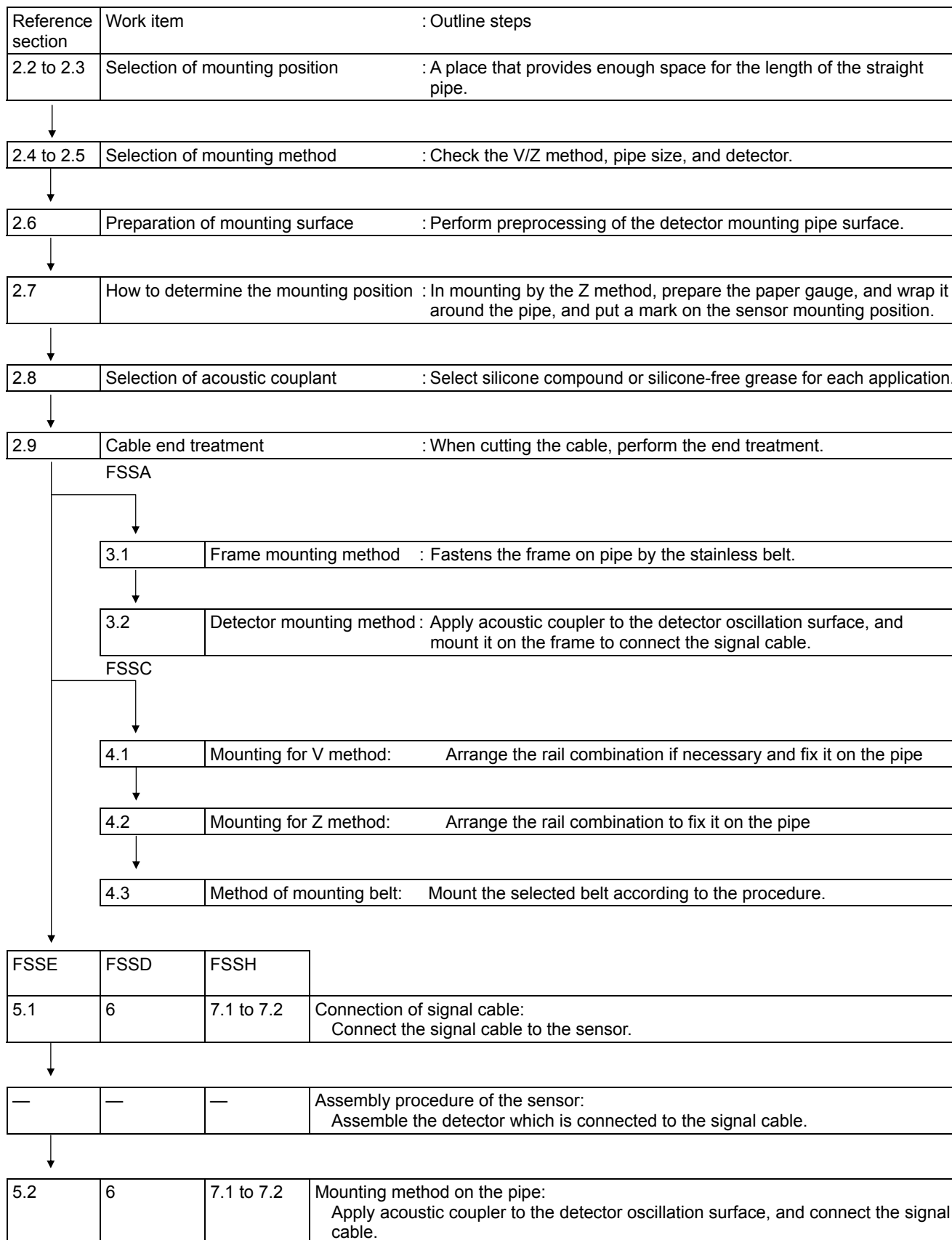

2.2. Selection of mounting position

Detector mounting location, i.e., the conditions of the pipe subjected to flow rate measurement exert a great influence on measurement accuracy. So select a location meeting the conditions listed below.

- (1) The place where secure the length of the straight pipe.
- (2) Elements (pump, valve, etc) on the upstream side must be greater than 30D away to prevent disturbances.
- (3) The piping must be filled with fluid free from air bubbles and foreign objects.
- (4) Make sure that a maintenance space is provided around the piping where the sensor is mounted. (See Fig. 2-1.)

Note) A space should be provided so that maintenance work can be made with workers standing on both sides of the piping.

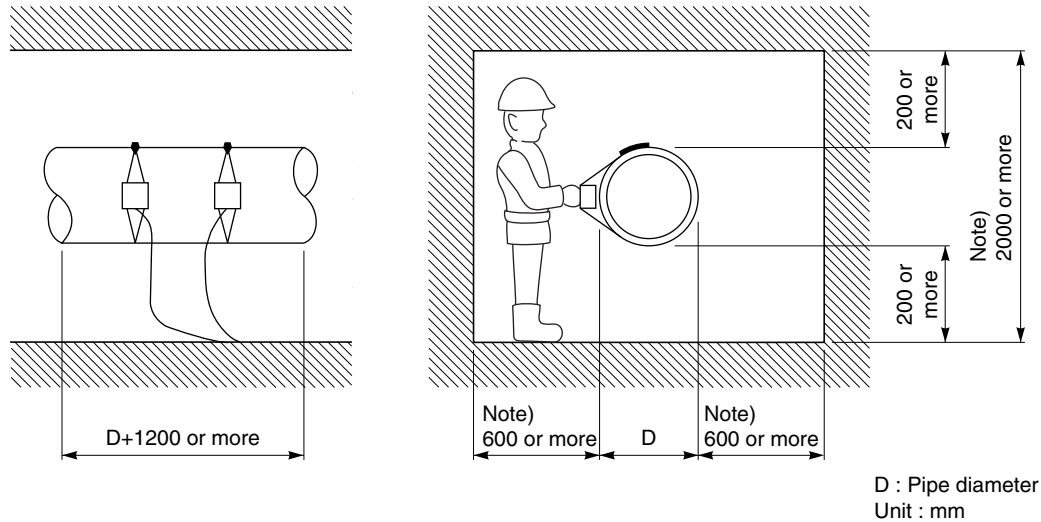
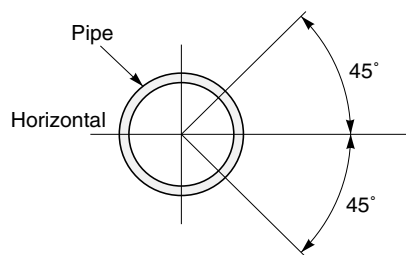

Fig. 2-1 Necessary space for the detector mounting position



- (1) Mount the detector within $\pm 45^\circ$ from the center plane in the case of horizontal pipe run.
For a vertical pipe, the detector can be mounted at any position on the outer circumference.



- (2) Avoid installing the sensor on a deformed portion of pipe or welded portion of pipe, or on flange.

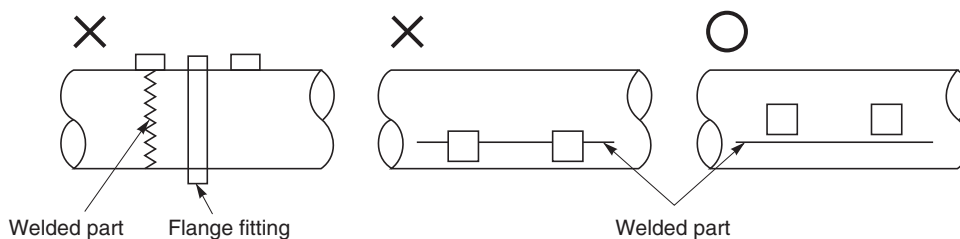

(3) The piping must completely be filled with fluid when it flows.

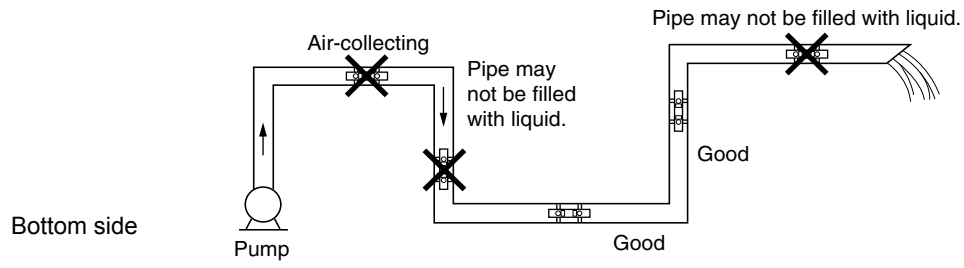

2.3. Length of straight pipe

The length of upstream and downstream straight pipe of the ultrasonic detector should be long enough to ensure accurate measurements.

(D is nominal diameter for a pipe)

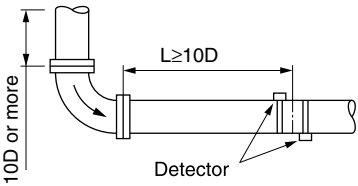
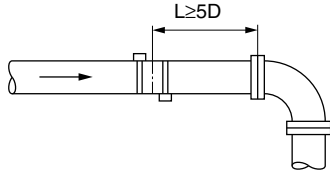
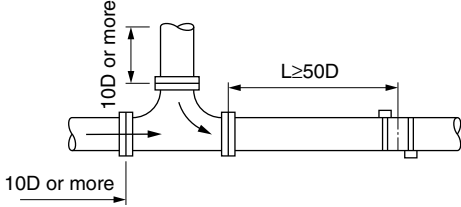
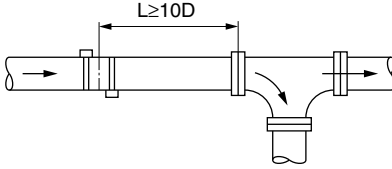
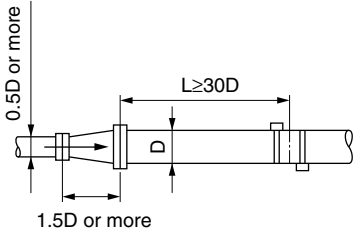
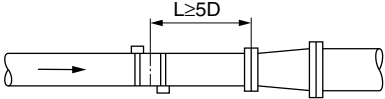
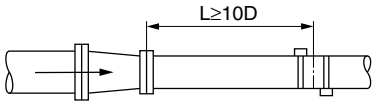
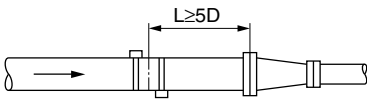
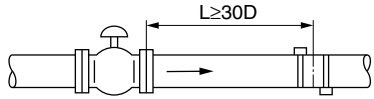
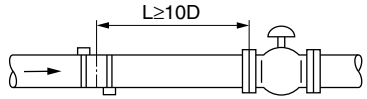
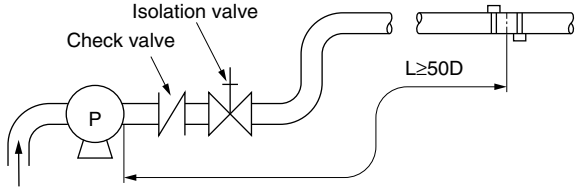
Type	Length of upstream straight pipe	Length of downstream straight pipe
90° vending		
Tee		
Extension pipe		
Contraction pipe		
Individual valves	 <p>When adjusting flow rate by the valve on the upstream side</p>	 <p>When adjusting flow rate by the valve on the downstream side</p>
Pump		

Note) Source: Japan Electric Measuring Instruments Manufacturers' Association (JEMIS-032)

2.4. Selection of mounting method

There are 2 methods for mounting the detector; V method and Z method. (See Fig. 2-2.)

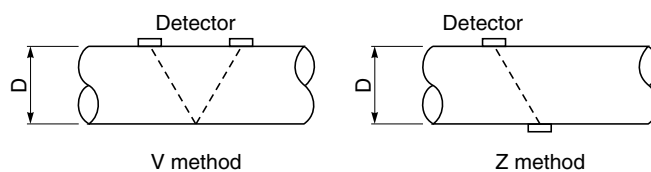

Fig. 2-2 Mounting method

The Z method should be used in the following cases.

- Where a V mounting space is not available.
- When measuring fluid of high turbidity such as sewage.
- When the pipe has a mortar lining.
- Piping is old and presumed to have a deposit of a thick layer of scales inside the piping.
- When measurement error occurs after mounting by V method.

Selection standard

For pipes with a diameter of 300 mm or larger, we recommend to use FSSE and mount it by Z method.

Type	Fluid temperature [°C]	Mounting method	Inner diameter of piping φ (mm)										
			13	25	50	100	200	250	300	400	600	1000	3000
FSSA	-20 to 100	V	25 [P, M] 225										
FSSC	-40 to 120	V	50 [P, M] 600 50 [Px] 300										
		Z	200 [P, M] 1200 200 [Px] 600										
FSSE	-40 to 80	V	200 [Px, P, M] 3000										
		Z	200 [Px, P, M] 6000										
FSSD	-40 to 100	V	13 [Px, P, M] 100										
FSSH	-40 to 200	V	50 [Px, P, M] 250										
		Z	150 [Px, P, M] 400										

Classification of piping materials {
 Px : PP, PVDF
 P : Plastic (PVC, etc.)
 M : Metallic piping (steel pipe, copper pipe, aluminum, etc.)

Note: If ultrasonic waves cannot pass through the piping because the piping material category is Px or the turbidity of the fluid is high, it is recommended to use FSSC, FSSE types.

2.5. Mounting of detector

For sensor spacing, select either method in advance.

- Calculate from flow transmitter

Please refer to the item of "Piping parameter setting method" in the instruction manual "Ultrasonic flowmeter transmitter" as separate volume

Display example: PROCESS SETTING S=16 (48mm)

Calculate from our website.

Address <http://www.fujielectric.com/products/instruments/products/flowmeter/top.html>

- Calculate from the CD attached to the equipment (flow transmitter)

2.5.1. Image figure of mounting dimension

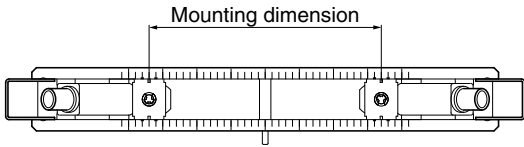
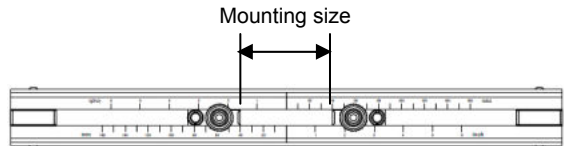
Type	FSSA	FSSC
Mounting method	V method	V meod
Mounting dimension		

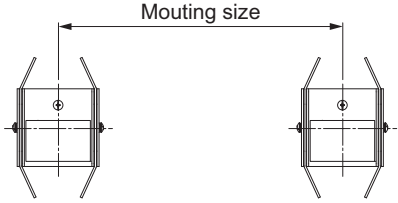
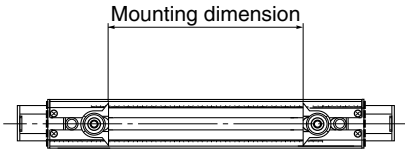
Type	FSSE	FSSD, FSSH
Mounting method	V method	V method
Mounting dimension		

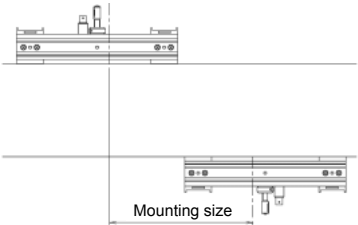
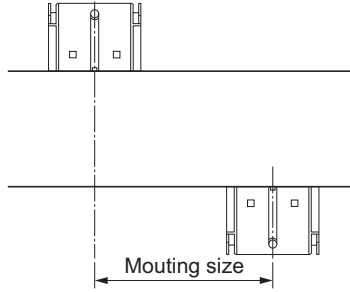
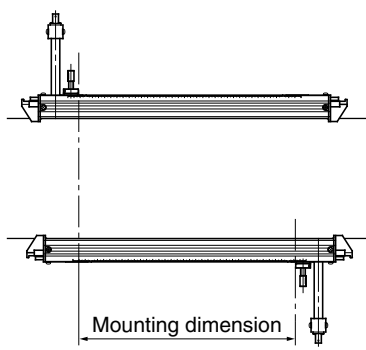
Type	FSSC	FSSE	FSSH
Mounting method	Z method	Z method	Z method
Mounting dimension			

2.6. Processing of mounting surface

Using thinner and sand-paper, remove the pitches, rust and uneven surface of the detector mounting piping over the entire mounting area of $(L) + 200\text{mm}$ wide. (Fig. 2-3)

Note) When the piping exterior is wrapped with jute, remove the jute and then perform the above treatment.

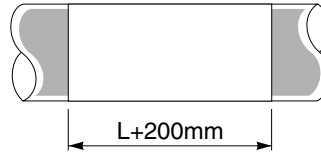
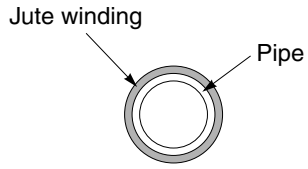

Length of frame

Type	L
FSSA	348mm
FSSC	480mm
FSSD	320mm
FSSH	530mm

Fig. 2-3

2.7. How to determine the mounting position

When the mounting is Z method, or Type FSSE, carry out the following to determine the mounting position beforehand. Gauge paper is necessary for this work. (Refer to "9.4. How to make gauge paper".)

- (1) Match the edge of gauge paper with the line at about 100mm from one end of the pipe portion treated for detector mounting, and wind the gauge paper so that the line marked on the paper is parallel with the pipe axis (fix with tape not to allow deviation). At this time, the edge of gauge paper should be aligned.

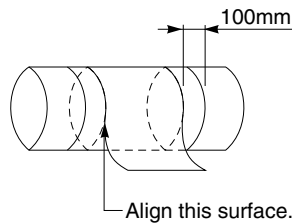

- (2) Extending the line marked on the gauge paper, mark straight line A on the pipe.

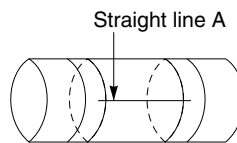

- (3) Mark a line along on edge of the gauge paper. Assume the intersection of the line and the straight line A is A_0 .

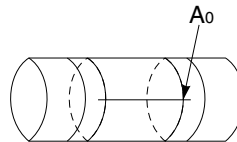

V method

Z method

Example) When $L = 200\text{mm}$

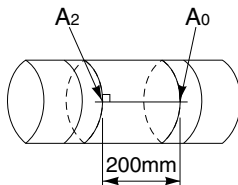

- (4) Remove the gauge paper and measure the mounting dimension from A_0 . Then, draw a line which crosses the straight line A (determine the position A_2).

A_0 and A_2 become the mounting positions.

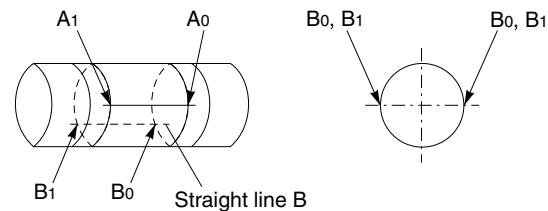

- (4) Measure the circumference of the pipe from the point A_0 , and mark a line (straight line B) between the point B_0 and B_1 obtained at $1/2$ of the circumference.

Example) When $L = 100\text{mm}$

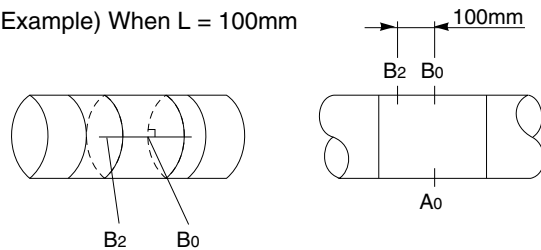

- (5) Mark the points B_0 and peel off the gauge paper. Measure the mounting dimension from B_0 to determine B_2 position. At this position, make a line orthogonal to the straight line B.

A_0 and B_2 become the mounting positions.

2.8. Selection of acoustic coupler

Acoustic coupler is a media that eliminates a gap between the detector and the pipe.

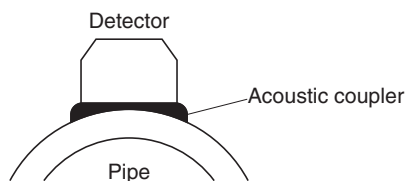

There are 4 types of acoustic coupler. Select a suitable one referring to the following table.

Type	Silicone compound (KE-348W)	Silicone-free grease (HIGH Z)	Silicone grease (G40M)	High temperature grease (KS62M)
Fluid temperature	-40 to +150°C	0 to +60°C	-30 to +150°C	-30 to +250°C
Teflon tube	×	○	○	○

Note1) Before coating the acoustic coupler, eliminate material such as rust, water drops, dust, oil/ grease or other foreign matters from the pipe surface using the thinner, sand paper, etc.

Note2) Curing time of silicone rubber (KE-348W)

Thickness	20°C, 60%RH
1mm	12h
2mm	24h
3mm	48h

- If the environmental temperature and humidity rise, the curing time of silicone rubber becomes shorter.
- Curing time of surface is between 1 to 60 minutes.
- It takes about three days to obtain sufficient adhesive strength.

2.9. Signal cable end treatment



When cutting the coaxial cable, make sure that the upstream side and the downstream side are the same in length. Different cable length results in output error or abnormal output.

2.9.1. Signal cable end treatment for type FLYA (For FLR-3)

The end of coaxial cable is treated at the factory prior to delivery. If the cable needs to be cut before use, the conductor and the shielding wires should be treated using clamp terminals.

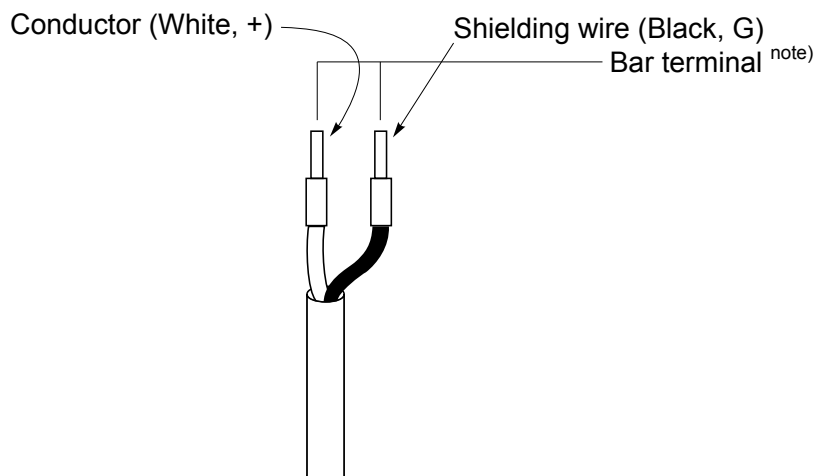

2.9.2. Signal Cable end treatment for type FLYD (For FSV-2)

The end of coaxial cable is treated at the factory prior to delivery. If the cable needs to be cut before use, the conductor, the shielding wires, and the external shielding wire should be treated using bar terminals.

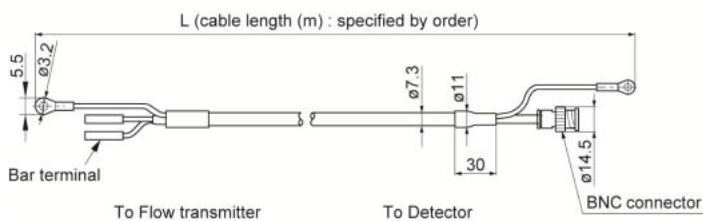

Kind of clamp terminal

Name	Flow transmitter side (for M3 screw)	Detector side
External shielding wire (green)	R1.25-3	BNC Connector
Conductor (White, +)	Bar terminal <small>note</small>	
Shielding wire (Black, G)	Bar terminal <small>note</small>	

Wire size (mm ²)	AWG	φD1 (mm)	φD2 (mm)	Type
0.5	20	1	2.6	H0.5/16
0.75	18	1.2	2.8	H0.75/16
1	17	1.4	3	H1/16
1.5	16	1.7	3.5	H1.5/16

Recommended bar terminal

* • Weidmuller

www.weidmuller.com

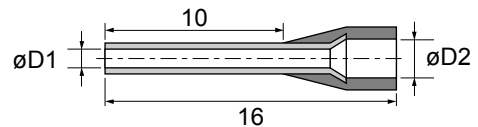

Note1) Make sure to use PZ6/5 (H0.25 to H6 for sleeve) as a crimp tool for caulking.

Note2) Applicable sleeve is required for electric wire.

Note3) Insert the electric wire to the end of H sleeve so as to crimp.

Note4) Length of stripped wire is 12mm.

3. MOUNTING OF FSSA TYPE

3.1. Frame mounting method



CAUTION

Be careful not to cut your hand with the stainless steel belt when mounting the frame.

- (1) Pass the stainless steel belt through 2 belt holes on the frame as shown in Fig. 3-1.



Fig. 3-1

- (2) As shown in Fig. 3-2, apply the frame on the pipe section subjected to a surface treatment.



Fig. 3-2

- (3) Turn the stainless steel belt around the pipe as shown in Fig. 3-3, and insert the lever.



Fig. 3-3

- (4) Adjust the frame so as to be in parallel with the pipe, and check whether the frame is securely tightened while pulling down the lever. Adjust the frame at the bending position A.

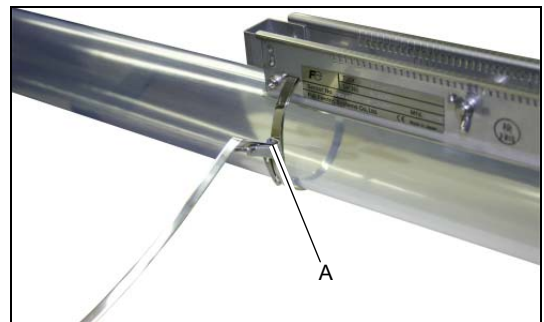

Fig. 3-4

- (5) When the stainless steel belt is long, cut it as shown in Fig. 3-5.



Fig. 3-5

- (6) Fit the lever window securely on the dowel. When the frame is not securely tightened, move the lever upward using blade-edge screwdriver, etc, and readjust the frame at the bending position in (4).



Fig. 3-6

Note) The stainless steel belt can be used repeatedly.

3.2. Mounting of sensor unit

- (1) Mount both sensor units spaced at the SPACING value [$S = _ _$] (number of graduations on frame) indicated after setting the piping parameters.

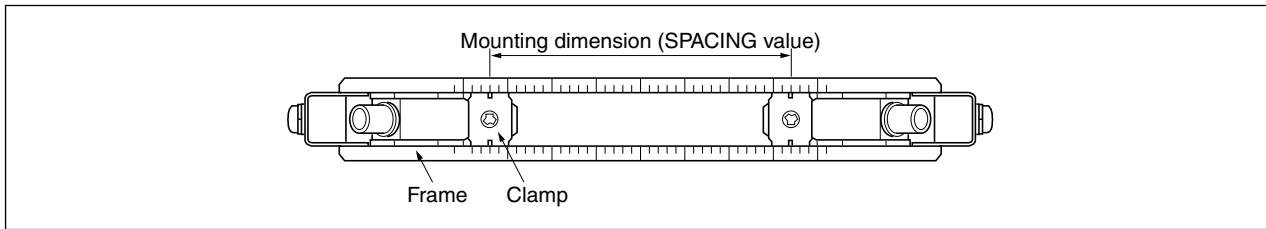

Fig. 3-7

- (2) Before mounting the sensor unit into the frame, sufficiently apply acoustic coupler (or silicone-free grease*) over the entire transmission surface of the sensor unit, taking care not to introduce bubbles. (Fig. 3-8)

*) When using silicone-free grease, pay attention to the fluid temperature range. The fluid temperature range is shown below.

- Silicone compound : -40 to +150°C
- Silicone-free grease : 0 to +60°C

When using silicone-free grease, reapply it on the transmission surface of the sensor unit approximately once every 6 months. (Silicone rubber need not be reapplied.)



Fig. 3-8

- (3) Then insert the sensor unit into the frame, align the slit provided on the pressing fixture of the sensor unit with graduations located on the frame top surface (see Fig. 3-9), and press the sensor unit until the fixture claws are engaged with the frame side square holes. Mount both sensor units so as to be roughly symmetrical with respect to the frame. (Refer to Fig. 3-10)

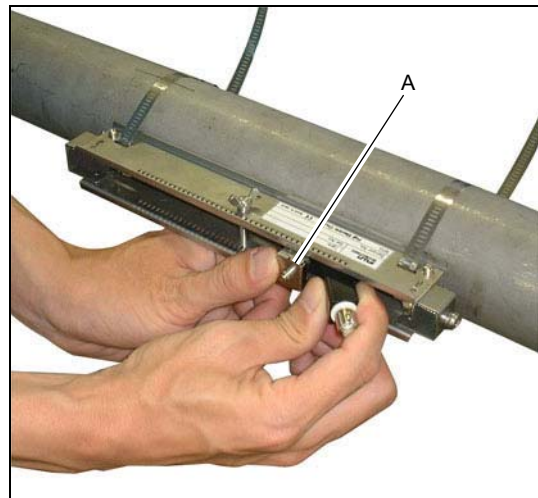
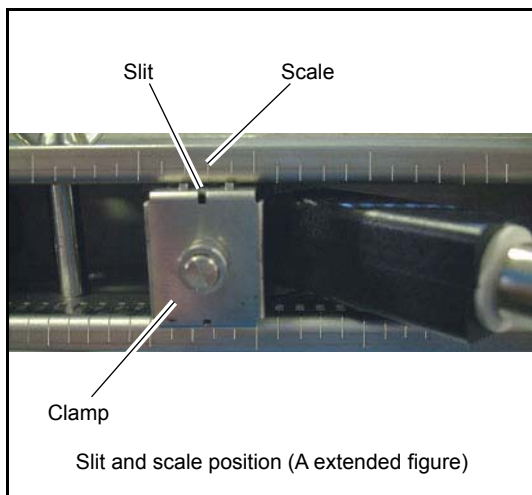

Fig. 3-9

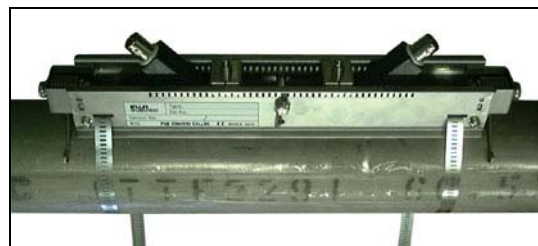

Fig. 3-10



CAUTION

Mount the sensor units so that their BNC connectors will face outward (Fig. 3-11a). If at least one is mounted opposite, the measurement is impossible (Fig. 3-11b, c). The pressing fixture claws must completely be engaged with square holes provided on sides of the frame. Otherwise, the sensor and pipe will not correctly get in contact with each other, whereby the measurement will be impossible.

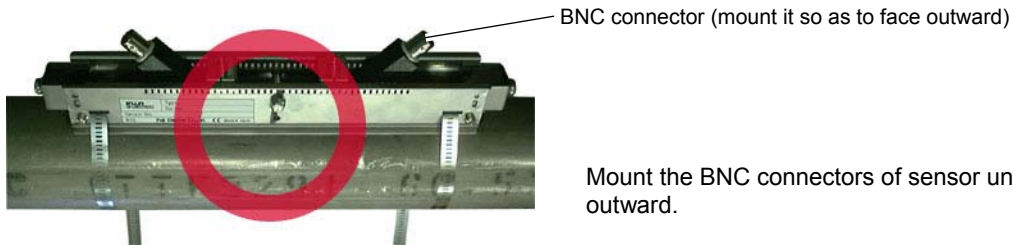
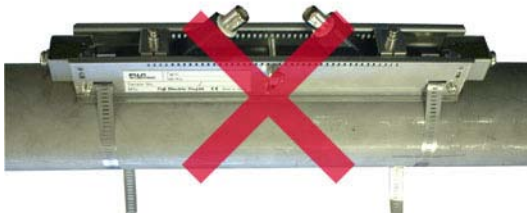

Fig. 3-11a



Do not mount the BNC connectors of sensor units in the same direction.

Fig. 3-11b



Do not mount the BNC connectors of sensor units so as to face inward.

Fig. 3-11c

Fig. 3-11

- (4) Engage the signal line with BNC connectors of the sensor units. At this time, do not mistake the upstream and downstream sides for each other. Engage the red BNC connector upstream, and the black BNC connector downstream (see Fig. 3-12).

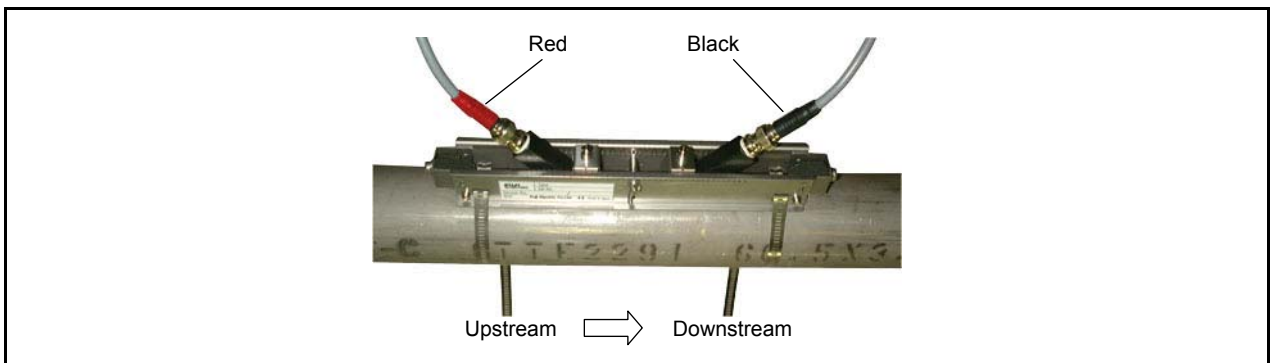

Fig. 3-12

4. MOUNTING OF FSSC TYPE

4.1. Mounting for V method

CAUTION

When adjusting the length of the rail, make sure to work on the table.
Injury or damage of the products may be caused by falling.
Please pay attention not to loose screws.

- (1) Confirm the Item 2.5. (mounting dimension of the sensor) whether or not you have to extend the rail.
 - Mounting pitch $\leq 300\text{mm}$. . . Mounting pitch is adjustable without extending the rail.
 - Mounting pitch $> 300\text{mm}$. . . First, rail is require to be extended.
- (2) How to extend the rail
 - Loosen the two fixing screws (M4) on the end of extension rail (blue). (turning screw two times)

Note: Do not turn the screw (M4、L=6mm) excessively .Otherwise loose screw may come off and become lost.



- Slide the guide rail (silver). Fix the rail length with fixing screw which is adjustable in every 10mm.



- When extending the rail 300mm or more, slide the opposite side of the rail as well (Max.400mm extendable).

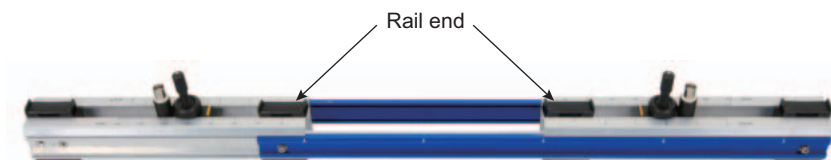

Note) In case the rail is extended 200mm or more, middle of the rail will become unstable. Thus make sure to mount the supplied rail end and fix the four part of the rail with fixing belts to use.

For easy use and maintenance

Even if extending rail is not required, extend the rail 100mm (=3.937inch) at least if mounting dimension is 100mm or more, which enable to remove the sensor unit in the middle of the rail without removing the rail from the pipe.

Additionally, There is a merit that it makes regular maintenance easy only if grease is used as acoustic coupler. Please conduct it in the same way when removing the sensor with water-proof treatment from the rail.

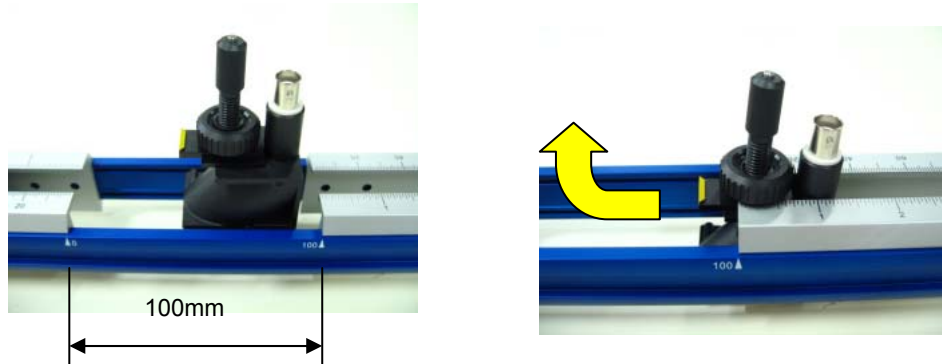

- (3) Loosen the lock nut and adjust the mounting dimension of the sensor unit

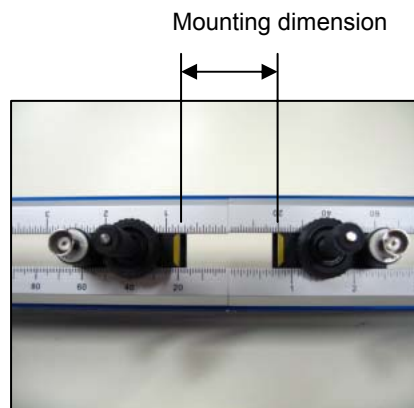

- (4) Apply the acoustic coupler on the transmission surface of the sensor unit.
For easy applying, Turn the element holder and remove the sensor unit before applying.
Return the sensor unit where it was after applying.

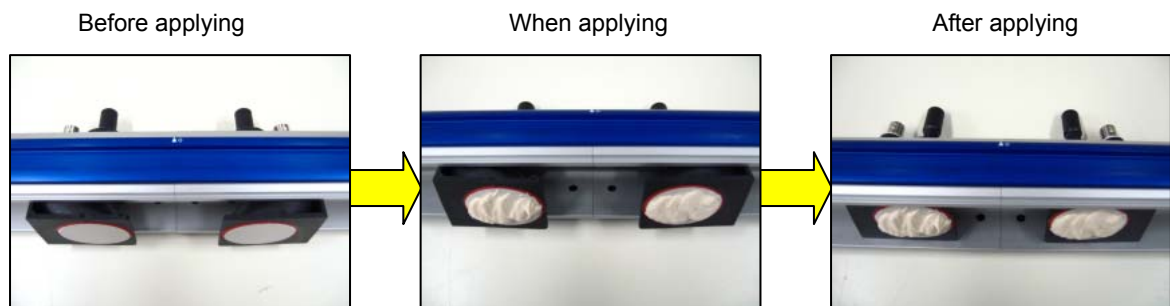

- (5) Fix the rail with the mounting belt on the pipe to be measured and turn the element holder to attach the transmission surface of the sensor unit on the pipe correctly.

Note) Please pay attention to the contacting part as not to attach the rail on the pipe excessively since excessive pressure causes the rail end to come off the pipe depending on size and type of belt, or causes the resin pipe to deform and causes measurement error to occur.

Please refer to the item "4.3 Method of mounting belt" which vary depending on the belt type.

Mounting on the pipe

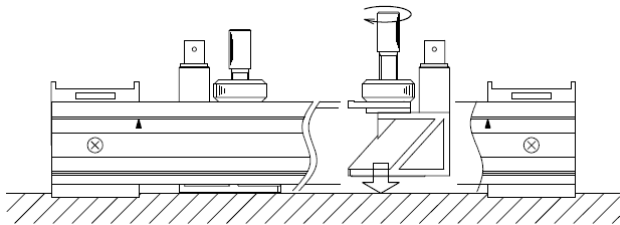

Example: Excessive turning element holder causes the rail end to come off the pipe.

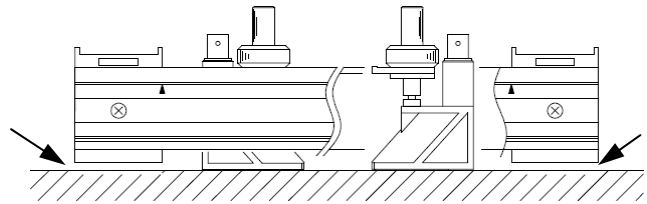

Example: Excessive turning element holder cause the resin pipe to deform

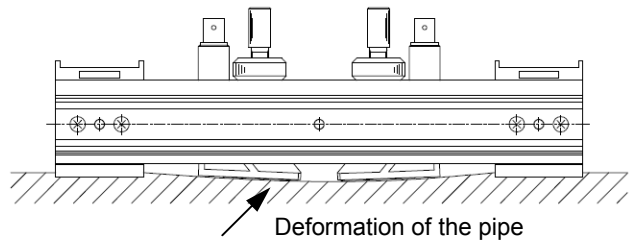

- (6) Connect the signal cable. Note) Please make sure that power of transmitter is turned OFF when connecting. Connection example: discriminate the cable color between the upper stream "Red" and downstream "Black" and connect them to transmitter with matching color cable. For type of water-proof treatment, signal cable is already connected as factory default.

Without water-pooof treatment

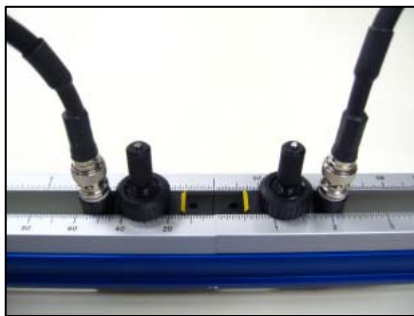

With water-proof treatment



- (7) If there is not much space to mount since pipe size is small and short length, one of guide rail can be removed and use the rail as a half size as shown below.
However, it is available to use only if dimension of mounting pitch is 65mm or less.

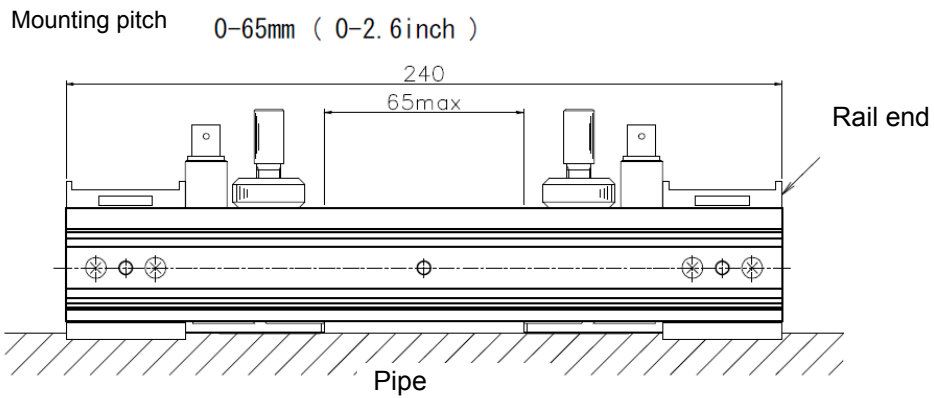

4.2. Mounting for Z method

- (1) Confirm the mounting dimension in Item 2.5
- (2) Mark the mounting position on the pipe.
Please refer to Item 2.7 "How to determine the mounting position"
- (3) Preparation of the rail
 - Set up the rail for Z method
 - 1) Loosen the 4 screws which fix the extension rail (blue) and remove the guide rail.
 - 2) Screw the each supplied rail end with 4 screws. (2pieces)

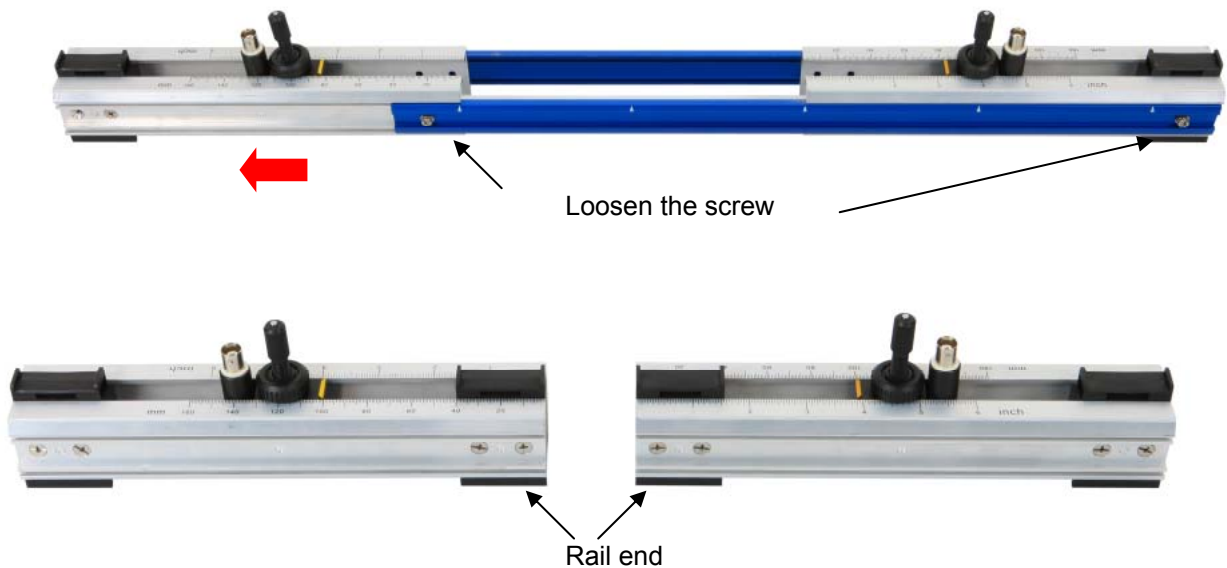

- (4) 4.1. Apply the acoustic coupler on the sensor unit as same as Item4)

(5) Fix the rail of sensor unit with mounting belt on the marked line and turn the element holder to attach the surface of the sensor unit to the pipe.

Note) Note that excessive pressure may cause the rail end to come off the pipe.

Mounting method vary depending on the type of belt. Please refer to the Item.4.3 for details.



(6) Connect the signal cable.

Note) Please make sure that power of transmitter is turned OFF when connecting.

Connection example: discriminate the cable color between the upper stream "Red" and downstream "Black" and connect them to transmitter with matching color cable.

For type of water-proof treatment, signal cable is already connected as factory default.

In case you bend the base of the signal cable with water-proof, length of minimum radius to bend is 100mm.

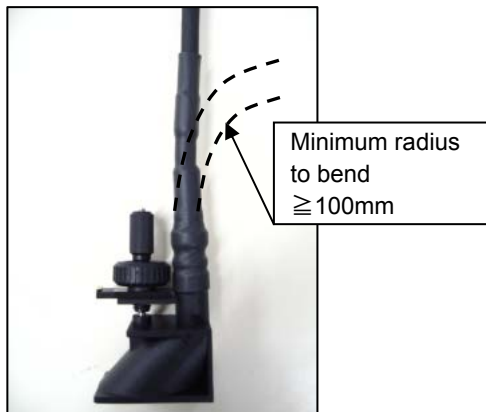
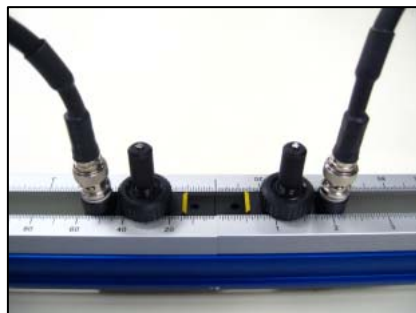

4.3. Method of mounting belt



CAUTION

Please use the gloves and the pliers when conducting work on stainless steel belt.
Otherwise, you may hurt yourself.

Followings are description how to use the belt selected at 6th digit of code of symbols.
It is described based on FSSC type and it is also reference for other types

(1) Stainless steel belt (6th digit: A)

1-1) Put the belt through the hole of the rail end and wrap it around the pipe.



1-2) Put the belt through the latch.

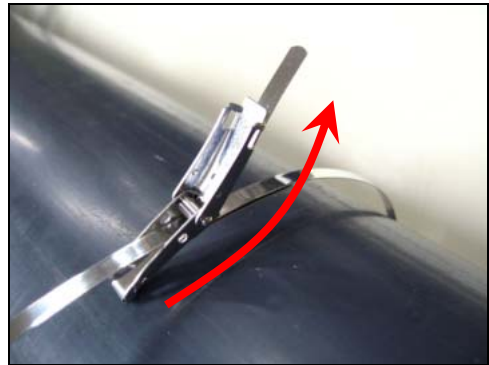

1-3) Return the belt at the end of the latch



1-4) Put the latch back on.

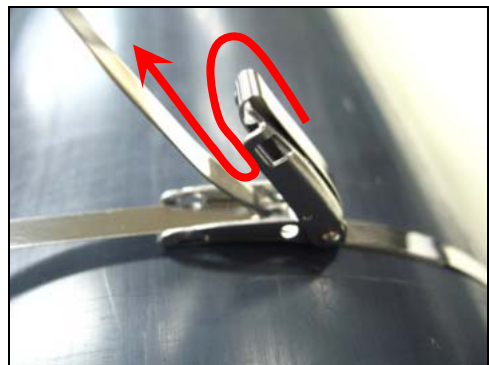

1-5) Lock the latch.

Please make sure the tension of the belt to put the latch back on.
When tension is not tight enough, go back to the procedure 1-3) and make an adjustment.
After locking the latch, make sure to cut the extra length of the belt or wrap it around the pipe.



- (2) Velcro band (6th digit: B)
 2-1) Wrap the belt with rough side facing up around pipe.



- 2-2) Put it through the buckle.



- 2-3) Fix the belt with pulling back



- (3) Belt with SUS screw clamp (6th digit: C)
 3-1) Put the belt through the hole of the rail end and wrap it around the pipe.



- 3-2) Put the belt through the fixing clamp.



- 3-3) Pull the belt, lay down the screw and wrap it tighten the screw with screwdriver around the pipe.



- 3-4) Make sure the tension of the belt and make an adjustment.



(4) Wire (6th digit: D,E)

【For mounting of V method】

4-1) Adjust the wire length to the pipe size



4-2) Put the wire through the hole of rail end and wrap it around the pipe and hook it with mounting spring to fix.
Mounting spring length is approx. 180mm.

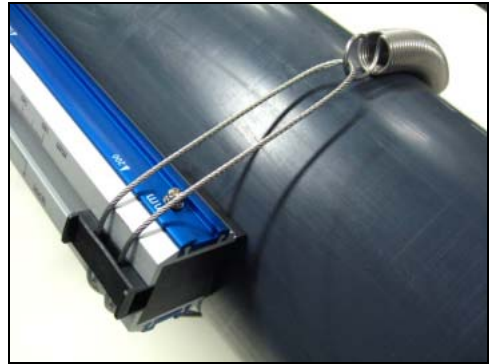

【For mounting of Z method】

4-1) Adjust the wire length to the pipe size



4-2) Put the wire through the hole of rail end and wrap it around the pipe and hook it with mounting spring to fix.
Mounting spring length is approx. 180mm.



5. MOUNTING OF FSSE TYPE

5.1. Connection of sensor cable



CAUTION

When engaging or disengaging the cover, be sure to wear protective gloves. Otherwise, you may cut a hand.

- (1) Remove the M4 screws on the detector cover.
Remove the cover while opening it.



- (2) Confirm the mounting position on the pipe.
● Align the transmitting direction marks so that they are facing with each other.

Transmitting direction marks [INSIDE]

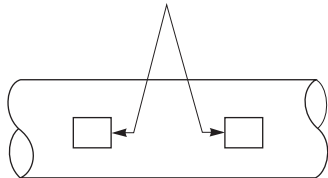

- (3) Remove the two M4 screws to remove the cable clamp.
Put the cable and fix the conversion cord with the cable clamp (one side only).
Note: Connect the conversion cord to the terminal (black to G terminal, white to + terminal).
Note: Connect to the M4 crimp terminal side (Appropriate tightening torque: 80 to 120 [N·cm])

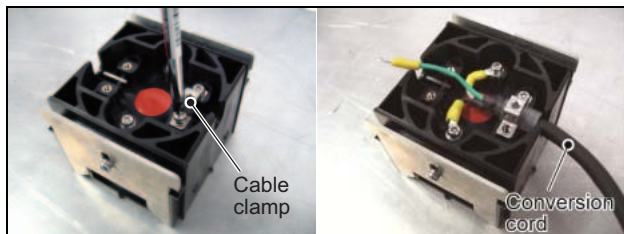

- (4) Remove foreign matters from the terminals, and mold them while terminal block with silicone filler.
● Cut off the tip of the silicone filler tube. Apply silicone to the terminal block while pressing the head of the tube against the bottom of terminals.
At this time, care should be taken to prevent entry of air bubbles.
Put the cover on the sensor.

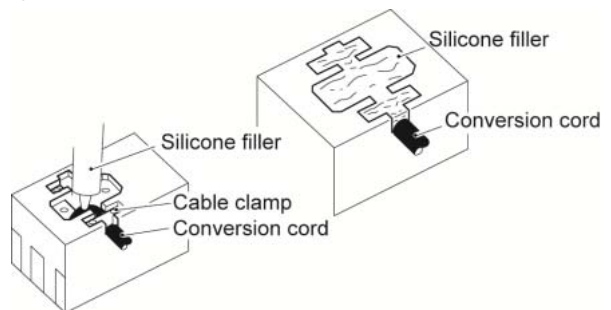

- (5) Connect the signal cable and conversion cord with BNC connector.
Water-proof grade of connector part is IP66 under the condition of interdigitation.
Please avoid using this in the water.

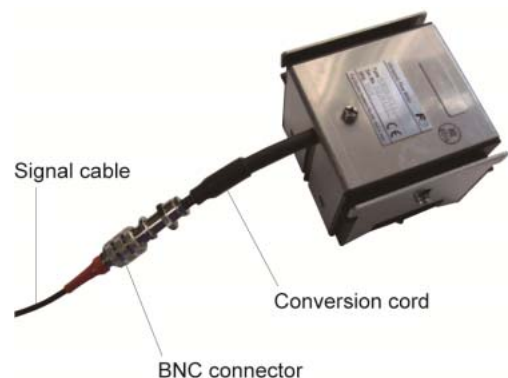

5.2. Mounting method on the pipe

- (1) Adjustment of guide plate height
Place the sensor on the pipe surface in parallel with the pipe axis.

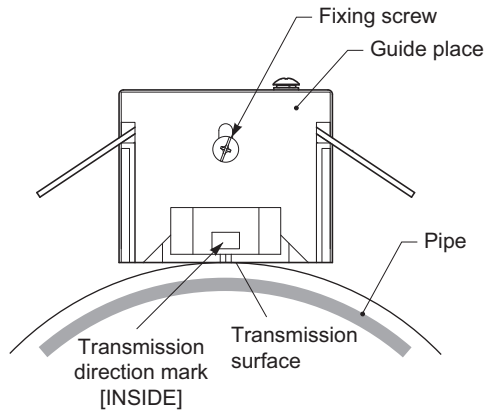

Loosen the guide plate fixing screw and slide the guide plate until its edge and transmitting surface touch the surface of pipe.
Tighten the retaining screw.

- (2) Setting of wire rope length
Place the sensor on the marked lines and fit the wire rope and fastening spring.

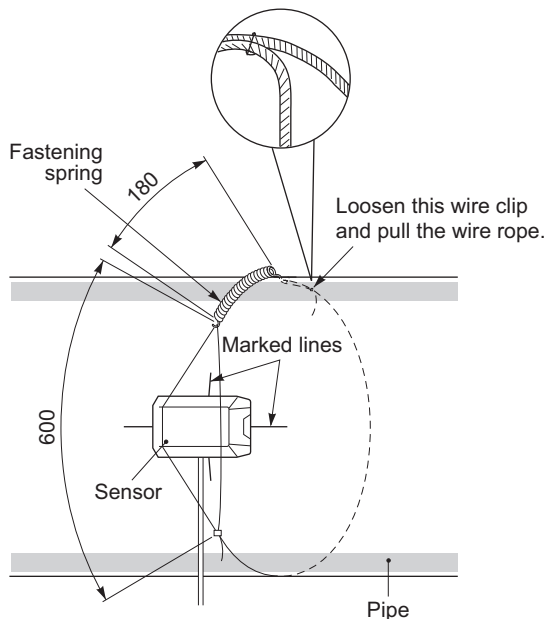

Loosen the wire clip and pull the wire rope until the overall length of fastening spring approximates 180mm. Then tighten the wire clip. (The fastening spring has a free length of 110mm.)
Remove the sensor with the wire rope fixed in place.

- (3) Mounting of sensor
- Clean the sensor transmitting surface and pipe mounting surface.
 - Spread acoustic coupler over the whole transmitting surface of the sensor.
 - The thickness of acoustic coupler should be about 3mm.



- Spread the wire rope near the marked lines in the left-right direction, bring the sensor in close contact and fit the wire rope.



- Make sure that the matching mark on the sensor is aligned with the marking line. In addition, make the transmitting direction marks of sensors face each other.



- Make sure the matching mark of sensor is aligned with the marked line and connect the signal cable to the flow transmitter.

Note: Do not pull the signal cable. Otherwise, the sensor will be activated to disturb measurement.

6. MOUNTING OF FSSD TYPE

- (1) Loosen the lock nut and slide the sensor so as to meet the mounting dimension (the first decimal place at the displayed mounting dimension is rounded) and then tighten the nut.

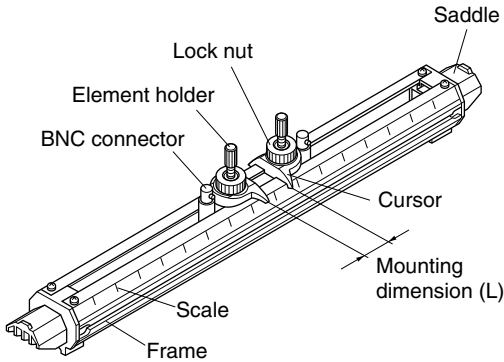

- (3) Mount the sensor saddles on the pipe with stainless belt. Wrap the stainless belt around the pipe previously for easy mounting.

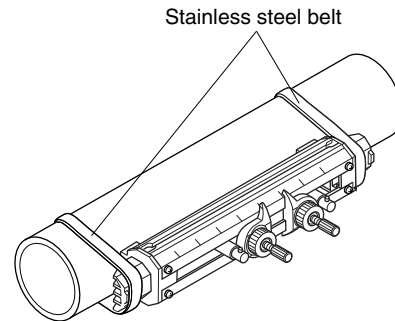

- (2) Apply the acoustic coupler on the transmitting surface of sensor while spreading it evenly.

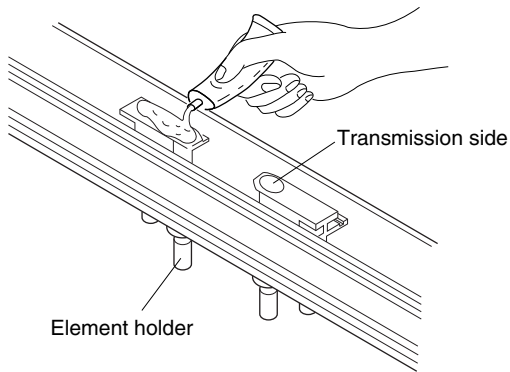

- (4) Make sure that the sensor is mounted in parallel with the piping and that the mounting position is correct. Then, turn the element holder clockwise until the sensor is firmly fitted to the piping.

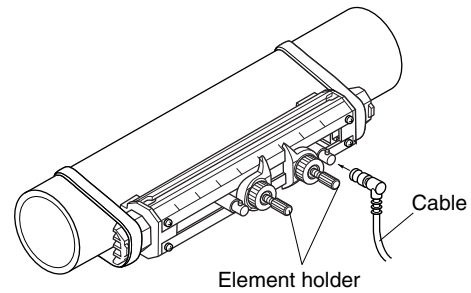

Turn the element holder counterclockwise to return the sensor.
Clean the surface of the pipe and mount the sensor on the pipe.

Stop turning the element holder where the transmitting surface contacts the surface of pipe, and thus the element holder will not rotate. Do not turn it excessively.

7. MOUNTING OF FSSH TYPE

Detector for high temperature is mounted on pipe with a diameter of $\Phi 50$ to 250 (V method) or $\Phi 150$ to 400 (Z method) for measurements.

7.1. Mounting of detector (in case of V method)

Mounting the detector using the following procedure.



CAUTION

Do not perform mounting when the temperature of pipe is high. Otherwise, you may suffer a burn.

- (1) By loosening lock nuts, slide the sensor to fit the mounting size displayed on the converter. Tighten the lock nuts.

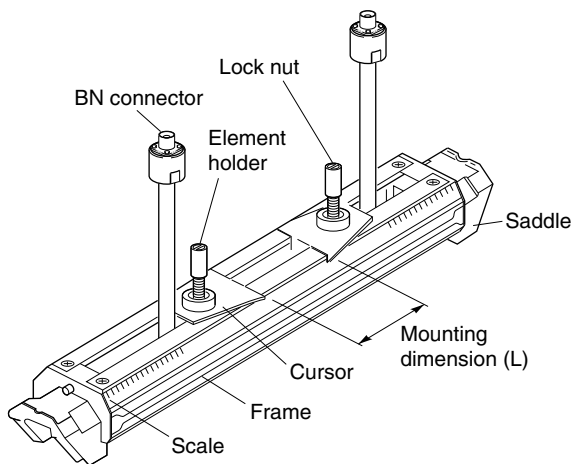

- (3) Mount the sensor saddles on the pipe with stainless steel belt.

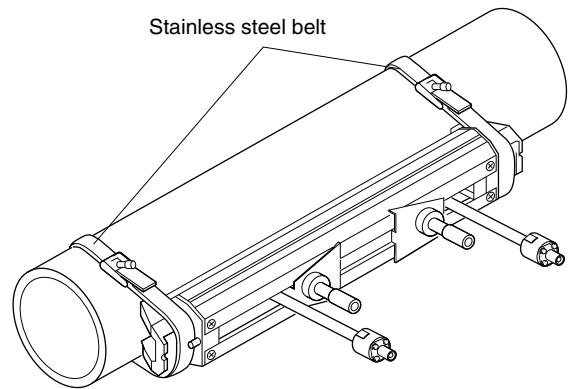

- (2) Spread acoustic coupler over the whole transmitting surface of the sensor.

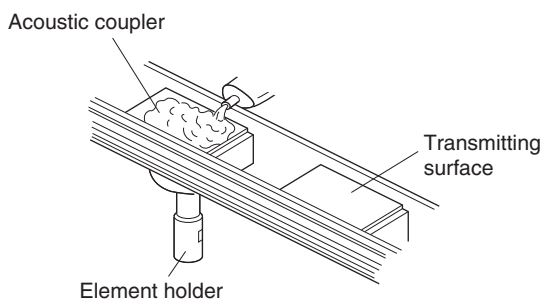

- (4) Make sure that the sensor is mounted in parallel with the piping and that the mounting position is correct. Then, turn the element holder clockwise until the sensor is firmly fitted to the piping.

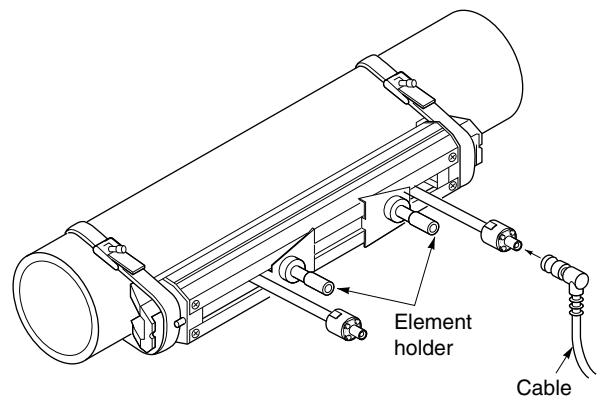

Turn the element holder counterclockwise to return the sensor.
Clean the surface of the pipe and mount the sensor on the pipe.

Stop turning the element holder where the transmitting surface contacts the surface of pipe, and thus the element holder will not rotate. Do not turn it excessively.

7.2. Mounting of detector (in case of Z method)

Mounting the detector using the following procedure.

- (1) Remove saddle set screws at 4 locations, and remove a saddle and a sensor unit out of the frame. Also, remove a saddle on the guide rail for high temperature sensor (option).

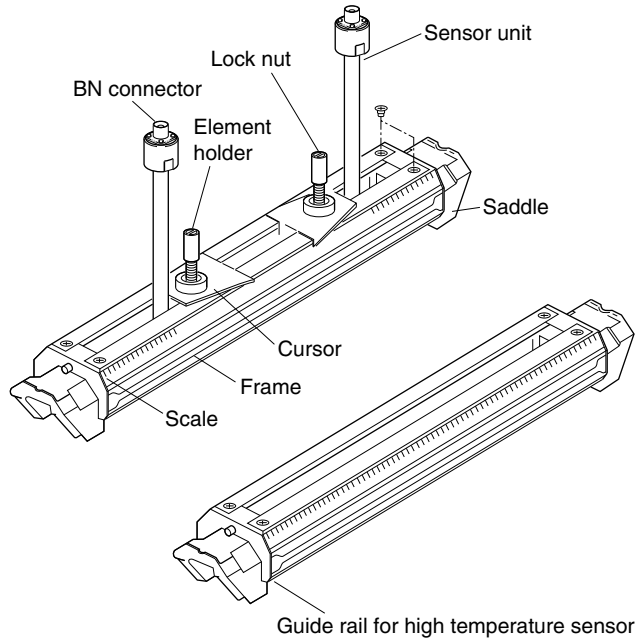

- (2) Mount the removed sensor unit on the guide rail for high temperature sensor. Fasten the sensor unit with mounting dimension (L).

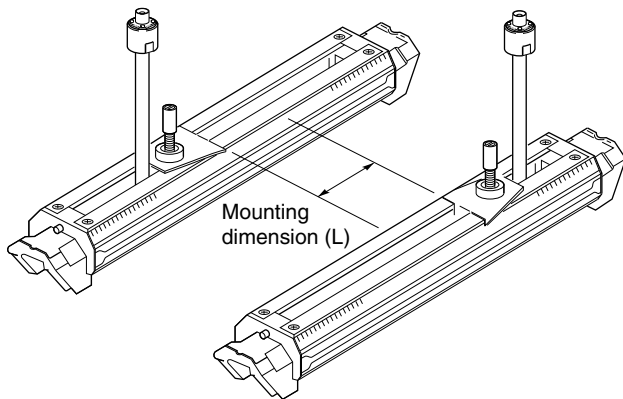

- (3) Spread acoustic coupler over the whole transmitting surface of the sensor.

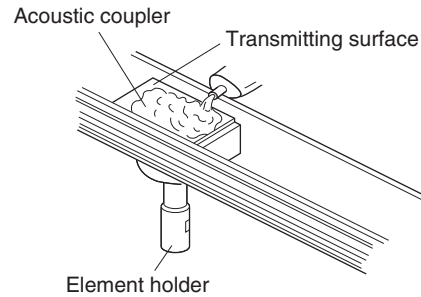

Turn the element holder counterclockwise to return the sensor. After cleaning the surface of the pipe, the sensor should be mounted.

- (4) Mount each sensor individually on the marking line.

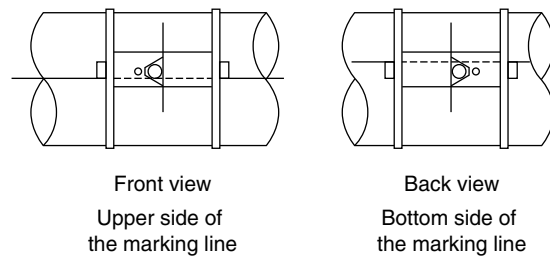

- (5) Make sure that the sensor is mounted in parallel with the piping and that the mounting position is correct. Then, turn the element holder clockwise until the sensor is firmly fitted to the piping. Stop turning the element holder where the transmitting surface contacts the surface of pipe, and thus the element holder will not rotate. Do not turn it excessively.

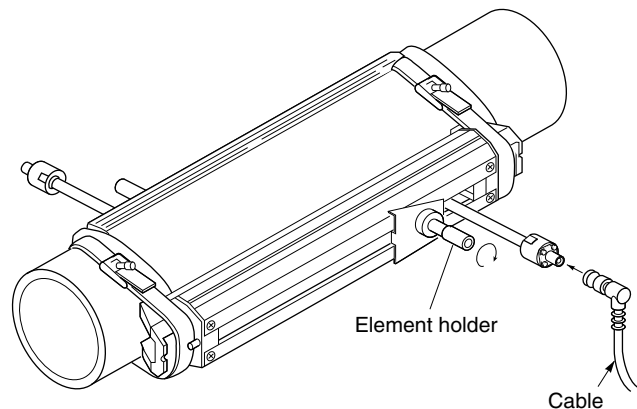

8. CHECK AND MAINTENANCE

8.1. Daily Check

Visually check the following items.

- Whether screws are loose. ⇒ Tighten.
- Whether BNC connector come off. ⇒ Reconnect.
- Whether detector mounting band is loose. ⇒ Stretch.
- Whether received wave is abnormal (LED lit red). ⇒ Check whether piping is filled or not. Remove bubbles or foreign matters, if mixed in measurement pipe. Also check if detector mounting and wiring are set up properly.

- Whether signal cable is break ⇒ Conduct the continuity test on both side of the cable by tester.
- Whether signal cable maintains the insulation. ⇒ Check the insulation resistance value between the signal cables. Performance of insulation resistance : 500V DC, 100Ω or more

8.2. Periodic Inspection

8.2.1. Checking zero point

Stop the fluid flow, fill the measurement pipe fully, and check the zero point.

8.2.2. Reapplying grease

When using grease for the acoustic couplant, reapply it on the transmission surface of the sensor unit approximately once every 6 months.

Note) Silicone rubber need not be reapplied.

Note) When removing the sensor attached with silicone rubber, do not pull it off forcedly.
Remove the rail and others first and then turn the sensor itself to remove.

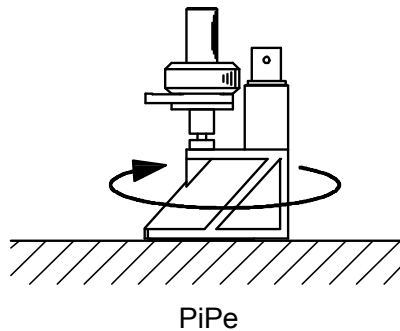

9. APPENDIX

9.1. Specifications

Please refer to the item 9.3 for the specification of the special detector (for small diameter pipe, large diameter pipe and high temperature)

Operational specifications

System configuration:

Single-path system of a flow transmitter (Type FSV or FLR) and a detector (Type FSS)

Applicable fluid:

Homogenous liquid where the ultrasonic signal can be transmitted
 Bubble quantity: 0 to 12vol% (for pipe size 50A, water, velocity 1m/s)
 Fluid turbidity: 10000mg/L max.
 Type of flow: Fully-developed turbulent or laminar flow in a full-filled pipe

Flow velocity range:

Type FSV: 0 to $\pm 0.3 \dots \pm 32$ m/s
 Type FLR: 0 to $\pm 0.3 \dots \pm 10$ m/s

Signal cable:

Coaxial cable max.60m for detector (Type: FSSA), max.150m for others.
 Heat resistance: 80°C

Installation environment:

Non-explosive area without direct sunlight, corrosive gas and heat radiation.

Ambient temperature:

Detector: -20 to +60°C

Ambient humidity:

90%RH max.

Grounding:

Class D (100 Ω or less)

Applicable piping and fluid temperature:

Detector	Pipe size (Inner diameter) ϕ mm	Applicable pipe material (Note1)	How to mount	Flued temperature range (°C) (Note2, 3)
FSSA	25 to 50	Plastic (PVC, Others)	V method	-20 to +100
	50 to 225	Plastic (PVC, Others)		
FSSC	50 to 600	Metal pipe (Stainless steel, Carbon steel, Copper, Aluminum, Others)	V method	-40 to +120
	600 to 1200		Z method	

Note1) Please select the FSSC type if following condition.

- When pipe material is PP or PVDF, limit of pipe wall thickness is 15mm or more for PP, 9mm or more for PVDF
- When pipe material is hard to penetrate the ultrasonic wave such as cast-iron pipe, lining pipe and old carbon steel pipe etc.,
- Lining material is tar epoxy, mortar and rubber etc..
- In case lining is removed from the pipe, Measurement can not be conducted

Note2) When silicon grease is used as acoustic coupler, Fluid temperature limit is 0 to 60°C no matter what detector is selected.

Note3) Heat-resistant shock temperature: for 30 minutes at 150°C

Note4) For pipes with a diameter of 300 mm or larger, we recommend to use FSSE and mount it by Z method.

Performance specifications

Rated accuracy:

<for flow transmitter FSV-2>

Detector Type	Pipe size (diameter) mm	Flow velocity (m/s)	Accuracy	
			Plastic pipe	Metal pipe
FSSA	$\phi 25$ to $\phi 50$	2 to 32	$\pm 2.0\%$ of rate	—
		0 to 2	± 0.04 m/s	—
	$\phi 50$ to $\phi 225$	2 to 32	$\pm 1.0\%$ of rate	$\pm 2.0\%$ of rate
		0 to 2	± 0.02 m/s	± 0.04 m/s
FSSC	$\phi 50$ to $\phi 200$	2 to 32	$\pm 1.5\%$ of rate	
		0 to 2	± 0.03 m/s	
	$\phi 200$ to $\phi 1200$	2 to 32	$\pm 1.0\%$ of rate	
		0 to 2	± 0.02 m/s	

<for flow transmitter FLR-3>

Plastic pipe

Detector Type	Internal diameter	Velocity: 2m/s or higher	Velocity: Less than 2m/s
FSSA	$\phi 25$ to $\phi 50$ mm	$\pm 2.5\%$ of rating	± 0.05 m/s
FSSA, C	$\phi 50$ to $\phi 1200$ mm	$\pm 1.5\%$ of rating	± 0.03 m/s

Metal pipe

Detector Type	Internal diameter	Velocity: 2m/s or higher	Velocity: Less than 2m/s
FSSA, C	$\phi 50$ to $\phi 1200$ mm	$\pm 2\%$ of rating	± 0.04 m/s

<High accuracy type>

Plastic pipe and metal pipe

Detector Type	Internal diameter	Velocity: 2m/s or higher	Velocity: Less than 2m/s
FSSA	$\phi 50$ to $\phi 225$ mm	$\pm 1.0\%$ of rating	± 0.02 m/s
FSSC	$\phi 200$ to $\phi 1200$ mm	$\pm 1.0\%$ of rating	± 0.02 m/s

Physical specification

* Please refer to Item 9.3 for special detector
(for small, large diameter pipe and high temperature)

Enclosure protection:

FSSA, FSSC:
IP65 (When waterproof BNC connector is provided)
FSSC (with water proof treatment):
IP68 (submersible in water for 5days)

- Mounting method: Clamp on the pipe surface.
- Acoustic coupler ... The acoustic coupler is a medium that eliminate a gap between detector and the pipe.

<Type of acoustic coupler>

Type	Silicone rubber (KE-348W)	Silicone grease (G40M)	Silicone-free grease (HIGH Z)	Grease for high temperature (KS62M)
Fluid temperature [°C]	-40 to +150	-30 to +150	0 to +60	-30 to +250
Teflon piping	×	○	○	○
Expecting life span (indoor)	5 years	6 months	6 months	6 months

Note: For Teflon piping, silicone rubber is easy to come off.
Thus it is recommended to use the grease.

Material:

Type	Sensor Housing	Sensor cover	Guide rail
FSSA	PBT	—	SUS304
FSSC	PBT	—	Aluminum alloy
FSSD	PBT	—	SUS304
FSSE	PBT	SUS304	Aluminum alloy
FSSH	SUS304	SUS304	Aluminum alloy

Signal cable:

Type: FLYA Transmitter: For FLY-3
Detector: For FSSA, C

- Structure: Heat-resisting high-frequency coaxial cable (3D2V)
- Sheath: Flame-resisting PVC
- Outer diameter: ϕ 5mm
- Termination: Bar terminal (flow transmitter side) and BNC connector (detector side)
- Mass: Approx. 45g/m

Type: FLYD Transmitter: For FSV-2
Detector: FSSA, C, D, E, H

- Structure: Heat-resisting high frequency coaxial cable (double shielding)
- Sheath: Black flame-resisting PVC
- Outer diameter: ϕ 7.3mm
- Terminal treatment

Cable type	FLYD
Applicable detector	FSSA, FSSC, FSSD, FSSH, FSSE
Terminal of transmitter side	Bar terminal x 2 Amplifier terminal (M3) x 1
Terminal of detector side	BNC connector x 1 Amplifier terminal(M4) x1

Mass:

Category	Type	Dimension [mm]	Mass [Kg]
Detector	FSSA	H50 × W348 × D34mm	0.4
	FSSC	H88 × W480 (Max.W880) × D53mm	1.0
	FSSD	H90 × W320 × D52.5mm	0.6
	FSSE	H67 × W78 × D84mm	1.2
	FSSH	H205 × W530 × D52mm	1.6
Signal cable	FLYD	ϕ 7.3mm × according to specified length	Approx. 90g/m
	FLYA	ϕ 5mm × according to specified length	Approx. 45g/m

9.2. Outline diagram

Type: FSSA

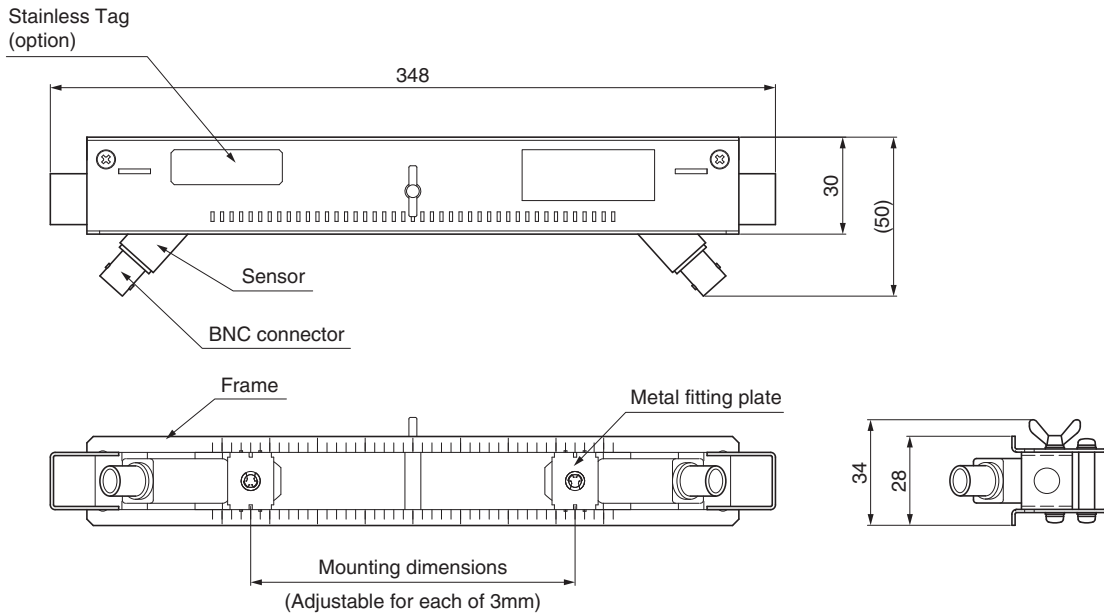

Type: FSSC

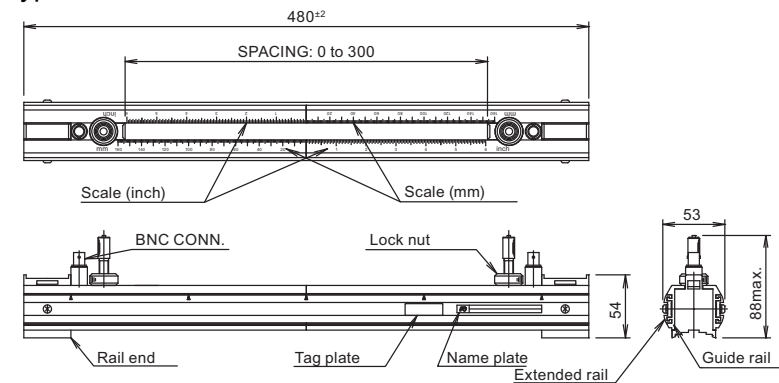

<Shipment style (V method)>

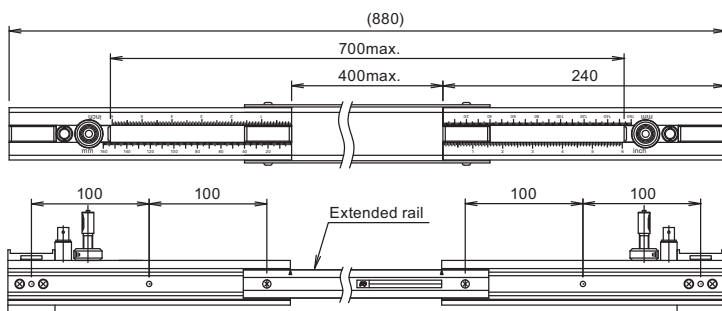

<Extended style (Longest, V method)>

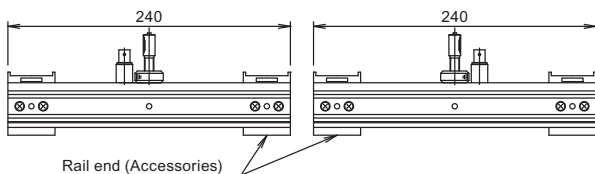

<Separate style (Z method)>

Signal cable : FLYA (FLR-3/FSSA, FSSC)

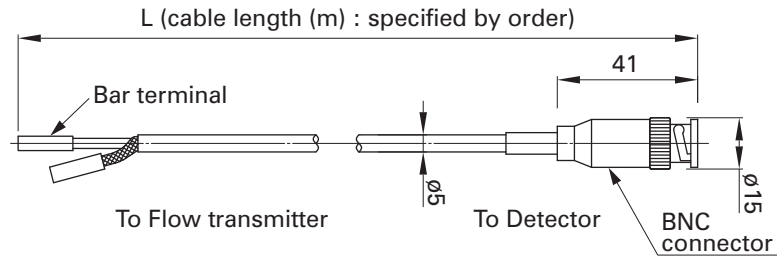

Signal cable : FLYD (FSV-2/FSSA, FSSC, FSSD, FSSH, FSSE)

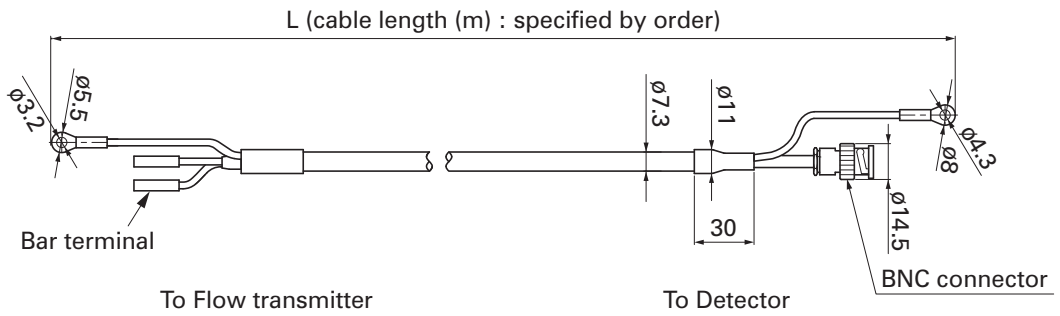

9.3. Detector for special application

(1) detector for small diameter type

Pipe size: $\phi 13$ to 100mm

Fluid temperature: -40 to 100°C

Type: FSSD1□□1-Y□

Specification

- Sensor frequency: 2MHz
- Mounting method: V method
- Fluid temperature: -40 to 100°C
- Applicable pipe material: PVC, SS, carbon steel pipe, copper pipe, aluminum pipe, lining pipe, etc.
[In case lining is removed from the pipe, Measurement can not be conducted]
- Rated accuracy of combination with the flow transmitter (Applicable piping: plastic, metal pipe)

Internal diameter (mm)	Velocity	Accuracy
$\phi 13 \sim \phi 50$	2 to 32m/s	$\pm 1.5\%$ to $\pm 2.5\%$ of rate
	0 to 2m/s	± 0.03 to ± 0.05 m/s
$\phi 50 \sim \phi 100$	2 to 32m/s	$\pm 1.0\%$ of rate
	0 to 2m/s	± 0.02 m/s

- Mounting belt: according to specified code of symbol.
- Material: PBT, guide rail: aluminum alloy + plastic
- Type of enclosure: IP52
- Acoustic coupler: according to specified code of symbol.
- Mass: 0.6kg

OPTIONAL ACCESSORIES

Name	Drawing No.
Silicon grease (GM40M)	ZZP*45231N5
Silicon rubber (KE348W)	ZZP*45735N2
Silicon-free grease (HIGH-Z)	ZZP*TK7M0981P1

OUTLINE DIAGRAM (unit: mm)

<Detector>

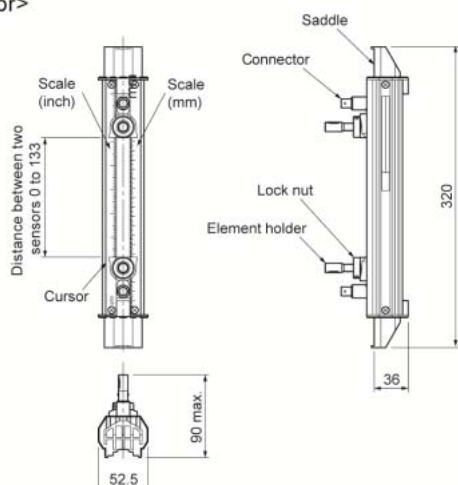

Small diameter sensor: FSSD

<Signal cable>

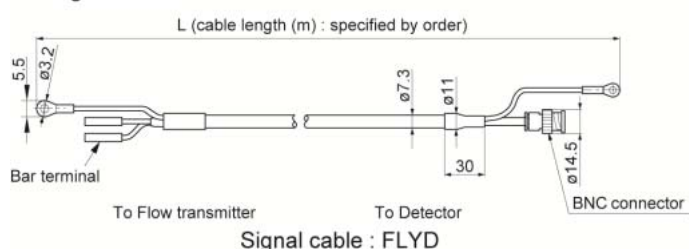

Signal cable : FLYD



CODE SYMBOL

<Detector>

1	2	3	4	5	6	7	8	9	10	Description
F	S	S	D	1						
										<Sensor type> (4th digits) $\phi 13$ to $\phi 100$ mm
										<Guide rail> (5th digits) Provided
										<Mounting belt> (6th digits) None Stainless belt (1.0m x 2) SS belt fasten with screws (1.0m x 4)
										<Acoustic coupler> (7th digit) None Silicon rubber (KE348) Silicone-free grease (HIGH-Z) Silicone grease (G40M)
										<Water-proof treatment> (9th digit) None
										<Tag plate> (10th digit) None Provided

<Signal cable>

1	2	3	4	5	6	7	8	Description
F	L	Y	D				1	
								Type of sensor (4th digit) for FSSA, FSSC, FSSH, FSSD, FSSE
								Cable length (5,6 and 7th digit)
							0 0 5	5 m
							0 1 0	10 m
							0 1 5	15 m
							0 2 0	20 m
							0 2 5	25 m
							0 3 0	30 m
							0 3 5	35 m
							0 4 0	40 m
							0 4 5	45 m
							0 5 0	50 m
							0 5 5	55 m
							0 6 0	60 m
							0 6 5	65 m
							0 7 0	70 m
							0 7 5	75 m
							0 8 0	80 m
							0 8 5	85 m
							0 9 0	90 m
							0 9 5	95 m
							1 0 0	100 m
							1 1 0	110 m
							1 2 0	120 m
							1 3 0	130 m
							1 4 0	140 m
							1 5 0	150 m
							Z Z Z	Others (contact us)

Scope of delivery

- Detector, acoustic coupler and set of the mounting belt according to specified code of symbol
- Signal cable according to specified code of symbol

(2) detector for high temperature

Pipe size: $\phi 50$ to 400mm
 Fluid temperature: -40 to 200°C
 Type: FSSH1□□1-Y□

Specification

- Sensor frequency: 2MHz
- Mounting method: V method ($\phi 50$ to 250mm) or Z method ($\phi 150$ to 400mm)
- Fluid temperature: -40 to 200°C
- Applicable pipe material: PVC, SS, carbon steel pipe, copper pipe, aluminum pipe, lining pipe, etc. [In case lining is removed from the pipe, Measurement can not be conducted]
- Rated accuracy of combination with the flow transmitter (Applicable piping: plastic, metal pipe)

Internal diameter (mm)	Velocity	Accuracy
$\phi 500 \sim \phi 300$	2 to 32m/s	$\pm 1.0\%$ of rate
	0 to 2m/s	$\pm 0.02\text{m/s}$
$\phi 300 \sim \phi 400$	0.75 to 32m/s	$\pm 1.0\%$ of rate
	0 to 0.75m/s	$\pm 0.0075\text{m/s}$

- Mounting belt: according to specified code of symbol.
- Material: sensor housing: SUS304
 guide rail: SUS304 + aluminum alloy
- Type of enclosure: IP52
- Acoustic coupler: according to specified code of symbol.
- Mass: 1.6kg

OPTIONAL ACCESSORIES

Name	Drawing No.
Guide rail for high-temperature sensor (Z method)	ZZP*TK4J5917C3
High-temperature grease(KS62M)	ZZP*TK7P1921C1

OUTLINE DIAGRAM (unit: mm)

<Detector>

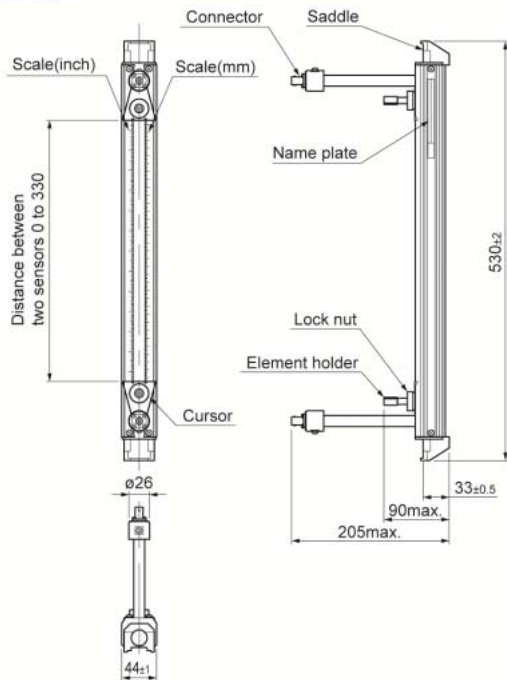

High-temperature sensor: FSSH



CODE SYMBOL

<Detector>

1	2	3	4	5	6	7	8	9	10	Description
F	S	S	H	1	1	-				<Sensor type> (4th digits) $\phi 50$ to $\phi 400\text{mm}$ (-40 to 200°C)
			H							<Guide rail> (5th digits) Provided
				1						<Mounting belt> (6th digits) None Stainless belt (1.0m x 2) SS belt fasten with screws (1.0m x 4)
					Y					<Acoustic coupler> (7th digit) None High-temperature grease (KS62M)
						A				<Water-proof treatment> (9th digit) None
							Y			<Tag plate> (10th digit) None Provided

<Signal cable>

1	2	3	4	5	6	7	8	Description
F	L	Y	D				1	Type of sensor (4th digit) for FSSA, FSSC, FSSH, FSSD, FSSE
			D					Cable length (5,6 and 7th digit)
				0	0	5		5 m
				0	1	0		10 m
				0	1	5		15 m
				0	2	0		20 m
				0	2	5		25 m
				0	3	0		30 m
				0	3	5		35 m
				0	4	0		40 m
				0	4	5		45 m
				0	5	0		50 m
				0	5	5		55 m
				0	6	0		60 m
				0	6	5		65 m
				0	7	0		70 m
				0	7	5		75 m
				0	8	0		80 m
				0	8	5		85 m
				0	9	0		90 m
				0	9	5		95 m
				1	0	0		100 m
				1	1	0		110 m
				1	2	0		120 m
				1	3	0		130 m
				1	4	0		140 m
				1	5	0		150 m
				Z	Z	Z		Others (contact us)

Scope of delivery

- Detector, acoustic coupler and set of the mounting belt according to specified code of symbol
- Signal cable according to specified code of symbol

<Signal cable>

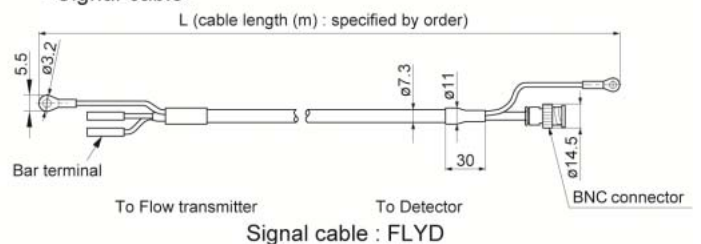

(3) detector for large diameter type

Pipe size: $\phi 200$ to 6000mm
 Fluid temperature: -40 to 80°C
 Type: FSSE1□□1-Y□



Specification

- Sensor frequency: 0.5MHz
- Mounting method: V or Z method
- Fluid temperature: -40 to 80°C
- Applicable pipe material: PVC, SS, carbon steel pipe, copper pipe, aluminum pipe, lining pipe, etc.
 - * In case lining is removed from the pipe, Measurement can not be conducted
- Also applicable to water-proof type according to specified code of symbol (submerged resistant structure for 5days including 10m cable)
- Rated accuracy of combination with the flow transmitter (Applicable piping: plastic, metal pipe)

Internal diameter (mm)	Velocity	Accuracy
$\phi 200 \sim \phi 300$	2 to 32m/s	$\pm 1.5\%$ of rate
	0 to 2m/s	$\pm 0.03\text{m/s}$
$\phi 300 \sim \phi 1200$	0.75 to 32m/s	$\pm 1.5\%$ of rate
	0 to 0.75m/s	$\pm 0.0113\text{m/s}$
$\phi 1000 \sim \phi 6000$	1 to 32m/s	$\pm 1.0\%$ of rate
	0 to 1m/s	$\pm 0.02\text{m/s}$

- Mounting belt: according to specified code of symbol.
- Material: Sensor housing PBT, Sensor cover SUS304
- Type of enclosure: IP67 (silicon rubber is filled up on the terminal block when connecting work)
- IP68 if A (water-proof treatment) is specified at 9th digit of code symbol.
- Acoustic coupler: according to specified code of symbol.
- Mass: 1.2kg

OPTIONAL ACCESSORIES

Name	Drawing No.
Wire rope for mounting the sensor	
• Spring	ZZP*TK745007P1
• Wire rope (up to $\phi 500\text{mm}$)	ZZP*TK464686C1
• Wire rope (up to $\phi 1000\text{mm}$)	ZZP*TK464686C2
• Wire rope (up to $\phi 1500\text{mm}$)	ZZP*TK464686C3
• Wire rope (up to $\phi 3000\text{mm}$)	ZZP*TK464686C6
• Wire rope (up to $\phi 6000\text{mm}$)	ZZP*TK464686C13
Silicon grease (GM40M)	ZZP*45231N5
Silicon rubber (KE348W)	ZZP*45735N2
Silicon-free grease (HIGH-Z)	ZZP*TK7M0981P1

OUTLINE DIAGRAM (unit: mm)

<Detector>

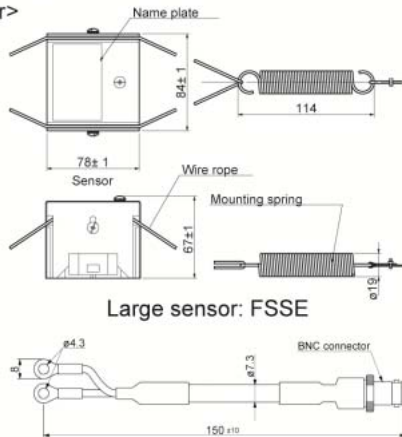

Signal cable conversion cord (accessories)

CODE SYMBOL

<Detector>

1	2	3	4	5	6	7	8	9	10	Description
F	S	S	E	1						<Sensor type> (4th digits) $\phi 200$ to $\phi 6000\text{mm}$
E										<Guide rail> (5th digits) Provided
1										<Mounting belt> (6th digits) None Wire $\leq \phi 1500\text{mm}$ Wire $\leq \phi 6000\text{mm}$
Y										<Acoustic coupler> (7th digit) None Silicon rubber (KE348) Silicon-free grease (HIGH-Z) Silicone grease (G40M)
D										<Water-proof treatment> (9th digit) None Provided (with signal cable 10m)
E										<Tag plate> (10th digit) None Provided
Y										
A										

<Signal cable>

1	2	3	4	5	6	7	8	Description
F	L	Y	D				1	Type of sensor (4th digit) for FSSA, FSSC, FSSH, FSSD, FSSE
D								Cable length (5,6 and 7th digit)
0	0	5						5 m
0	1	0						10 m
0	1	5						15 m
0	2	0						20 m
0	2	5						25 m
0	3	0						30 m
0	3	5						35 m
0	4	0						40 m
0	4	5						45 m
0	5	0						50 m
0	5	5						55 m
0	6	0						60 m
0	6	5						65 m
0	7	0						70 m
0	7	5						75 m
0	8	0						80 m
0	8	5						85 m
0	9	0						90 m
0	9	5						95 m
1	0	0						100 m
1	1	0						110 m
1	2	0						120 m
1	3	0						130 m
1	4	0						140 m
1	5	0						150 m
Z	Z	Z						Others (contact us)

Scope of delivery

- Detector, conversion cord, acoustic coupler and set of the mounting belt according to specified code of symbol
- Signal cable according to specified code of symbol

<Signal cable>

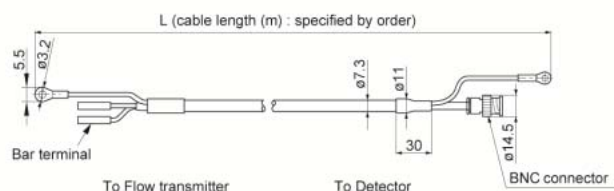

Signal cable : FLYD

9.4. How to make gauge paper

- (1) Provide a sheet of paper (or vinyl) having the length of $4D$ and width of 200 mm (D if possible) or longer, with long sides parallel to each other.

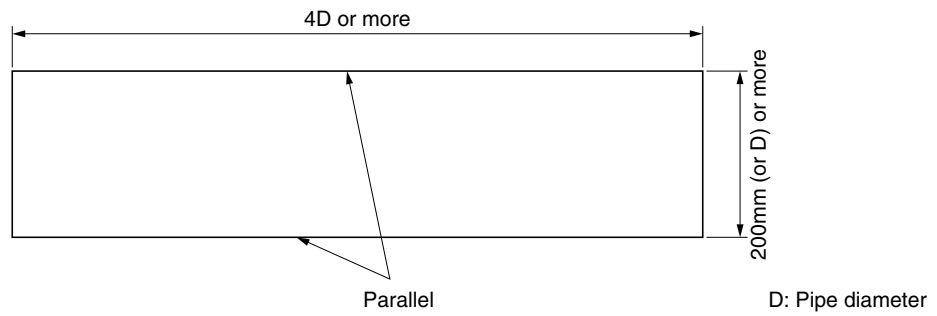

- (2) Draw a line that intersects with the long sides at right angles at a place about 100 mm from one end.



Fuji Electric Co., Ltd.

Global Sales Section

Instrumentation & Sensors Planning Dept.

1, Fuji-machi, Hino-city, Tokyo 191-8502, Japan

<http://www.fujielectric.com>

Phone: +81-42-514-8930 Fax: +81-42-583-8275

<http://www.fujielectric.com/products/instruments/>
