

Integral Ultrasonic Flowmeter <S-Flow>

DATA SHEET

FSZ

This flowmeter is a clamp-on type ultrasonic flowmeter that can measure the volumetric flow rate inside a pipe by clamping on from the outside.

By making full use of the latest electronic and digital signal processing technologies, this flowmeter is significantly smaller than conventional products. It integrates the flow transmitter and detector, enabling it to eliminate the need for signal cable wiring while facilitating mounting to pipes by adopting a greaseless design.

FEATURES

1. Compact and lightweight

Thanks to the adoption of the latest electronics, the flowmeter has achieved an integrated and lightweight design for the flow transmitter and detector.

2. Easy mounting

Its greaseless design makes it easy to mount on piping. Since it integrates the flow transmitter and detector, it eliminates the need for signal cable wiring.

3. Excellent resistance against aerated flow

Its digital signal processing technology has dramatically improved its resistance against aerated flow.

4. High accuracy

It comes standard with an accuracy of $\pm 2.0\%$. By adopting a new sound velocity measurement system, it can measure fluids of unknown sound velocity and suffers negligible impact from pressure.

5. Quick response

It achieves a high-speed response time of 0.5 seconds by utilizing digital signal processing.

6. Excellent performance and easy operation

Its LED and function keys make it easy to perform configurations and troubleshooting.

SPECIFICATIONS

Applications and operating environment

System configuration:

Single-path system using an integrated flow transmitter and detector

Applicable types:

FSZ08, FSZ15, FSZ25

Applicable fluid:

Homogenous liquid where the ultrasonic signal can be transmitted
 Aerated flow: 0 to 12vol% (15A diameter, water, flow velocity 1 m/s)



Applicable piping diameter 8A/10A
(Type: FSZ08)



Applicable piping diameter 15A/20A
(Type: FSZ15)



Applicable piping diameter 25A/32A
(Type: FSZ25)

Fluid turbidity: 10,000 (mg/L) or less
 Flow profile: Fully-developed turbulent or laminar flow in a fully-filled circular pipe

Flow velocity range:

0 to $\pm 0.2 \dots \pm 5$ m/s

Power supply

20 to 27.5 V DC

Installation environment:

Non-explosion-proof area with no direct sunlight, corrosive gas, or radiant heat

Ambient temperature:

During operation: -15 to $+60^\circ\text{C}$
 During storage: -15 to $+65^\circ\text{C}$

Ambient humidity:

95%RH or less with no dew condensation

Applicable piping:

Type	Pipe size(B)
FSZ08	8A, 10A (1/4, 3/8)
FSZ15	15A, 20A (1/2, 3/4)
FSZ25	25A, 32A (1, 1·1/4)

Applicable pipe material:

Metal piping (stainless steel, steel pipes, copper pipes)
 Plastic (PVC, PP, PVDF)

Note 1: Lining pipes are not supported

Note 2: Piping thickness of 1.2 to 4.9 mm

Straight pipe length: Upstream side 10D, downstream side 5D
 (D: Pipe inner diameter). Details depend on straight pipe conditions. (Japan Electric Measuring Instruments Manufacturers' Association JEMIS-032)

Fluid temperature:

-15 to +85°C

When ambient temperature is 50°C or below	Fluid temperature is 85°C or below
When ambient temperature is 50 to 55°C	Fluid temperature is 75°C or below
When ambient temperature is 55 to 60°C	Fluid temperature is 60°C or below

Performance specifications

Rated accuracy:

Flow rate of 1 m/s to 5 m/s	Flow rate of less than 1 m/s
±2.0% of rate	±0.02 m/s

Note) Accuracy in water at 20°C (standard)

Response time:

0.5 s

Power consumption:

2.5 W or less

Functional specifications

Analog signal:

4 to 20 mA DC: 1 signal

Load resistance: 550 Ω max.

Digital output:

Forward total and alarms can be assigned as desired
 Transistor contact (open collector)

- Outputs: 2
- Normal: ON/OFF selectable
- Contact capacity: 27.5 V DC, 100 mA
- Output frequency: Max. of 100 P/s
 (Pulse width of 5, 10, 50, 100, 200 ms)

Temperature measurements (optional):

Pipe surface temperature measurement accuracy:

±2°C (at an ambient temperature of 20°C)

Measurement range: -15 to +85°C

Display device:

LED display, 4-digit, 7-segment, 2-line

Status LED (green when normal, red when abnormal)

Flow direction LED (setting)

Flow rate indication:

Instantaneous flow rate indication

(minus indication for reverse flow)

Numbers: 4 digits (excluding decimal point)

Unit: L/min, gal/min

Total indication:

Forward total value indication

Numbers: 8 digits (no decimal point)

Unit: L, gal

Configuration:

Three keys (UP, DOWN, ENTER)

Zero adjustment:

Set zero / clear zero

Damping:

0, 1, 3, 5, 10, 30, 60, 90 s for analog output and flow rate display

Low flow rate cutoff:

Low flow rate cutoff value can be set as desired

Alarm:

Hardware or process abnormalities

Contact output available

Burnout:

Analog output: Hold/Overscale/Underscale/Zero selectable

Burnout timer: 10 to 900 s (every 1 s)

Total reset:

Total value can be set to zero

Backup of power failure:

Backup by non-volatile memory

Physical specifications

Type of enclosure:

IP65/IP67

When connected to dedicated signal cable

Mounting method:

Clamped on pipe surface

Material:

Plastic (PPS, PC, PPO), rubber, stainless steel

Signal cable:

Type: FLYF

- Material: Polyurethane (PUR)
- Outer diameter: ø6 mm
- Cable length: 3 m, 10 m
- Termination:

Flowmeter body side: M12, 8-pin connector

Connection point: No terminal processing

Flowmeter body size:

FSZ08: Max. of H65×W120×D42 mm

FSZ15: Max. of H75×W120×D50 mm

FSZ25: Max. of H90×W120×D68 mm

Mass:

FSZ08: 400 g

FSZ15: 500 g

FSZ25: 600 g

EU Directive Compliance

CE

EMC (2014/30/EU)

EN 61326-1 (Table 2)

EN 61326-2-3

RoHS (2011/65/EU) + (EU)2015/863

EN IEC 63000:2018

UK
CA

EMC (S.I.2016 No.1091)

EN 61326-1 (Table 2)

EN 61326-2-3

RoHS (S.I.2012 No.3032)

EN IEC 63000:2018

MEASURING PRINCIPLE

With ultrasonic pulses propagated diagonally between the upstream and downstream sensors, flow rate is measured by detecting the time difference obtained by the flow of fluid.

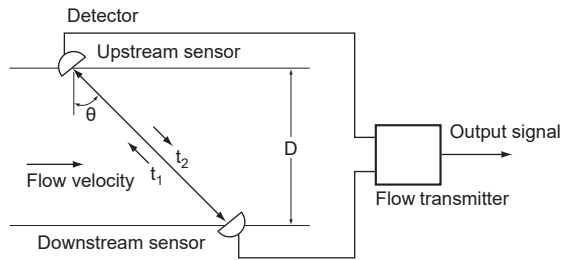

CONFIGURATION DIAGRAM

Single-path system (V method)

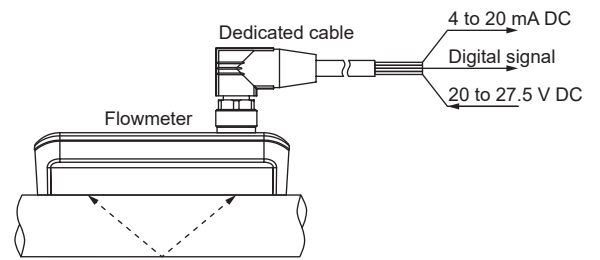

Straight pipe conditions

(D: inside diameter of pipe)

Classification	Upstream side	Downstream side
90° bend		
Tee		
Diffuser		
Reducer		
Various valve	 In the case where a flow control valve exists on upstream side	 In the case where a flow control valve exists on downstream side
Pump		

(Note) The source: JEMIS-032

CODE SYMBOL

(Flowmeter body)

1	2	3	4	5	6	7	8	Description
F	S	Z					1	Diameter (4th, 5th digit) 8A, 10A (1/4B, 3/8B)
			0	8				15A, 20A (1/2B, 3/4B)
			1	5				25A, 32A (1B, 1·1/4B)
			2	5				Power supply (6th digit) 20 to 27.5 V DC
					Y			Flowmeter option (7th digit) None
						Y		Pipe temperature measurement
						T		Revision No. (8th digit)
							1	

(Dedicated signal cable)

1	2	3	4	5	6	7	8	Description
F	L	Y					1	Application (4th digit) Integral Ultrasonic Flowmeter <FSZ>
			F					Dedicated signal cable length (5, 6 and 7th digit) 3 m
				0	0	3		10 m
				0	1	0		Revision No. (8th digit)
							1	

Other items (Auxiliary parts)

	Name	Specifications	Order type
1	Mounting bracket 8A, 10A	SUS	ZZP*TQ407651P01
2	Mounting bracket 15A, 20A	SUS	ZZP*TQ407652P01
3	Mounting bracket 25A, 32A	SUS	ZZP*TQ407809P01
4	Fixing screw set 8A, 10A	M4x11, SUS, retaining washers (4 pcs.)	ZZP*TQ509186C01
5	Fixing screw set 15A, 20A	M4x14, SUS, retaining washers (4 pcs.)	ZZP*TQ509186C02
6	Fixing screw set 25A, 32A	M5x20, SUS, retaining washers (4 pcs.)	ZZP*TQ509186C03
7	Acoustic coupler	Special plate	ZZP*TQ508768P01

*Required quantity: 1 per unit

OUTLINE DIAGRAM (Unit:mm)

(Flowmeter body)

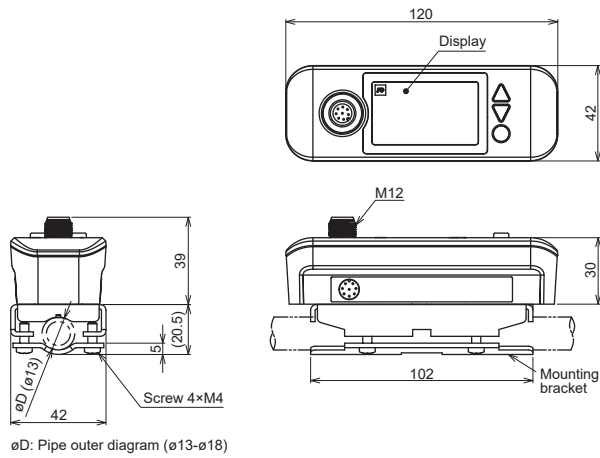

Type: FSZ08

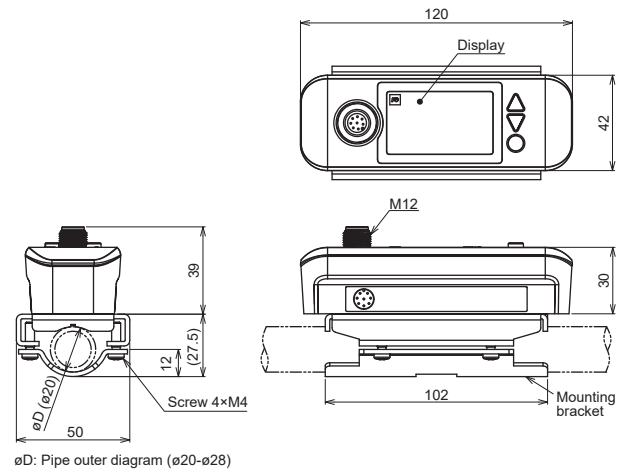

Type: FSZ15

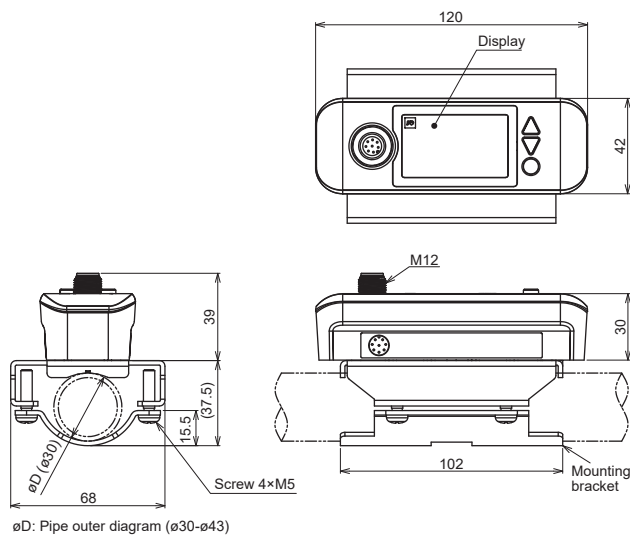

Type: FSZ25

<Dedicated cable>

Type	FLYF003	FLYF010
L [m]	3 ± 0.15	10 ± 0.2

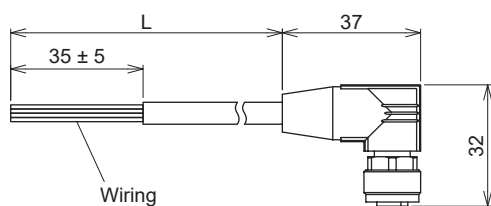

* For connections, see the section on External Connections on the next page.

External connection

Connection name	Wiring
Power supply	[5] Gray (GRY) — (+) 20-27.5 Vdc [8] Red (RED) — (-)
Current output	[3] Green (GRN) — (+) 4-20 mA [2] Brown (BRN) — (-)
Digital output 1	[4] Yellow (YEL) — (+) 27.5 Vdc max., [8] Red (RED) — (-) 0.1 A max.
Digital output 2	[6] Pink (PNK) — (+) 27.5 Vdc max., [8] Red (RED) — (-) 0.1 A max.
No connection	[7] Blue (BLU) — NC (RESERVED) [1] White (WHT) — NC (RESERVED) [8] Red (RED) — (GND)

SCOPE OF DELIVERY

- Flowmeter body
- Dedicated cable
- User-friendly instruction manual
- Precautions

ITEMS DESIGNATED ORDERING

1. Designation of flowmeter body type
2. Designation of dedicated cable type

Items to check before purchasing

The following conditions may cause measurement failures or reduction in accuracy for the flowmeter.

Please consult and ask Fuji Electric in advance when checking actual equipment if you have any concerns regarding application.

1) Fluid

- If fluid contains a large amount of bubbles (approx. 12 vol% or more at 1 m/s flow rate)
- If fluid has bad turbidity 10000 (mg/L) or more
- If fluid contains slurry or solid materials (about 5 wt%)
- If flow rate is low Reynolds No.10000 or less
(Reference: Flow rate 1.5 L/min at 32A)
*Flow rate is proportional to the diameter
- If it is circulating oil, low-concentration chemical solutions, waste liquids, hot spring water, etc.

2) Piping

- Roughened carbon steel pipe with a rusty inner surface.
- Pipe with adhering substances and sediment on the inside.
- Pipe with roughened outer surface.
- Plastic piping with thick walls (5 mm or more)
- If it is SGPW pipe,
- If it is rubber pipe,

3) Length of the straight pipe

For accurate measurements, adequate straight pipe lengths are needed between the up and down stream side of the measuring part. Please meet the straight pipe conditions described in page 3.

Caution on use

- 1) Do not damage the flowmeter or the dedicated cable.
- 2) Make sure to fill the fluid inside the pipe to be measured.
- 3) When you use a horizontal pipe, we recommend mounting the flowmeter horizontally.
- 4) When the flowmeter is installed outdoors, we recommend mounting a waterproof cover to protect it from direct sunlight to prevent deterioration.
- 5) Use an insulated, ungrounded, regulated power supply.
- 6) Connect an insulated, ungrounded device to the analog current output and contact output.

Information in this catalog is subject to change without notice.
Read the instruction manuals thoroughly before using the products.



Gate City Ohsaki, East Tower, 11-2, Osaki 1-chome, Shinagawa-ku, Tokyo 141-0032, Japan
Phone: +81-3-5435-7111
www.fujielectric.com
www.fujielectric.com/products/instruments/