

NDIR GAS ANALYZER FOR STACK GAS

DATA SHEET

ZSJ

OVERVIEW

This analyzer consists of an infrared gas analyzer, an O₂ sensor and a gas sampling device. It is used for simultaneous and continuous measurement of the NO_x, SO₂, CO, CO₂ and O₂ components in the flue gas of various boilers, garbage incinerators, etc.

For CO and O₂ measurement specifications, the function for coping with the Japanese regulation on dioxin emission is incorporated.

FEATURES

- Gas concentrations of 5 components is measurable simultaneously and continuously
NO_x, SO₂, CO and CO₂ gas concentration measurements are integrated by infrared method, to which a zirconia or magnetic type O₂ sensor is added for O₂ measurement. Therefore, the gas concentrations of 5 components are simultaneously and continuously measurable.
- Zero drift does not occur as a principle thanks to high sensitive and reliable mass flow sensor is equipped and switching^(Note 1) method is adopted.
- Maintenance can be performed from the front side, thus saving the installation space.
Unitized structure of the analyzing block and gas sampling module enables better maintenance.
- Provided with abundant functions including O₂ correction output, average value output, automatic calibration, CO peak count alarm, automatic range changeover, and alarms.

(Note 1) Alternately sending sample gas and reference gas into the measurement block, ensuring long-term stability.

SPECIFICATIONS

Standard Specifications

Measuring system:

NO_x, SO₂, CO and CO₂ ; Ndir type infrared

O₂ ; Zirconia type, magnetic type

Measurable component and min./max. measurement range:

NO_x ; 0 to 50 ppm/0 to 5000 ppm

SO₂ ; 0 to 50 ppm/0 to 5000 ppm

CO ; 0 to 50 ppm/0 to 5000 ppm

CO₂ ; 0 to 10 %/0 to 20%

O₂ ; 0 to 10 %/0 to 25%

Number of measurement ranges:

2 Maximum range ratio: 1:10 (Refer to Code Symbols.)

Warm-up time:

Within 4 hours after power-on



Analog output signals:

Simultaneous output of signals of 4 to 20 mA DC each (non-isolated or isolated depending on customer's code selection)

- Five instantaneous value outputs (NO_x, SO₂, CO, CO₂ and O₂)
- Three instantaneous values (NO_x, SO₂, CO) after O₂ correction when provided with O₂ sensor
- Three average values (NO_x, SO₂, CO) after O₂ correction when provided with O₂ sensor
- Allowable load resistance: 550 Ω or less

Contact output:

(1) Each SPST contact (contact capacity 250 V AC, 2 A or 30 V DC, 3 A) for:

- Range identification of each component (Close/1st range), analyzing block error, calibration error, auto calibration status, maintenance status, and CO peak count alarm

(2) Each SPDT contact (contact capacity 250V AC, 1 A or 30 V DC, 1 A) for:

- Concentration alarm for each component's instantaneous value (H, L, HL settable), analyzing block power off

Contact input:

Non-voltage contact (1.5 sec or longer)

- Auto calibration start, average value resetting

Non-voltage contact (Status holded)

- Range changeover (1st range when contact closes), output hold, remote aspirator OFF (OFF when contact closes)

Indication:

LCD with back light for indicating:

- Instantaneous values (NO_x, SO₂, CO, CO₂ and O₂)
- O₂ corrected instantaneous values (NO_x, SO₂, CO) after O₂ correction when provided with O₂ sensor
- O₂ corrected average values (NO_x, SO₂, CO) after O₂ correction when provided with O₂ sensor
- O₂ average value when provided with O₂ sensor
- Peak count value (when provided with CO, O₂ analyzer)
- Parameter assignment

Fluorescent lamp in cubicle:

Standard equipment

Recorder (option):

Paperless recorder (Fuji Electric's type PHR) mounted

Gas extractor:

Electrical heating type (filter built in)

- Wire mesh filter : 40µm mesh of SUS 316 stainless steel
- Flange : JIS 5K 65AFF
- Mass: Approx. 9 kg (excluding gas sampling pipe)
- Power supply voltage: 100 V AC, 50/60 Hz
- Power consumption: Approx 100 VA
- Sampling pipe: Refer to Code Symbols for materials and length of the pipe.
SUS 316 (length 300, 400, 600, 800, 1000 mm), or titanium (length 600, 800, 1000 mm), or SiC (length 700, 900 mm)
- *SUS 316 is used for 800°C or lower.
- *Titanium is used for 1000°C or lower.
- *SiC is used for 1300°C or lower.

Sample inlet tube:

ø10/ø8 Teflon tube or heating tube (max. 30 m)

*The heating tube needs to be specified in the following cases.

- (1) Ambient temperature -5°C or lower
- (2) SO₂ of 0 to 50 ppm or 0 to 100 ppm
- (3) Tube length 10 m or longer in SO₂ measurement
(Power supply voltage: 100 V AC, 50/60 Hz, power consumption: 36 VA/m)

Rated operating conditions:

- Ambient temperature: -5 to 40°C (depending on customer's code selection)
- Ambient humidity: 90% RH or less
- Power supply voltage: 100, 110, 115, 200 or 230 V AC ±10%
(depending on customer's code selection)
- Frequency: 50 or 60 Hz ±0.5 Hz
- Power consumption: Max. 900 VA
(excluding gas extractor and heating tube)

Storage condition:

- Ambient temperature; -20 to 60°C (Water within the drain pot should be drained before storage.)
- Ambient humidity; 95%RH or lower

Dry air:

Dew point; -20°C DP or lower

Pressure; 100 kPa to 400 kPa

Dust and mist; None

External dimensions (H x W x D):

Indoor type; 1710 × 800 × 615 mm

Outdoor type; 1780 × 815 × 700 mm

Mass:

Approx. 300 kg (excluding standard gas)

Cubicle finish color:

Munsell 5Y7/1 semi-gloss

Cubicle structure:

Indoor or outdoor installation, of selfstanding type, single-swing front door, plate thickness 2.3 mm standard (both cubicle and door)

Other:

Six standard gas cylinders (3.4 L) accommodatable

Measurement Law type approval No.:

SAN181(NO_x analyzer)

SAS182(SO₂ analyzer)

SAC182(CO analyzer)

SE171(Zirconia O₂ sensor)

SF172(Magnetic O₂ sensor)

Standard Functions

Function	Description
O ₂ Correction	<ul style="list-style-type: none"> Conversion of measured NO_x, SO₂ and CO gas concentrations into values at standard O₂ concentration <p style="margin-left: 20px;">Calculating equation : $C = \frac{Cs(21-O_N)}{21-O_s}$</p> <div style="display: flex; justify-content: space-between; margin-left: 20px;"> <div> <p>C : Sample gas concentration after O₂ correction</p> <p>C_s : Measured concentration of sample gas</p> <p>O_s : Measured O₂ concentration</p> <p>O_N : Standard O₂ concentration (4% for petroleum fuel, 5% for gas fuel, 6% for coal fuel, 12% for garbage incinerator)</p> <p>Setting range: 0 to 19%</p> </div> <div> <ul style="list-style-type: none"> The result of conversion is indicated and output in a signal of 4 to 20 mA DC. </div> </div>
Auto Calibration	<ul style="list-style-type: none"> The gas analyzer is automatically calibrated. Auto calibration cycle settable range: 1 to 99 hours (1-hour step) or 1 to 40 days (1-day step) Auto calibration gas injection time settable range: 60 to 599 seconds (in 1-sec step) Auto/manual calibration error contact output: Provided when calibration quantity exceeds 50% of full scale. Contact output during auto calibration and maintenance: Provided during calibration gas flow and replacement. Also provided during maintenance. Auto calibration remote start contact input: Calibration starts at opening after short-circuit for 1.5 sec or longer. Standard gas consumption: Approx. 1 year with 3.4L cylinder in a calibration cycle of 7 days
Average Value after O ₂ Correction, O ₂ average value	<ul style="list-style-type: none"> NO_x, SO₂ and CO values are averaged after O₂ correction, and the result is indicated and output in 4 to 20 mA DC. Averaging time is settable by key operation at the front of analyzing block. Settable range: 1 to 59 minutes or 1 to 4 hours (factory-set at 1 hour)
Remote Output Hold	<ul style="list-style-type: none"> The output signal values are collectively held according to external contact input. Output is held during short-circuit.
Average Value Resetting Input	<ul style="list-style-type: none"> Output and indication of average value after O₂ conversion are reset according to external contact input. Output and indication are reset at short-circuit for 1.5 sec or longer.
Automatic range changeover	<ul style="list-style-type: none"> Automatically changed from low range to high range, and from high range to low range. Low → High: Changed at 90% point of the low range High → Low: Changed at 80% point of the high range
Remote range Changeover Input	<ul style="list-style-type: none"> Low or high range is selectable for each sample component via external contact input. High range is selected for open-circuit, and low range for short-circuit.
Range Identification Contact Output	<ul style="list-style-type: none"> Identification between low and high ranges is output through a contact. When the contact is closed, low range is selected.
Concentration Alarm Contact Output	<ul style="list-style-type: none"> Instantaneous value alarm is settable for each sample component. High, Low, High or Low is settable (by keys at the front of analyzing block). Contact output hysteresis is also settable. Contact is 1c type.
CO Instantaneous Value Peak Count Alarm Contact Output	<ul style="list-style-type: none"> Alarm is issued and indicated when CO instantaneous value has exceeded the set limit by the set number of times. Settable number of times: 1 to 99, alarm settable range: 10 to 1000 ppm (5 ppm step) The number of overshootings per hour is indicated.
Analyzing Block Error Contact Output	<ul style="list-style-type: none"> Contact output is provided when the analyzing block is abnormal.
Temperature Input Signal	<ul style="list-style-type: none"> K thermocouple input x 2 (for recorder available at option)

Performance**Repeatability:**

±0.5% of full scale

Zero drift:

±1.0% of full scale or lower/week

Max. ±2.0% of full scale/month on Zirconia O₂ sensor

Span drift:

Max. ±2.0% of full scale/week

Max. ±2.0% of full scale/month on Zirconia O₂ sensor

Linearity:

Max. ±1.0% of full scale

Response time:

For 90% indication (after extracting sample gas through the inlet)

NO_x : 120 sec or shorter

SO₂ : 240 sec or shorter

CO : 120 sec or shorter

CO₂ : 120 sec or shorter

O₂ : 120 sec or shorter

Sample gas flow rate:

Approx. 3L/min

Standard Requirements for Sample Gas**Temperature:**

Standard : 60 to 800°C

Non standard: 1000°C (titanium probe)

1300°C (SiC probe)

Dust:

100 mg/Nm³ or less

Pressure:

-5k to +5kPa

Components:

SO₂ : 500 ppm or less

NO_x : 1000 ppm or less

CO₂ : 0 to 15%

CO : 2000 ppm or less

O₂ : 1 to 21%

HCL : 100 ppm or less

The remaining : N₂, H₂O

Installation Requirements

- (1) Selection of a place which does not receive direct sunlight or radiation from hot substances
If such a place cannot be found, a roof or cover should be prepared for protection.
- (2) Avoidance of a place under heavy vibration
- (3) Selection of a place where atmospheric air is clean

SCOPE OF DELIVERY

- Gas analyzer system
- Specified external drain separator/drain pot
- Specified gas extractor/probe set
- Specified gas inlet tube set
- Standard accessories

ITEMS TO BE PREPARED SEPARATELY

1. Standard gas and pressure regulator
(Refer to ZSY of CODE SYMBOLS)
2. Recorder (when necessary) type PHR
3. Individual inspection of measurement method
4. 1-year spare (Refer to ZBN of CODE SYMBOLS)
5. Waterproof gland for outdoor wiring port (A25A),
Order No.: 8641625
6. Anchor bolt

5-Component Gas Sampling System Diagram (Standard type)

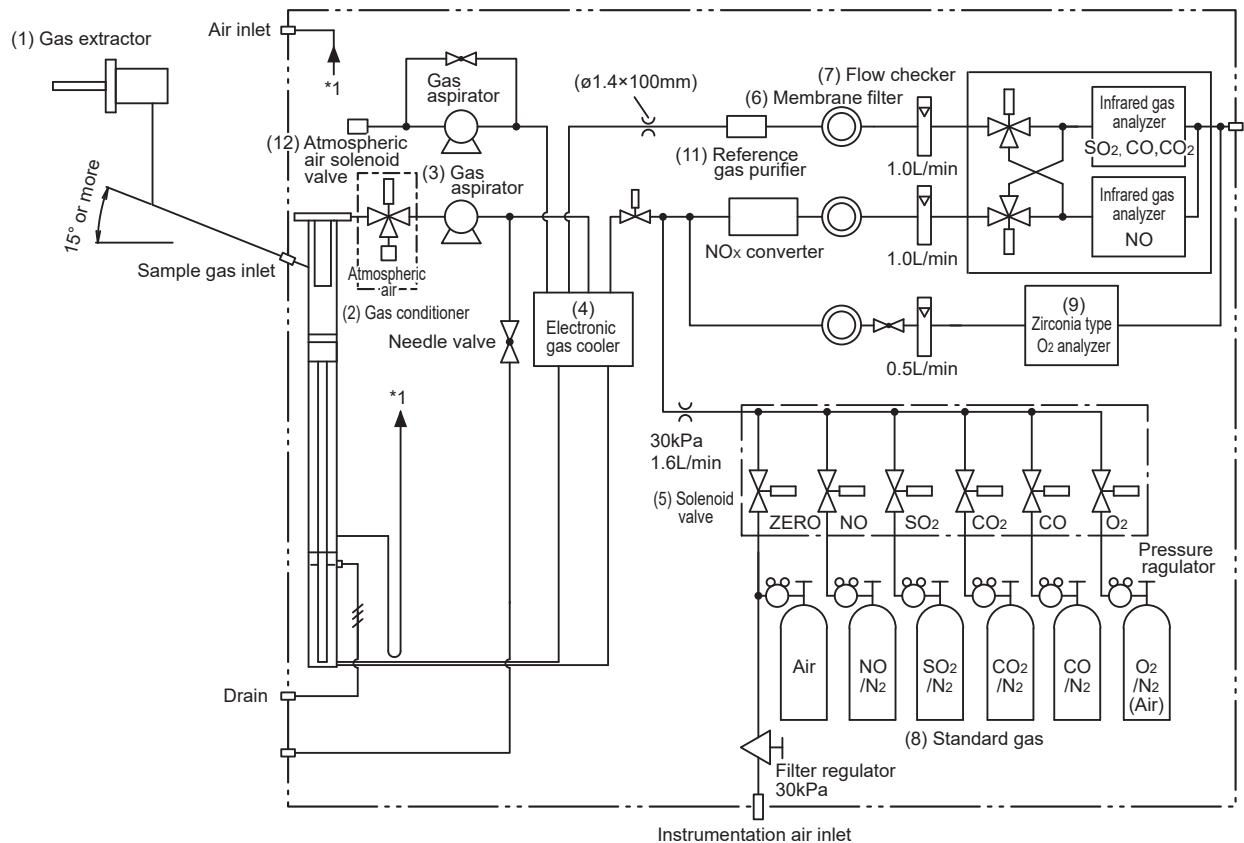

Functions of Individual Components

- | | |
|---|---|
| <p>(1) Gas extractor: Gas extraction, with heating type stainless steel filter having a standard diameter of 40μm</p> <p>(2) Gas conditioner: Removes drain, mist and dust, and monitors the gas pressure.</p> <p>(3) Gas aspirator: Aspirates sample gas (Flow rate of sample gas: Approx. 3L/min)</p> <p>(4) Electronic gas cooler: Dries the moisture in the sample gas.</p> <p>(5) Solenoid valve: Used for introducing calibration gas.</p> <p>(6) Membrane filter: PTFE filter, glassfiber filter used to eliminate fine dust particles and permit monitoring of dust adhering condition on the gas analyzer.</p> <p>(7) Flow checker: Monitors the flow rate of sample gas and reference gas (it can be controlled by the separate needle valve.)</p> | <p>(8) Standard gas: Reference gas used for calibrating zero and span of the analyzer. Up to 6 gases (Zero gas air, span gas NO_x, SO₂, CO₂, CO and O₂) can be used.</p> <p>(9) O₂ sensor: Used for measuring the oxygen concentration (0 to 25%) in sample gas.</p> <p>(10) Converter: Added to NO_x analyzer. A special catalyst material for efficient conversion of NO₂ gas to NO is used.</p> <p>(11) Reference gas purifier: converter which refine air into the reference gas. (When CO meter is provided)</p> <p>(12) Atmospheric air solenoid valve: Can be built in for using the atmospheric air instead of standard air.</p> |
|---|---|

External Terminal Connection Diagram

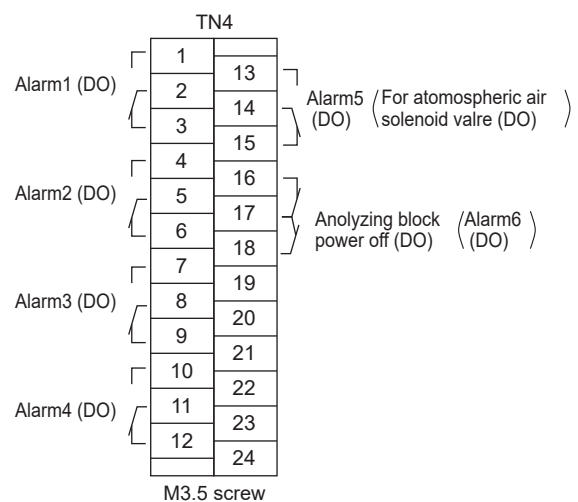
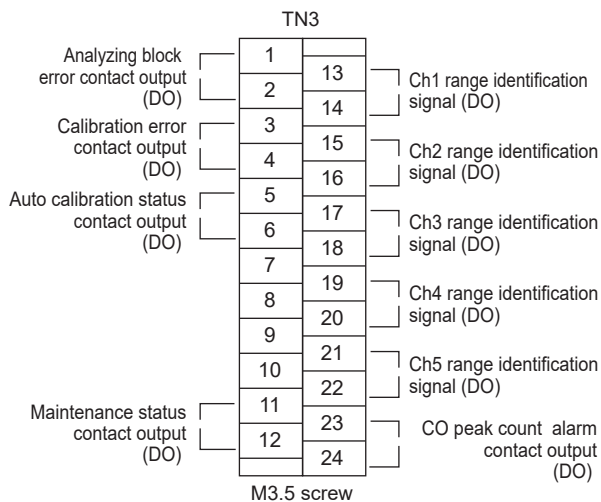
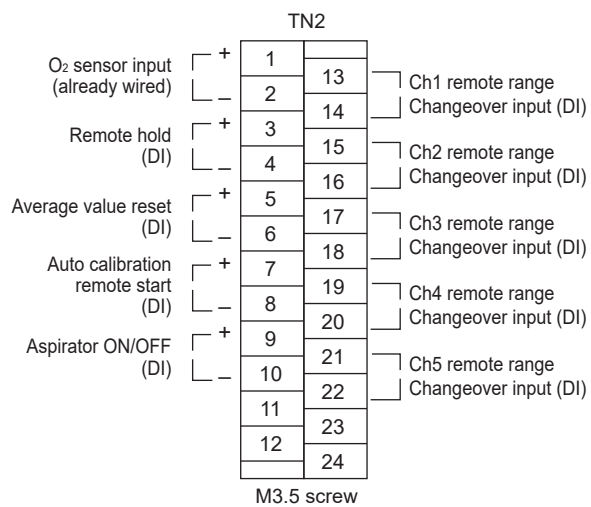
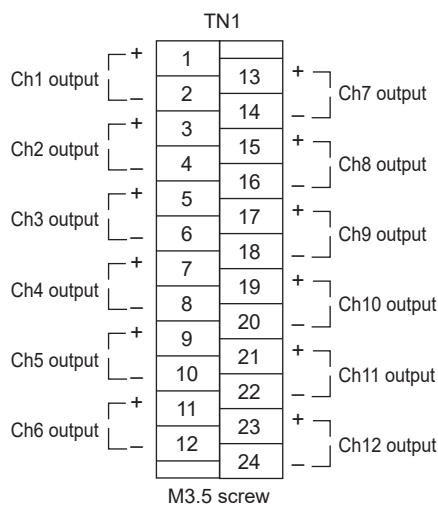
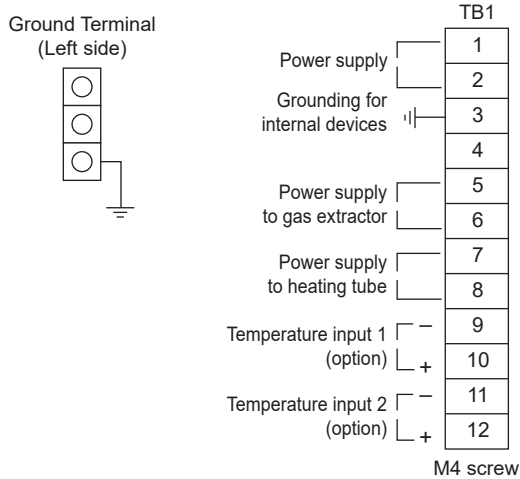

External terminal block diagram (Upper side of main unit)

TB1	TN1	TN2	TN3	TN4
1	1	13	1	13
2	2	14	2	14
3	3	15	3	15
4	4	16	4	16
5	5	17	5	17
6	6	18	6	18
7	7	19	7	19
8	8	20	8	20
9	9	21	9	21
10	10	22	10	22
11	11	23	11	23
12	12	24	12	24

Contents of Measured Channel (CH)

The following table gives the contents of each output signal according to code symbols.

Code symbol		Contents
4th digit	5th digit	
P	0	Ch1: NO _x
A	0	Ch1: SO ₂
B	0	Ch1: CO
F	0	Ch1: NO _x , Ch2: SO ₂
H	0	Ch1: NO _x , Ch2: CO
L	0	Ch1: NO _x , Ch2: SO ₂ , Ch3: CO
M	0	Ch1: NO _x , Ch2: SO ₂ , Ch3: CO ₂ , Ch4: CO
P	4 to G	Ch1: NO _x , Ch2: O ₂ , Ch3: Corrected NO _x , Ch4: Corrected NO _x average
A	4 to G	Ch1: SO ₂ , Ch2: O ₂ , Ch3: Corrected SO ₂ , Ch4: Corrected SO ₂ average
B	4 to G	Ch1: CO, Ch2: O ₂ , Ch3: Corrected CO, Ch4: Corrected CO average
F	4 to G	Ch1: NO _x , Ch2: SO ₂ , Ch3: O ₂ , Ch4: Corrected NO _x , Ch5: Corrected SO ₂ , Ch6: Corrected NO _x average, Ch7: Corrected SO ₂ average
H	4 to G	Ch1: NO _x , Ch2: CO, Ch3: O ₂ , Ch4: Corrected NO _x , Ch5: Corrected CO, Ch6: Corrected NO _x average, Ch7: Corrected CO average
L	4 to G	Ch1: NO _x , Ch2: SO ₂ , Ch3: CO, Ch4: O ₂ , Ch5: Corrected NO _x , Ch6: Corrected SO ₂ , Ch7: Corrected CO, Ch8: Corrected NO _x average, Ch9: Corrected SO ₂ average, Ch10: Corrected CO average
M	4 to G	Ch1: NO _x , Ch2: SO ₂ , Ch3: CO ₂ , Ch4: CO, Ch5: O ₂ , Ch6: Corrected NO _x , Ch7: Corrected SO ₂ , Ch8: Corrected CO, Ch9: Corrected NO _x average, Ch10: Corrected SO ₂ average, Ch11: Corrected CO average

Standard Accessories

No.	Name	Quantity	Remarks
1	Filter paper for membrane filter/as spare (Teflon)	6 sheets	When SO ₂ meter is provided (Note) When SO ₂ meter is not provided
	Filter paper for membrane filter (25 sheets for per box) / as spare (glass fiber)	1 box	
2	Standard gas joint Rc1/4 - ø6mm	1 set	} When gas extractor is equipped When heating tube is equipped
3	Hose band for fixing standard gas cylinder	1 set	
4	Toaron tube for standard gas connection, 1 m and ø9 / ø5mm	1 tube	
5	Polyethylene tube for standard gas connection, 6 m and ø6 / ø4mm	1 tube	
6	Anchor bolt for cubicle installation, (Option) M12 × 160 × 50	4 psc	
7	Water bottle for injection	1 psc	
8	Gas sampling pipe flange packing	1 psc	
9	Gas extractor fastening bolt and nut (M12×60mm)	1 set	
10	Heating tube support	1 set	
11	Instruction manual (INZ-TN2ZSJ-E)	1 copy	

Note) When Zirconia O₂ meter is not provided, 4 sheets.

Spare Parts for 1-Year Measurement

- Filter paper for membrane filter (teflon) 6 sheets x 1
 - Membrane filter O-ring (G65) x 3
 - Membrane filter rubber-ring x 3
 - Filter element for conditioner filter x 2
 - O-ring (G65) for conditioner filter x 2
 - Diaphragm for gas aspirator x 2
 - Valve for gas aspirator x 2
 - Capillary for $\varnothing 1.4\text{mm} \times 100\text{mm}$ x 1
 - O-ring for gas extractor (G50) x 1
 - Packing for gas extractor wire mesh filter x 1
 - Wire mesh filter packing for gas extraction x 1
 - O-ring (G45) for gas extraction x 1
 - NOx/NO converter catalyst x 1
 - Glass wool for NO₂/NO converter x 1
 - Fitting for NO₂/NO converter x 2
 - Reference gas purifier catalytic x 1
 - Glass wool for reference gas purifier (Note2) x 1
 - Coupler for reference gas purifier x 2 (Note2)
- } Added when gas extractor is equipped
- } Added when NOx analyzer is equipped
- } Added when CO analyzer is equipped

(Note 1) Filter paper for membrane filter (glass fiber) 25 sheets for per box except for SO₂ meter x 1

(Note 2) Use the same kind of stuff for NO₂/NO convertor

Code Symbols for Spare Parts for 1-Year Measurement

1 2 3 4 5 6 7 8								Description			
Z	B	N	1	S	J		2	(Gas extractor)	(NOx analyzer)	(SO ₂ analyzer)	(CO analyzer)
0	----	Without		Without		Without		Without		With	
1	----	With		Without		Without		Without		With	
2	----	Without		With		Without		Without		With	
3	----	With		With		Without		Without		With	
A	----	Without		Without		With		With		With	
B	----	With		Without		With		With		With	
C	----	Without		With		With		With		With	
D	----	With		With		With		With		With	
J	----	Without		Without		Without		Without		Without	
K	----	With		Without		Without		Without		Without	
L	----	Without		With		Without		Without		Without	
M	----	With		With		Without		Without		Without	
N	----	Without		Without		With		With		Without	
P	----	With		Without		With		With		Without	
Q	----	Without		With		With		With		Without	
R	----	With		With		With		With		Without	

STANDARD GAS CODE SYMBOLS

1	2	3	4	5	6	7	8	9	10	11	Description
Z	S	Y					2				
								0			NO _x measurement first range <4th digit>,ppm Without
								A			50
								1			100
								2			200
								3			250
								4			500
								5			1000
								6			2000
								7			5000
								0			SO ₂ measurement first range <5th digit>,ppm Without
								A			50
								1			100
								2			200
								3			250
								4			500
								5			1000
								6			2000
								7			5000
								0			CO measurement first range <6th digit>,ppm Without
								A			50
								1			100
								2			200
								3			250
								4			500
								5			1000
								6			2000
								7			5000
								Y			CO ₂ measurement first range <7th digit>,ppm Without
								A			5
								B			10
								C			20
								0			O ₂ span gas <9th digit> Without
								1			1.8 to 2% O ₂ / N ₂
								2			10% O ₂ / N ₂ Note)
								3			AIR
								Y			Zero gas <10th digit> Without
								A			Air cylinder (without certificate)
								B			Air cylinder (with certificate Japanese official organization)
								C			N ₂ cylinder (without certificate)
								D			N ₂ cylinder (with certificate)
								Y			Offical certificate <11th digit> Without
								A			NO _x
								B			SO ₂
								C			CO
								D			NO _x , SO ₂
								E			NO _x , CO
								F			NO _x , SO ₂ , CO
								G			NO _x , O ₂
								H			SO ₂ , O ₂
								J			CO, O ₂
								K			NO _x , SO ₂ , O ₂
								L			NO _x , CO, O ₂
								M			NO _x , SO ₂ , CO, O ₂

Note: Select "1" for the 9th digit and "A" or "B" for the 10th digit for zirconia type O₂ sensor.
For the magnetic type O₂ sensor, select "2" or "3" for the 9th digit according to the selection of the first range, and select "C" or "D" for the 10th digit.

Scope of Delivery: standard gas (3.4L) with pressure regulator

OUTLINE DIAGRAM (Unit: mm)

<Gas extractor>

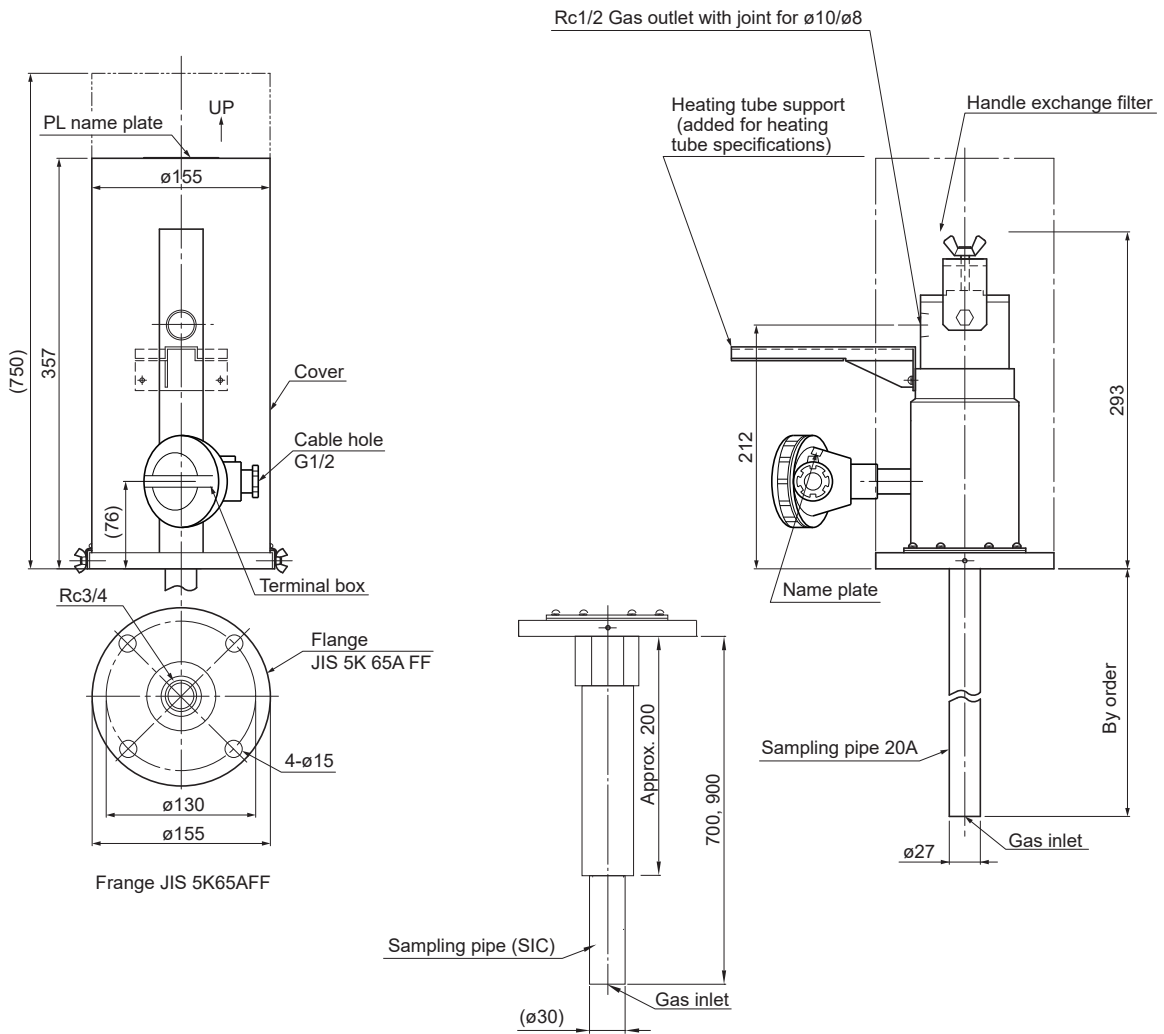

<Drain separator>

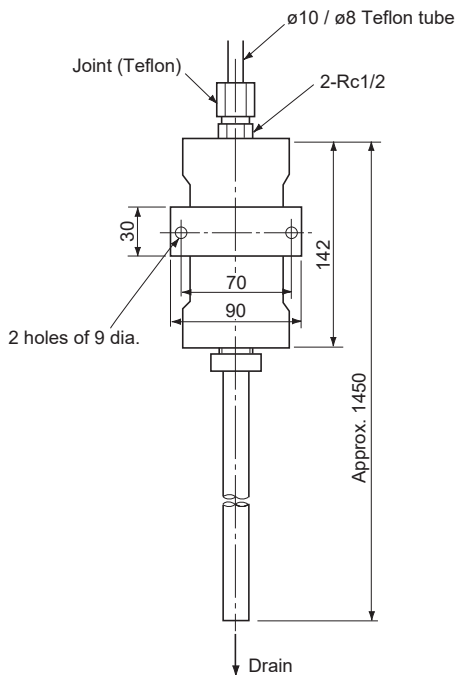

Weight Approx. 0.8 kg

<Drain pot>

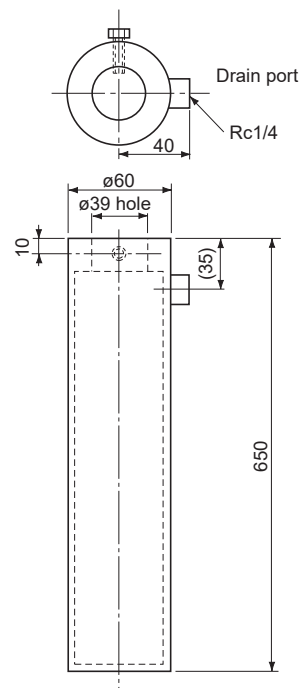

Weight Approx. 0.8 kg

OUTLINE DIAGRAM (Unit: mm)

<Outdoor type>

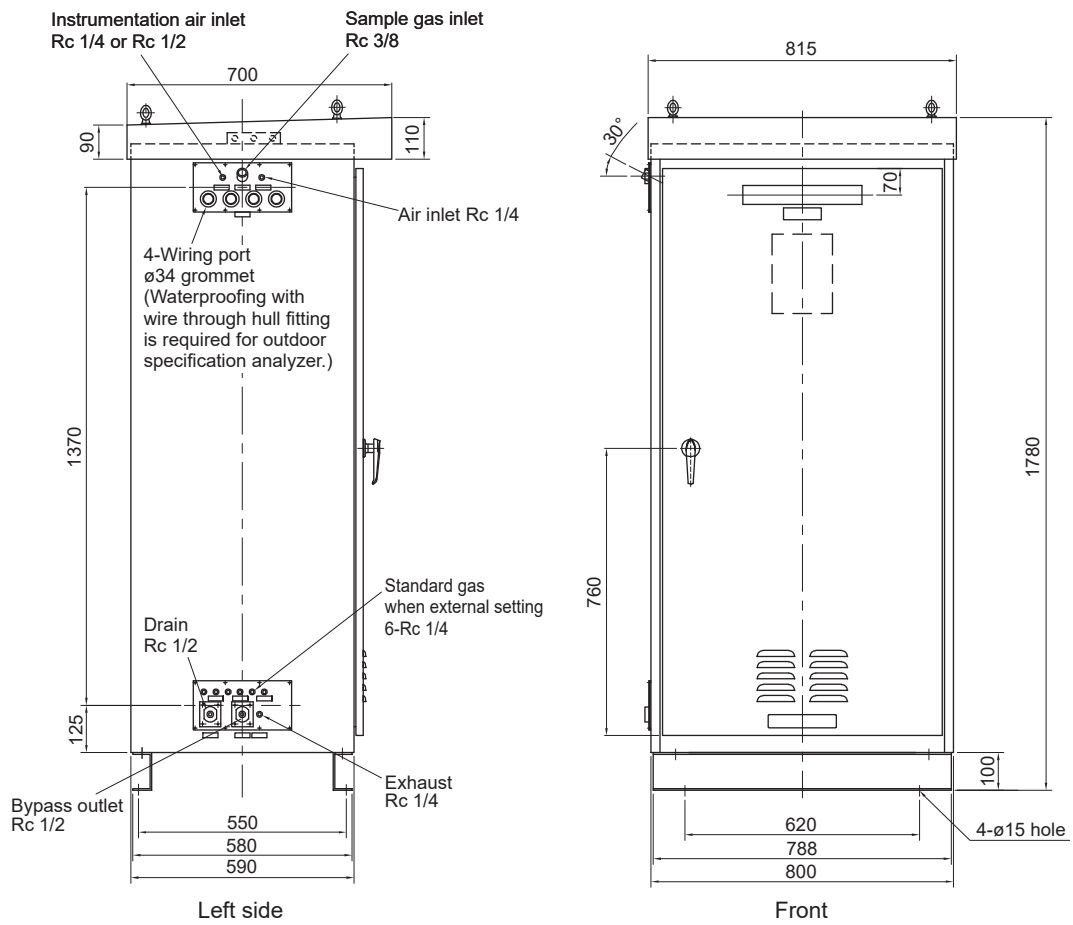

<Indoor type>

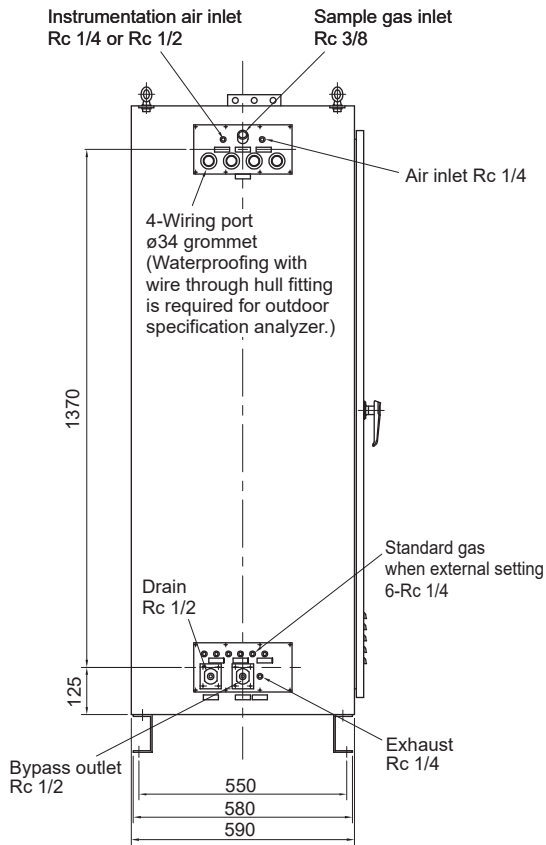

Left side

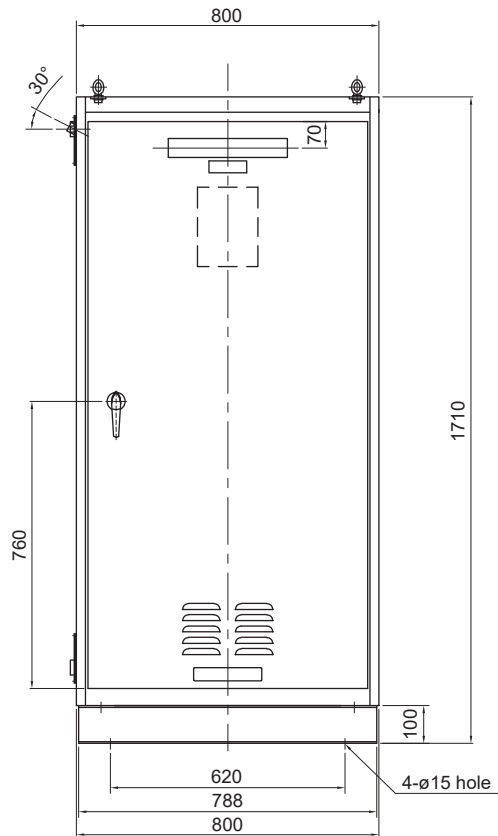

Front

Anchor plan, door open/close diagram

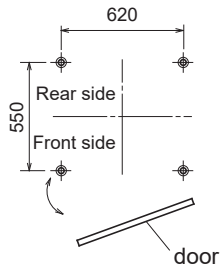

Anchor bolt (option)
(4-M12 × 160 × 50)

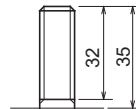

When you contact to Fuji regarding the product, please be sure to inform following specification.

1. Parameter of the measuring gas

Item	Minimum value	Regular value	Maximum value
Measuring gas concentration			
Measuring gas concentration			
Measuring gas concentration			
Measuring gas concentration			
Measuring gas concentration			
Temperature (°C)			
Pressure (Pa)			
Flow velocity (m/s)			
Moisture (vol%)			
Dust (mg/m ³ (N))			
Other component type, Content (vol%/ppm)			
Other component type, Content (vol%/ppm)			
Other component type, Content (vol%/ppm)			

2. Length of the Flue (diameter) _____ mm

3. Distance between gas extractor point and installation place of the unit. _____ m

4. Analog output

	Instantaneous value	O ₂ correction instantaneous value	O ₂ correction average value
NO _x	With / Without	With / Without	With / Without
SO ₂	With / Without	With / Without	With / Without
CO	With / Without	With / Without	With / Without
CO ₂	With / Without		
O ₂	With / Without		

5. O₂ correction value (vol%) _____ vol%

Note: when O₂ correction instantaneous value and/or O₂ correction average value is selected as an analog output at Item 4.

6. Ambient temperature _____ °C _ to _ _____ °C

7. Vibration None/With (_____ G)

8. Items to be prepared separately

- Standard gas and pressure regulator Without / With
- Recorder (Fuji's product type: PHR) Without / With
- Individual inspection of measurement method Without / With
- Spares for 1 year Without / With
- Waterproof gland for outdoor wiring port (A25A) Without / With
- Anchor bolt Without / With

Information in this catalog is subject to change without notice.
Read the instruction manuals thoroughly before using the products.

 **Fuji Electric Co., Ltd.**

Gate City Ohsaki, East Tower, 11-2, Osaki 1-chome, Shinagawa-ku, Tokyo 141-0032, Japan
Phone: +81-3-5435-7111
www.fujielectric.com
www.fujielectric.com/products/instruments/