

# THERMAL CONDUCTIVITY GAS ANALYZER <THERMOMAT>

DATA SHEET

ZAF-6

## OVERVIEW

Thermal conductivity gas analyzer quantitatively measures gas concentration by utilizing a causal relationship that the temperature of a heated platinum wire changes with gas concentration.

The analyzer continuously measures the concentration of gases such as H<sub>2</sub>, He, and Ar with high stability.

## FEATURES

- Easy-to-see LCD
- Linearized output
- Automatic zero and span calibration (option)
- Interference compensation (option)
- RS-232C communication (option)



## SPECIFICATIONS

### Standard Specifications

#### Measuring principle:

Thermal conductivity

#### Measurable component:

He, Ar, H<sub>2</sub>, CH<sub>4</sub>, CO<sub>2</sub>

#### Measurable range:

Refer to Table 1

#### Output signal:

4–20 mA DC, 0–1 V DC, or 0–10 mV DC, isolated output (as specified)

#### Allowable load resistance:

550 Ω max. (in 4 to 20 mA DC output)

#### Output resistance:

100 kΩ (in 0 to 1 V DC or 0 to 10 mV DC output)

#### Display:

LCD with backlight

#### Display of measured value:

Max. 4 digits

#### Display language:

English

#### Output signal holding:

In both manual and automatic calibrations, output value just before calibration can be held.

#### Power supply:

100 to 240 V AC, 50/60 Hz

#### Power consumption:

Approx. 50 VA

#### Warm-up time:

At least 30 min

#### Ambient temperature:

–5 to 45°C

#### Ambient humidity:

≤ 90% RH (condensation unallowable)

#### Storage conditions:

–20 to 60°C, ≤ 95% RH (condensation unallowable)

#### Mounting:

Flush mounting on panel

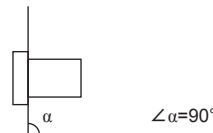

#### Dimensions (H × W × D):

240 × 192 × 213 mm

#### Mass:

Approx. 5 kg

#### Finish color:

Off-white (equivalent to 10Y7.5/0.5)

#### Housing:

Steel-plate case, indoor use type

#### Material of gas-contacting parts:

JIS SUS304, platinum, platinum iridium, silver, fluororubber, epoxy resin, nickel, tin

#### Gas inlet/outlet, purge port:

Rc1/4 or NPT1/4 (whichever specified)

#### External connection terminal:

M3.5 screw terminal (9-pin D-sub connector for RS-232C)

#### Purge gas flow rate:

Approx. 1 L/min (for measurement of combustible gases)

**Performance****Repeatability:**

±1% of FS

**Linearity:**

±2% of FS

**Drift:**Zero point: within ± 2% of FS/week (H<sub>2</sub> meter, reference gas N<sub>2</sub>)Span: within ± 2% of FS/week (H<sub>2</sub> meter, reference gas N<sub>2</sub>)**Response time (90% response):**High speed: within 10 s (at flow rate 1L/min), allowed only for H<sub>2</sub> meter (reference gas N<sub>2</sub>, without interference compensation)

Standard: within 60 s (at flow rate 0.4 L/min)

**Interference:**

Indication error of each measured value (vol%)

Interference component	H <sub>2</sub> meter	CH <sub>4</sub> meter	Ar meter	CO <sub>2</sub> meter
H <sub>2</sub> 1%	–	+5.8	–6.5	–8.0
CH <sub>4</sub> 1%	+0.17	–	–1.15	–1.38
SO <sub>2</sub> 1%	–0.31	–1.8	+2.1	+2.5
Ar 1%	–0.15	–0.87	–	+1.2
CO <sub>2</sub> 1%	–0.125	–0.725	+0.83	–
O <sub>2</sub> 1%	+0.019	+0.11	–0.125	–0.15
H <sub>2</sub> O 1.5°C saturation	–	–	–	–0.56
CO 1%	–0.015	–	–	–

**Standard Gas Measurement Conditions****Temperature:**

0 to 50°C

**Gas flow rate:**

Constant at 0.4 ± 0.05 L/min

Constant at 1 ± 0.05 L/min (High-speed response type)

**Dust:**Less than 100 µg/Nm<sup>3</sup> with a particle size of 0.3 µm max**Pressure:**

10 kPa max

**Mist:**

Unallowable

**Oxygen gas:**No oxygen should be contained in measured combustible gases. (O<sub>2</sub> must not exist in the sample gas for the H<sub>2</sub> gas analyzer)**Moisture:**

Below saturation at 2°C

**Corrosive gas:**

Unallowable

**Standard gases for calibration:**

Zero gas: same as reference gas or as specified

Span gas: Concentration between 90 and 100% of measuring range (Positive range)

Concentration beyond 100% is unallowable

**Installation Conditions**

- The analyzer should not be exposed to direct sunlight or radiation from a hot object.
- A place subjected to heavy vibrations should be avoided. A location with clean atmosphere should be selected.
- Before measuring combustible gases, the existing gases should be purged from the analyzer using air or N<sub>2</sub>.
- When the analyzer is installed outdoors, it should be sheltered with a housing or cover to protect it from rain and wind.

**Optional Specifications****Relay contact output:**

5 SPST-NO relay contact outputs

Relay contact capacity; 220 V AC/2 A (resistive load)

Isolated with relay between contacts, and between contacts and internal circuit.

Max. 5 points are selectable among those listed below.

- <1> Zero-side solenoid valve drive output for automatic calibration
- <2> Span-side solenoid valve drive output for automatic calibration
- <3> Suction pump OFF output in automatic calibration (relay "ON" immediately after turning on power supply)
- <4> Upper limit (1 point) concentration alarm output
- <5> Lower limit (1 point) concentration alarm output
- <6> Upper/Lower limit (1 point) concentration alarm output
- <7> Upper limit (1 point) and lower limit (1 point) concentration alarm output (Total 2 points)
- <8> High-high limit (1 point at each step) concentration alarm output (Total 2 points)
- <9> Low-low limit (1 point at each step) concentration alarm output (Total 2 points)
- <10> Analyzer error or automatic calibration error alarm output
- <11> Calibrating status output
- <12> Range information output (only with 2-range meter)

**Contact input:**

3 non-voltage contact inputs

ON; 0 V, OFF; 5 V DC, current at ON; 5 mA

Isolated with photo coupler between inputs and internal circuit. Not isolated between contact inputs.

The following actions can be selected:

- <1> Remote holding of measured value output
- <2> Remote range changeover (only with 2-range meter)
- <3> Remote start of automatic calibration

**Interference gas measured value input:**Analog input for H<sub>2</sub> meter interference correction (1 to 5 V DC, 1 range)Either CO<sub>2</sub> or CH<sub>4</sub> measured by an external gas analyzer. Adjustment is required at Fuji Electric's factory.

Details of measurement gas will be checked when receiving an order.

**Automatic calibration:**

Zero and span calibrations are automatically carried out at the predetermined intervals.

Calibration gases are flowed sequentially by driving the externally installed solenoid valves.

**Communication:**

RS-232C (9-pin D-sub output)

Half duplex, asynchronous

MODBUS™ protocol, communication speed 9600 bps

Contents of communication:

Reading/writing of measured concentration values and various set values, and output of device status

To connect with a device with RS-485 interface, use an RS232–RS485 converter.

**EU Directive Compliance** 

**LVD (2014/35/EU)**

EN 61010-1  
EN 62311

**EMC (2014/30/EU)**

EN 61326-1 (Table 2)  
EN 55011 (Group 1 Class A)  
EN 61000-3-2 (Class A)  
EN 61000-3-3  
EN 61326-2-3

**RoHS (2011/65/EU)+(EU)2015/863**

EN IEC 63000

**Explanation of Functions**

Output signal holding	When holding is set (user setting is turned ON), the latest measured value output just before output signal holding will be held during manual or automatic calibration, or by remote output holding input. In this status, indicated values will not be held.
Remote output holding input	Upon short-circuiting the remote output holding input terminal when holding is set (user setting is turned ON), the latest measured value output will be held. Holding continues while the contact input terminal is close-circuited. In this period, indicated values will not be held.
Remote range changeover input	When remote range setting is selected (user setting is turned ON) for two rang type, range will be changed over according to the external signal input (non-voltage contact) applied to the remote range changeover input terminal. In this mode, range cannot be changed manually. When close-circuiting the contact input terminal, the first range is selected, and the second range is selected at open circuit.
Range identification signal output	With two rang type, the current measuring range identification is output in contact signal. The contact output terminal is closed for the first range, and open for the second range.
Automatic calibration	Zero and span calibrations are automatically carried out by outputting the signal for driving the externally installed solenoid valves for calibration gases at the set start time and interval or through input of the remote calibration start signal. <ul style="list-style-type: none"> <li>• Calibration channel: 1 component</li> <li>• Calibration accuracy: 0.2% of F.S.</li> <li>• Zero calibration point settable range: 0 to 100% of F.S.</li> <li>• Span calibration point settable range: 1 to 100% of F.S.</li> <li>• Calibration interval settable range: 1 to 99 hours (1 hour step) or 1 to 40 days (1 day step)</li> <li>• Calibration gas injection time settable range: 60 to 599 sec (in sec)</li> <li>• Calibration start: Internal timer or remote calibration start input</li> <li>• Solenoid valve drive signal output: SPST contact (zero x 1, span x 1)</li> <li>• Suction pump OFF output in calibration: SPST contact (suction pump OFF x 1)</li> <li>• Remote calibration start input: No-voltage contact input Automatic calibration is started by applying a non-voltage rectangular wave to the remote calibration start input terminal (opened after close-circuiting for 1.5 sec or longer). When contacts open, automatic calibration is carried out once.</li> <li>• Automatic calibration error alarm output: SPST contact Contacts close when the quantity of zero or span calibration exceeds 50% of full scale from the level of previous calibration, and contacts open when there is no abnormalities. When automatic calibration is abnormal, measurement output depends on the previous calibration values.</li> <li>• Automatic calibration status output: SPST contact During automatic calibration, contacts close, and open when within 50%.</li> </ul>
Upper/lower limit, upper limit and lower limit alarm output	Alarm contact output is issued with reference to the set upper/lower limit for alarm. Hysteresis is settable. When measuring value exceed alarm setting value, contacts close, and open when not exceeded. SPST contact
Analyzer error	When the analyzer or automatic calibration is abnormal, contacts close, and open when normal. SPST contact
Interference compensation by interference gas measured value input	Correction is made using either CO <sub>2</sub> or CH <sub>4</sub> component for H <sub>2</sub> measurement. Measured H <sub>2</sub> gas concentration is corrected in response to a concentration change of interference gas within its concentration range measured and set in advance. External interference gas measured value input : 1 to 5 V DC, 1range Interference gas fluctuation range : Reference concentration 20% F.S. H <sub>2</sub> gas concentration correcting range : Reference concentration 25% F.S. Correction accuracy : 5% F.S. (Note 1) Enter in the sample gas component check list on the back cover. (Note 2) Correction accuracy value is larger when other interference gas is contained in the sample gas.

### MEASURING PRINCIPLE

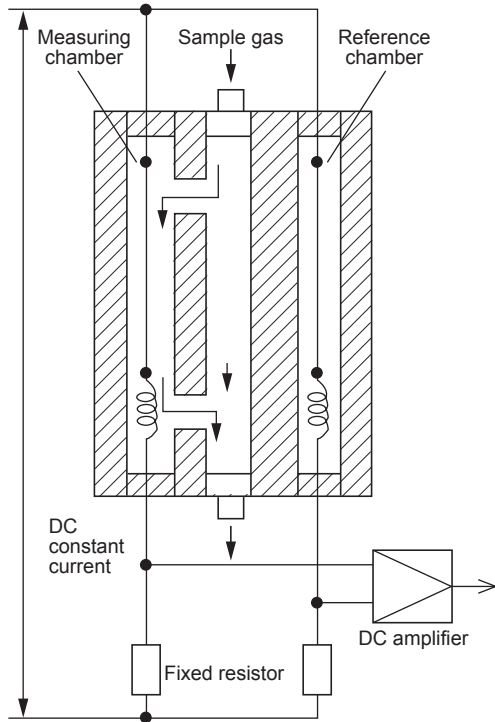

This thermal conductivity gas analyzer measures gas concentration by utilizing the different thermal conductivities of 2 gas components. In the detector, there are reference and measuring chambers in each of which a thin platinum wire is stretched. The reference chamber is filled with reference gas and through the measuring chamber, sample gas is flowed. Each platinum wire composes a bridge circuit in combination with an external fixed resistor, and it is heated by flowing a constant current. When there is a change in the concentration of the component under measurement, the thermal conductivity of sample gas will change to affect the temperature of the platinum wire in the measuring chamber. The resulting thermal change is taken out as a change in electric resistance, according to which the concentration of measured gas is calculated.

### Thermal Conductivity of Gases

Gases		Thermal conductivity at 0°C in reference to thermal conductivity of air, $2.41 \times 10^{-2} \text{ W/(m}\cdot\text{K)}$
Sulfur dioxide	SO <sub>2</sub>	~0.15
Carbon dioxide	CO <sub>2</sub>	~0.20
Argon	Ar	~0.25
Carbon monoxide	CO	~0.30
Steam (100C)	H <sub>2</sub> O	~0.35
Air		1.00
Nitrogen	N <sub>2</sub>	~0.40
Oxygen	O <sub>2</sub>	~0.45
Methane	CH <sub>4</sub>	~0.50
Hydrogen	H <sub>2</sub>	~0.60

Table 1: Measurable Component and Measurable Range

Measured gas	Reference gas (Note 1)	Measurable range	Maximum rangeability
H <sub>2</sub>	N <sub>2</sub> , (CO <sub>2</sub> , Ar, He)	0 to 3, 5, 10, 20, 50, 80, 100% 100 to 90, 100 to 80%	1 : 10
He	N <sub>2</sub> , (CO <sub>2</sub> , Ar) O <sub>2</sub> , Air	0 to 5, 10, 20, 30, 40, 50, 80, 100% 100 to 90, 100 to 80%	1 : 10
Ar	N <sub>2</sub> , O <sub>2</sub> , Air, (He)	0 to 10, 20, 50, 80, 100% 100 to 90, 100 to 80%	1 : 5
CH <sub>4</sub>	N <sub>2</sub> , (CO <sub>2</sub> , Ar, He)	0 to 20, 40, 50, 60, 80, 100% 100 to 80%	1 : 5
CO <sub>2</sub>	N <sub>2</sub> , O <sub>2</sub> , Air, (He)	0 to 10, 20, 50, 100% 100 to 90, 80%	1 : 5

(Note 1) Consult us for the components in the parentheses. H<sub>2</sub> contained in O<sub>2</sub> cannot be measured.

### GAS SAMPLING SYSTEM DIAGRAM (EXAMPLE)

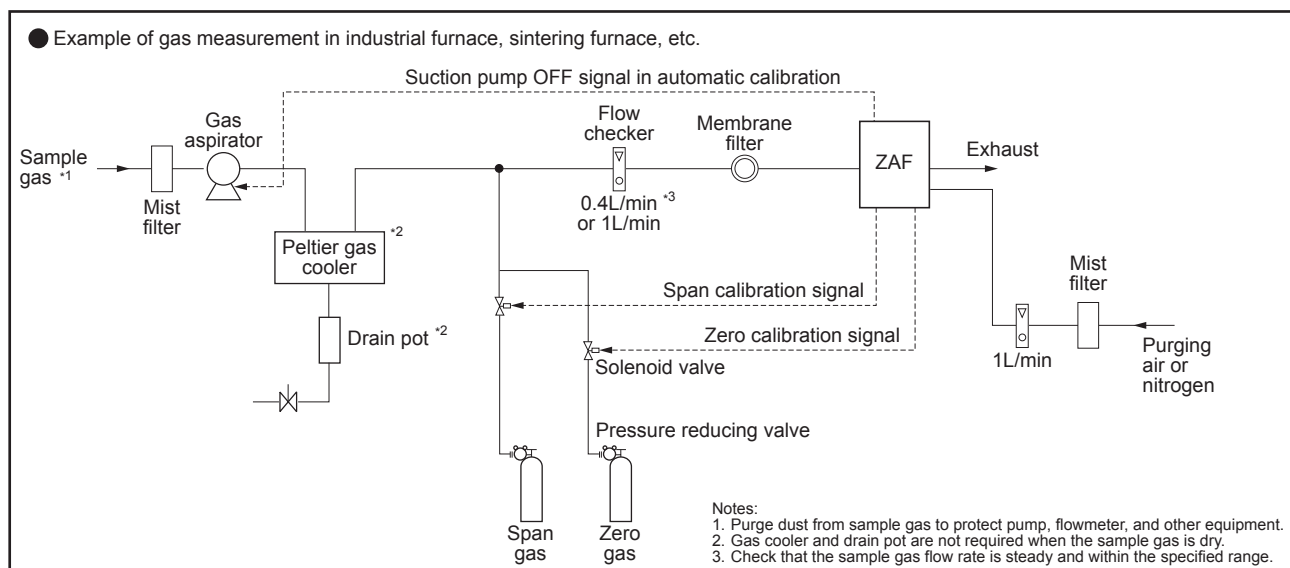

# CODE SYMBOLS

Digit	Description	ZAF	4	5	6	7	8	9	10	11	12	13	14	15	16	17	18
4	<Specification> Standard		4														
5	<Measured component> (Note 6) H <sub>2</sub> Ar He CH <sub>4</sub> CO <sub>2</sub> (reference gas Ar unallowable) Other		K	L	M	E	A										
6	<Reference gas> (Note 1) N <sub>2</sub> Air (incompatible with H <sub>2</sub> /CH <sub>4</sub> measurement) O <sub>2</sub> (incompatible with H <sub>2</sub> /CH <sub>4</sub> measurement) Ar Other		4	5	6	7	Z										
7	<Connection port size> Rc1/4 NPT1/4				0	1											
8	<Revision No.>				6												
9	<Measuring range (1st range)> 0 to 3% (H <sub>2</sub> ) 0 to 5% (H <sub>2</sub> , He) 0 to 20% (H <sub>2</sub> , He, Ar, CO <sub>2</sub> ) ----- 0 to 30% 0 to 50% 0 to 80% 0 to 100% 100 to 90% (H <sub>2</sub> , He, Ar) 100 to 80% (H <sub>2</sub> , He, Ar, CH <sub>4</sub> ) Other							Q	L	M	N	V					
10	<Measuring range (2nd range)>(Note 2) None 0 to 5% (H <sub>2</sub> , He) 0 to 10% (H <sub>2</sub> , He, Ar) 0 to 20% (H <sub>2</sub> , He, Ar, CO <sub>2</sub> ) ----- 0 to 30% 0 to 50% 0 to 80% 0 to 100% Other							Y	L	M	N	V					
11	<Measured value output> 4 to 20 mA DC 0 to 1V DC 4 to 20 mA DC + RS-232C communication 0 to 1 V DC + RS-232C communication 0 to 10mV DC								A	B	C	D	E				
12	— (Note 5)																
13	<H <sub>2</sub> meter interference compensation> (Note 3) None Provided									Y	A						
14	<Input/output contacts> None Automatic calibration Concentration alarm Contact output selection } See table below.												Y	A	C	E	
15	<Indication> Japanese English														J	E	
16	<Response speed> Standard response High-speed response (Note 4)															A	B
17	—																Y
18	—																Y

## Notes:

- The reference gas must be of different kind from the gas to be measured. Select a gas by reference to Table 1. If you use the external CO<sub>2</sub> analyzer or CH<sub>4</sub> analyzer for interference compensation (13th code "A"), select "Z" in the 5th code.
- The ratio of maximum range to the first range is as given below.  
For CO<sub>2</sub>, Ar or CH<sub>4</sub> measurement : 1st range × 5 (times)  
For He or H<sub>2</sub> measurement: 1st range × 10 (times)  
1st range < 2nd range  
You cannot combine a reverse range (100 to ...%) with a normal range (0 to ...%).  
If you select a reverse range in the 1st range, the 2nd range shall be "None" (10th code "Y").
- A CO<sub>2</sub> or CH<sub>4</sub> meter needs to be prepared separately.  
Input signal is 1 to 5 V DC.  
Adjustment is required at Fuji Electric's factory.  
Details of measurement gas will be checked when receiving an order.  
Unavailable when you selected a reverse range (100 to ...%).  
Unavailable when you selected the high-speed response option (the 16th code "B").

## <Supported interference compensation range>

The interference compensation of the H<sub>2</sub> analyzer (CO<sub>2</sub>, CH<sub>4</sub>) can be adjusted up to the upper limit of the interference gas concentration listed in the table below. Please note that compensation beyond the upper limit is not possible.

Upper limit of interference gas concentration for H<sub>2</sub> analyzer interference compensation

H <sub>2</sub>	Interference value per 1 vol.% of interference gas	
	-0.125vol.%	-0.725vol.%
Range	CO <sub>2</sub>	CH <sub>4</sub>
0-3%	≤ 24vol.%	≤ 4vol.%
0-5%	≤ 40vol.%	≤ 5vol.%
0-10%	≤ 80vol.%	≤ 10vol.%
0-20%	≤ 100vol.%	≤ 20vol.%
0-30%	≤ 100vol.%	≤ 40vol.%
0-50%	≤ 100vol.%	≤ 60vol.%
0-80%	≤ 100vol.%	≤ 100vol.%
0-90%	≤ 100vol.%	≤ 100vol.%
0-100%	≤ 100vol.%	≤ 100vol.%

- High-speed response is available only for the H<sub>2</sub> measurement (5th code "K") with the reference gas N<sub>2</sub> (6th code "4").
- If you want to use the non-linear output, enter "Y" in the 12th code.
- If O<sub>2</sub> is contained in the sample gas for the H<sub>2</sub> gas analyzer, it will cause an explosion. Thus, measurement is not allowed. If the O<sub>2</sub> concentration is lower than the explosion limit, it will cause indication errors, which precludes the measurement.

Input/output contact specifications		14th digit : A	14th digit : C	14th digit : E
		Automatic calibration	Concentration alarm	Contact output selection (Note 7)
Contact output	Automatic calibration Span gasvalve drive Suction pump OFF in automatic calibration	○ (DO1) ○ (DO2) ● (DO3)	— — —	○ ○ ●
	Concentration alarm Upper limit (1 point) Lower limit (1 point) Upper/lower limit (1 point as a set) Upper limit (1 point) and lower limit (1 point) 2-step upper limit (1 point each) 2-step lower limit (1 point each)	— — — — — —	Any one alarm settable on screen (DO1, 2)	Any one alarm settable on screen
	Other Calibration status Range information (2-range meter) (Note 3) Analyzer error or automatic calibration error	○ (DO4) — ○ (DO5)	○ (DO4) ○ (DO3) ○ (DO5)	○ ○ ○
Contact input	Remote automatic calibration start (Note 4) Remote range changeover (2-range meter) (Note 5) Remote measured value output holding (Note 6)	○ (DI3) ○ (DI2) ○ (DI1)	○ (DI3) ○ (DI2) ○ (DI1)	○ (DI3) ○ (DI2) ○ (DI1)

## Notes:

- Mark ○: Normally Open (NO) contact
- Mark ●: When the power is supplied, the contact is kept closed.
- Low range : Contacts close, High range : Contacts open

- When you close the contact for 1.5 seconds and then open it, the automatic calibration starts.
- Contact closed : Low range, Contact open : High range
- Contact closed : Holding, Contact open : Holding canceled
- Up to 5 contact output points can be selected.

OUTLINE DIAGRAM (Unit : mm)

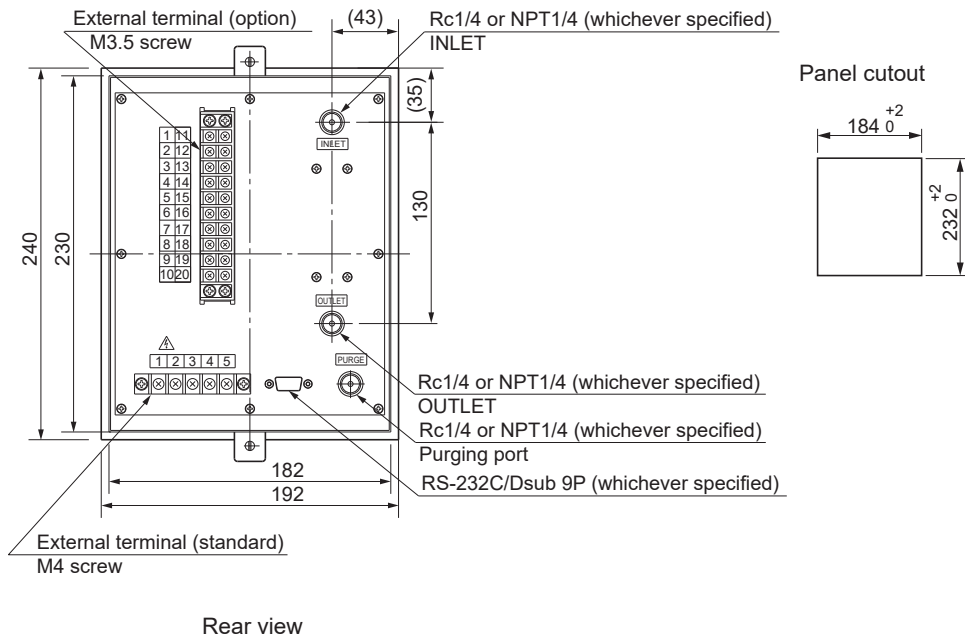
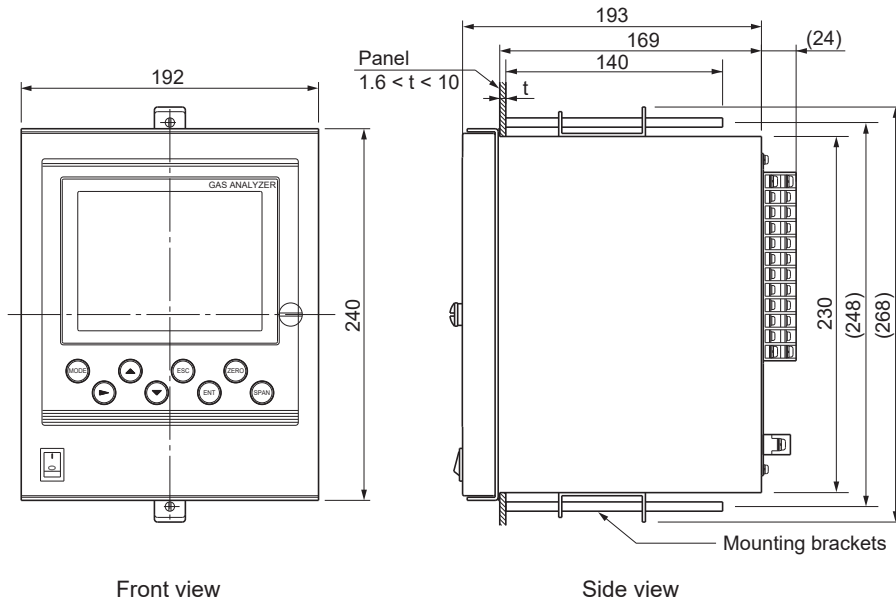

CONNECTION DIAGRAM

(Standard)

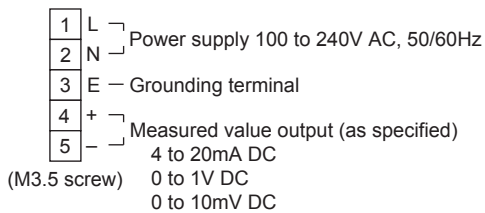

(Option) 13th digit A and 14th digit A, C, E,

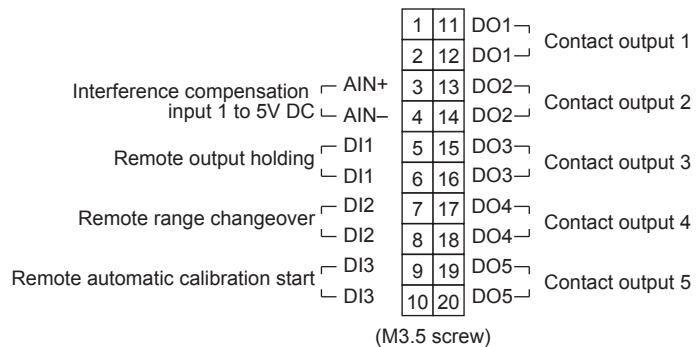

Refer to "Input/output contact specifications" in the previous page.

## SCOPE OF DELIVERY

Analyzer  
Panel mounting brackets (1 set)  
2 power fuses (250 V AC, 1 A)  
Instruction manual

## ITEMS TO BE PREPARED SEPARATELY

Gas sampling equipment, standard gas, receiving instrument, etc.

CH<sub>4</sub> or CO<sub>2</sub> analyzer if you need the interference compensation for H<sub>2</sub> measurement.

## ORDERING INFORMATION

1. Code symbols
2. Gas component to be measured
3. Measuring range
4. Gas component other than measured  
Very important information required to achieve intended accuracy of the instrument.  
(Fill in "Table for checking sample gas component" on the next page.)

## <Table for checking sample gas component of thermal conductivity gas analyzer (ZAF)>

Let us check your sample gas for safe use of Fuji Electric' gas analyzer.

Make entries where you can answer. If there is any question, contact our salesperson in charge of your company.

The analyzer may not provide full performance depending on other gas components contained in sample gas.

Date

Item	Description
Enduser name	
Application, purpose	
Gas component to be measured	

Sample gas	Minimum concentration (%)	Normal concentration (%)	Maximum concentration (%)	Remarks
Component to be measured				
Other component gas				
Other component gas				

Interference gas input	Measuring range	CO <sub>2</sub> meter or CH <sub>4</sub> meter
	0-	

Your question, etc.	
---------------------	--

Customer information	Company name
	Section
	Address
	TEL
	Person in charge

Fuji Electric's salesperson in charge of your company \_\_\_\_\_

Information in this catalog is subject to change without notice.  
Read the instruction manuals thoroughly before using the products.

 **Fuji Electric Co., Ltd.**

Gate City Ohsaki, East Tower, 11-2, Osaki 1-chome, Shinagawa-ku, Tokyo 141-0032, Japan  
Phone: +81-3-5435-7111  
www.fujielectric.com  
www.fujielectric.com/products/instruments/