

BIOMASS GAS ANALYZER

DATA SHEET

ZPAF

This gas analyzer (ZPAF) can simultaneously measure the concentration of CH₄, CO₂, H₂S and O₂ components in sample gas. CO₂ and CH₄ are measured by non-dispersion infrared method (NDIR), O₂ is measured by fuel cell, and H₂S is measured by constant-potential electrolytic method. ZPAF provides high-stability and ease-of-maintenance incorporated into a space-saving design. All these features make ZPAF ideal for biogas plants.

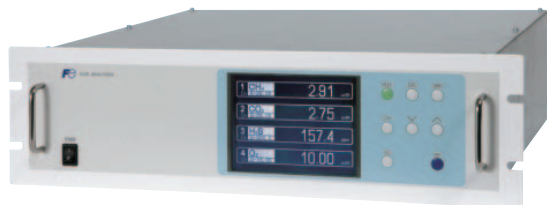

FEATURES

- 1. Compact and lightweight**
133 (H) × 483 (W) × 382 (D) mm, 9 kg
- 2. Easy maintenance**
Thanks to the use of single-beam system, optical adjustment is not required.
- 3. User-friendly operation**
Clear and easy-to-read display facilitates operation.
- 4. Extensive functions**
Various optional functions are available such as auto calibration control, high and low concentration alarms, remote range switch, and range identification signal, etc.

SPECIFICATIONS

Standard Specifications

Principle of measurement:

- CH₄, CO₂ ;
Non-dispersion infrared-ray absorption method
Single light source and single beams (single beam system)
- O₂ ; Fuel cell O₂ analyzer
- H₂S ; Constant-potential electrolytic method

Measurable gas components and measuring range:

	1st range	2nd range
CH ₄	0 - 20 vol%	0 - 100 vol%
CO ₂	0 - 20 vol%	0 - 100 vol%
H ₂ S	0 - 500 ppm	0 - 2000 ppm 0 - 5000 ppm
O ₂ (Built in fuel cell)	0 - 10 vol%	0 - 25 vol%

- Max. 4 components including O₂.
- Two measurement ranges are provided for each component, and a user can switch between them.

Measured value indication:

- Digital indication in 4 digits (LCD panel with LED back light)
- Instantaneous value of each component

Analog output signals:

4 to 20mA DC or 0 to 1V DC, isolated internally from circuit and ground. Output lines are non-isolated each other.; 12 outputs max.
Allowable load 550Ω for 4 to 20mA DC
Allowable load 100KΩ for 0 to 1V DC

Digital output: (Option)

1c contact (24V DC/1A, resistive load) max.15 outputs
Instrument error, calibration error, range identification, auto calibration status, solenoid valve drive for auto calibration, High/Low limit alarm contact output.

* All relay contacts are isolated mutually and from the internal circuit.

Digital input: (Option)

Voltage contact (supply 12-24V DC (15mA Max.)) Max. 9 inputs
Remote range change over, auto calibration remote start, remote hold, Isolated from the internal circuit with photocoupler.

Power supply: Voltage rating ; 100V to 240V AC
Allowable range ; 85V to 264V AC
Frequency ; 50Hz/60Hz
Power consumption ; 100VA max.

Ambient temperature:

5°C to 40°C (CH₄, CO, and 0-2000 ppm H₂S analyzers)
15°C to 40°C (other than the above)

Ambient humidity:

90% RH max., no condensation

Storage conditions:

Ambient temperature ; -20°C to 50°C
Ambient humidity ; 90% RH max., non-condensing

Dimensions (H × W × D):

133 × 483 × 382mm

Mass:

Approx. 9 kg max.

Finish color:

Front panel; Cool gray (PANTON 1C-F)

Enclosure: Steel casing, for indoor use
Material of gas-contacting parts:
 Gas inlet/outlet; SUS304
 Sample cell; SUS304, chloroprene rubber
 Infrared-ray transmitting window; CaF2
 Internal piping; Toaron, Teflon, Polypropylene
 Solenoid valve: SUS316, fluororubber
 Fuel cell O₂ analyzer cell : ABS resin
Gas inlet/outlet: Rc1/4 or NPT1/4 internal thread
Analyzer purge gas flow rate: 1L/min (Analyzer purge with N₂ or air is indispensable)
Life time of fuel cell O₂ analyzer: 2 years
Life time of constant-potential electrolytic H₂S sensor:
 1 year (under an average ambient temperature of 35°C)

Standard Functions

Output signal holding:
 Output signals are held unchanged during manual and auto calibrations by activation of holding (turning "ON" its setting). The values held are those just before start calibration mode or setting value. Usage is selectable. Indication of instantaneous values will not be held.

Switch ranges: The switch ranges function is available in manual, auto, and remote modes. Only preset switch method is effective.

Manual: Allows range to switch by key operation.
Auto: Automatically switched from first range to second range when the measured value exceeds 90%FS of first range. Automatically switched from second range to first range when the measured value drops to 80% or less first range.

Remote: Voltage contact input (Option)
 Allows range to switch via an external signal when remote range switch input is received. When the contact input terminals for each component are input voltage, the first range is selected, and it is switched to the second range when the terminals are open.

* These switch range value are settable between the first range and second range values (low/high range values).

Optional Functions

Remote output holding:
 Output signal is held at the last value or preset value by voltage input to the remote output holding input terminals. Holding is maintained while the voltage is input to the terminals. Indication of instantaneous values are not held.

Range identification signal:
 The present measuring range is identified by a contact position. The contact output terminals close for each component when the first range is selected, and open when the second range is selected.

Auto calibration:
 Auto calibration is carried out periodically at the preset cycle. When a standard gas cylinder for calibration and a solenoid valve for opening/closing the gas flow line are prepared externally by the customer, calibration will be carried out with the solenoid valve drive contacts for zero calibration and each span calibration turned on/off sequentially at the set auto calibration timing.

Auto calibration cycle setting:
 Auto calibration cycle is set. Setting is variable within 1 to 99 hours (in increments of 1 hour) or 1 to 40 days (in increments of 1 day).

Gas flow time setting:
 The time for flowing each calibration gas in auto calibration is set. Settable within 60 to 900 seconds (in increments of 1 second)

Auto calibration remote start:
 Auto calibration starts by opening the auto calibration remote start input terminal after short circuiting for 1.5 sec or longer. Auto calibration starts when contacts open.

Auto zero calibration:
 Auto zero calibration is carried out periodically at the preset cycle. This cycle is independent from "Auto calibration" cycle. When zero calibration gas and solenoid valve for opening/closing the calibration gas flow line are prepared externally by the customer, zero calibration will be carried out at the set auto zero calibration timing.

Auto zero calibration cycle setting:
 Auto zero calibration cycle is set. Setting is variable within 1 to 99 hours (in increments of 1 hour) or 1 to 40 days (in increments of 1 day)

Gas flow time setting:
 The timing for flowing zero gas in auto zero calibration is set. Settable within 60 to 900 seconds (in increments of 1 second)

High/low limit alarm:
 Alarm contact output turns on when measurement value reaches the preset high or low limit alarm value. Contacts close when the instantaneous value of each channel exceeds the high alarm limit value or falls below the low alarm limit value.

Instrument error contact output:
 Contacts turn on at occurrence of analyzer error No. 1, 2, 3 or 10.

Calibration error contact output:
 Contacts turn on at occurrence of manual or auto calibration error (any of errors No. 4 to 9).

Auto calibration status contact outputs:
 Contacts turn on during auto calibration.

Communication function:

RS-485 (9pins D-sub connector)
 Half-duplex bit serial
 Start-stop synchronization
 Modbus RTU™ protocol
 Contents : Read/Write parameters
 Read measurement concentration and instrument status
 Remark : When connecting via RS-232C interface, an RS-232C ↔ RS-485 converter should be used.

Performance

Repeatability: ±0.5% of full scale (H₂S: ±2.0 %FS)
Linearity: ±1% of full scale (H₂S: ±2.0 %FS)
Zero drift: ±2% of full scale/week
Span drift: ±2% of full scale/week
 *H₂S analyzer (0-2000 ppm range): ±2.5 % of FS/week
 *H₂S analyzer (0-5000 ppm range): ±5 % of FS/day
Response time (for 90% FS response) :
 1 to 15 sec electrical response. Within 10-30 seconds including replacement time of sampling gas.
 *H₂S analyzer (0-2000 ppm range): within 180 s
 *H₂S analyzer (0-5000 ppm range): within 300 s

EU Directive Compliance 

LVD (2014/35/EU)
 EN 61010-1
 EN 62311
 EMC (2014/30/EU)
 EN 61326-1(Table 2)
 EN 55011(Group 1 Class A)
 EN 61000-3-2(Class A)
 EN 61000-3-3
 EN61326-2-3
 RoHS (2011/65/EU)
 EN 50581

Requirements for Sample Gas

Flow rate: 0.5 ±0.2L / min (including purge gas for H₂S measurement)
Temperature: 10 to 50°C
Pressure: 10 kPa or less (Gas outlet side should be open to the atmospheric air.)
Dust: 100 µg/Nm³ or less in particle size of 0.3 µm or smaller
Mist: Unallowable
Moisture: Less than the content saturated at 2°C
Corrosive component: 1 ppm or less
 (H₂S scrubber is required on pipings for NDIR and O₂ measurement.)

Standard gas for calibration:

1) Infrared-ray measurable component, standard O₂
 Zero gas ; Dry air
 Span gas ; Each sample gas having concentration 90 to 100% of its measuring range (recommended).
 2) H₂S measurement
 Zero gas: air *
 Span gas: concentration of 90 to 100 % of its measuring range
 Purge gas: air *
 *Use moist air saturated at the temperature from 2°C through room temperature. Do not use air which includes H₂S nor dry air saturated below 2°C.

Installation Requirements

- Indoor use (Select a place where the equipment does not receive direct sunlight, draft/rain or radiation from hot substances. If such a place cannot be found, a roof or cover should be prepared for protection.)
- Avoid a place where unit receives heavy vibration
- Select a place where atmospheric air is clean
- Analyzer purge with N₂ or air is indispensable.
- Handle H₂S with great care as it is toxic, flammable, and corrosive.
- For safety, install an H₂S alarm around the analyzer.

Items to be Prepared Separately

- Constant-potential electrolytic H₂S sensor (for replacement): TQ503691C1 (for 0-2000 ppm range) TQ503691C3 (for 0-5000 ppm range)
- Galvanic O₂ sensor (for replacement): TQ503691C2

Principle diagram of constant-potential electrolytic measurement (For H₂S)

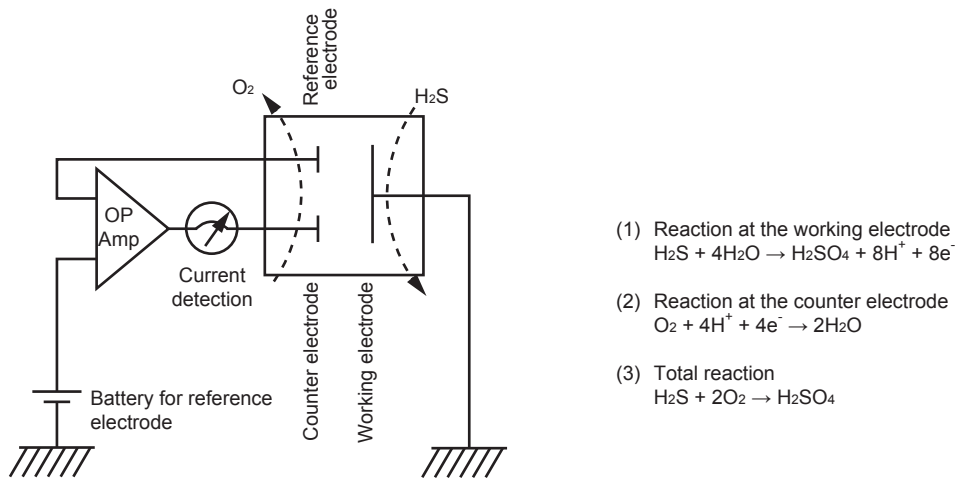

Principle diagram of H₂S measurement

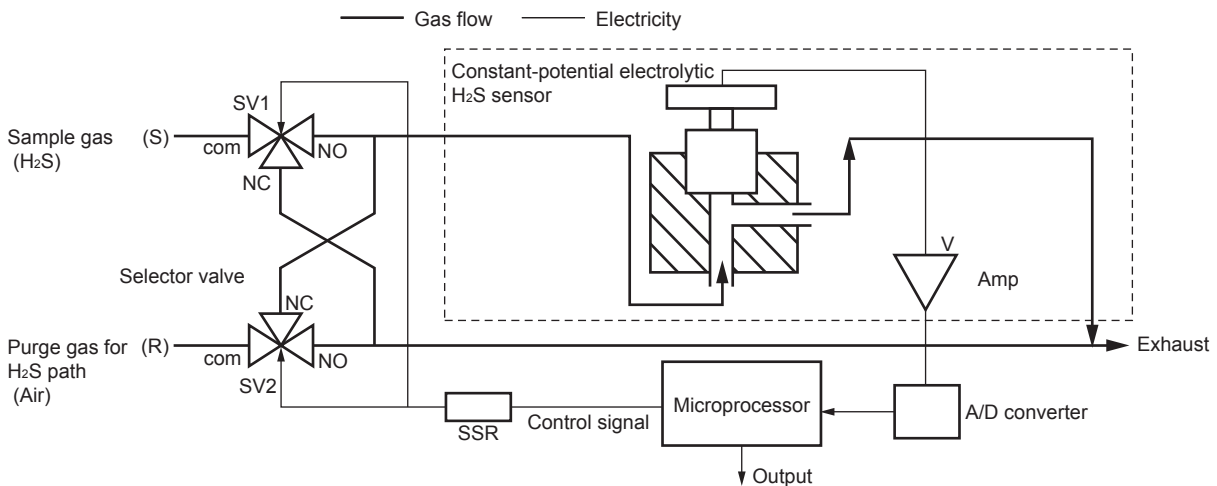

Principle diagram of NDIR type measurement (For CO₂, CH₄)

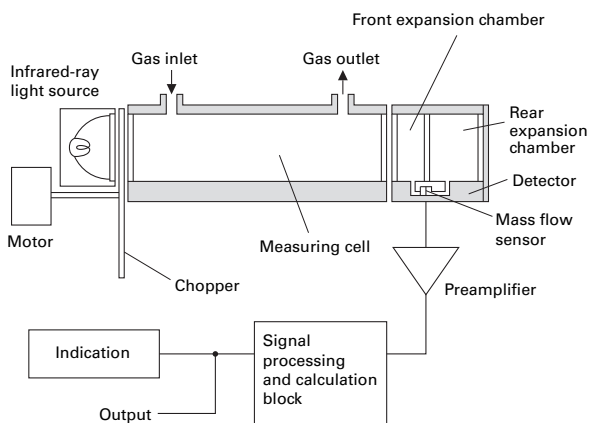

Principle diagram of fuel cell type measurement (For O₂)

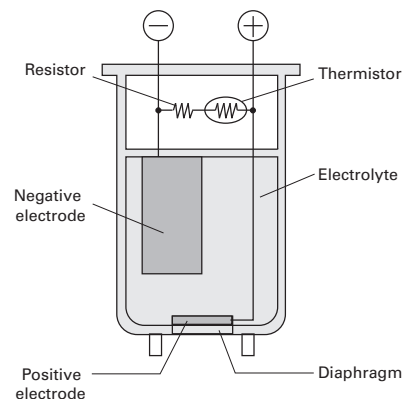

Examples of sampling system configuration including gas analyzer (for reference only)

To measure low moisture content (saturated at room temperature or lower) sample gas (CO, CO₂, CH₄)

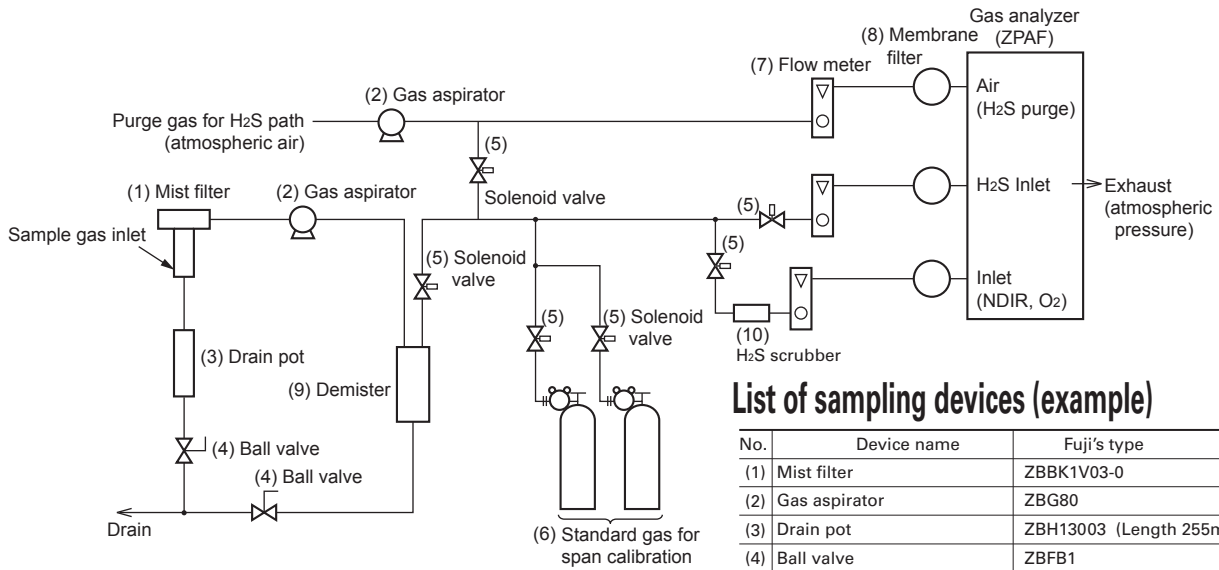

List of sampling devices (example)

No.	Device name	Fuji's type
(1)	Mist filter	ZBBK1V03-0
(2)	Gas aspirator	ZBG80
(3)	Drain pot	ZBH13003 (Length 255mm)
(4)	Ball valve	ZBFB1
(5)	Two-way solenoid valve	
(6)	Standard gas for calibration	ZBM□Y04-0□ (Codes in □ to be selected depending on application)
(7)	Flow meter	ZBD42203
(8)	Membrane filter	ZBBM2V03-0
(9)	Demister	ZBH35003
(10)	H ₂ S scrubber	ZBBB4V03

Note) The above is a typical configuration example. As configuration may differ depending on measuring objects, please consult us.

Mounting method

The analyzer weight should be supported at the bottom of the case.

19-inch rack mounting type

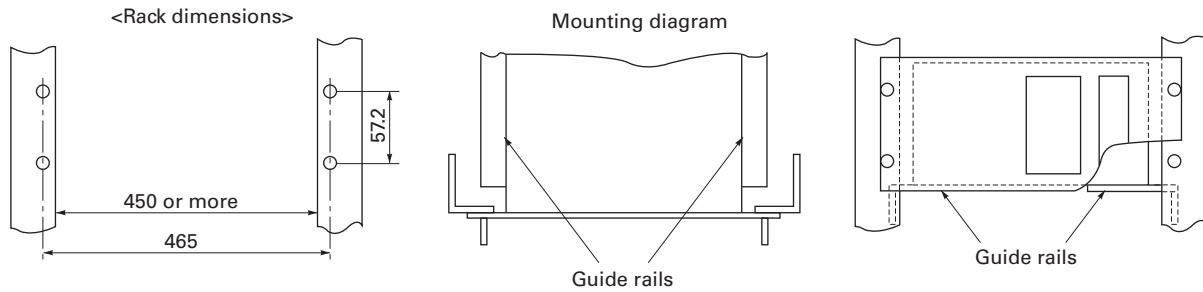

EXTERNAL CONNECTION

<Analog output> A/O connector

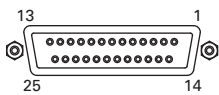

D-sub 25pins female

* In standard, displayed Channel No. and Analog Output No. are same.

<Screw terminal (M4)>

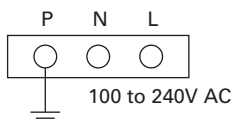

<Power inlet>

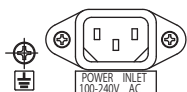

<RS485 communication signal>

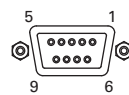
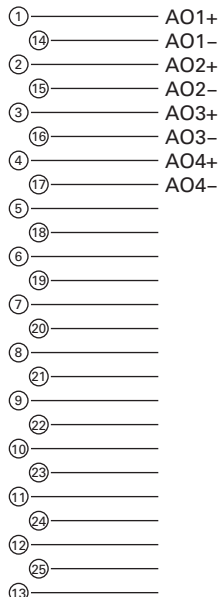

D-sub 9pins female

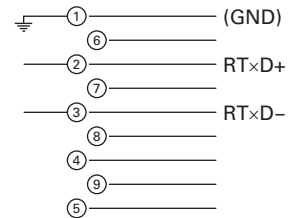

<Digital I/O> DIO 1 to 3 connector (option)

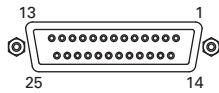

D-sub 25pins female

* DIO 1 to 3 are all as same connector.

Contents of digital input signal

DI1	Remote hold
DI2	Average value reset
DI3	A. cal. start
DI4	A. zero. cal. start
DI5	Remote range Ch1
DI6	Remote range Ch2
DI7	Remote range Ch3
DI8	Remote range Ch4
DI9	Remote range Ch5

Allocation table of digital input signal

22th digit →	A	B	C	D	E	F	G	H	Y
DI1	○	○	○	○	○	○	○	○	
DI2	○	○	○	○	○	○	○	○	
DI3		○			○		○	○	
DI4		○			○		○	○	
DI5				○		○	○	○	
DI6				○*		○*	○*	○*	
DI7				○*		○*	○*	○*	
DI8				○*		○*	○*	○*	
DI9				○*		○*	○*	○*	

○ sign shows the function is valid.

* : The function might be invalid depending on the number of measurable components.

For example: DI5 corresponds to 1st component, DI6 corresponds to 2nd components.

Contents of digital output signal

22th digit →	Independent on the number of component	1-component analyzer		2-component analyzer	3-component analyzer
		B, E	D, F, G, H	B, D, E, F, G, H	B, D, E, F, G, H
DO1	Instrument error	Instrument error	Instrument error	Instrument error	Instrument error
DO2	Calibration error	Calibration error	Calibration error	Calibration error	Calibration error
DO3		A.cal.status	(A.cal.status)	(A.cal.status)	(A.cal.status)
DO4		For zero gas	(For zero gas)	(For zero gas)	(For zero gas)
DO5		For span gas Ch1	(For span gas Ch1)	(For span gas Ch1)	(For span gas Ch1)
DO6	(Alarm1)	(Alarm1)		(For span gas Ch2)	(For span gas Ch2)
DO7	(Alarm2)	(Alarm2)			(For span gas Ch3)
DO8	(Alarm3)	(Alarm3)			(Range identification Ch1)
DO9	(Alarm4)	(Alarm4)		(Range identification Ch1)	(Range identification Ch2)
DO10	(Alarm5)	(Alarm5)	Range identification Ch1	(Range identification Ch2)	(Range identification Ch3)
DO11			(Alarm1)	(Alarm1)	(Alarm1)
DO12			(Alarm2)	(Alarm2)	(Alarm2)
DO13			(Alarm3)	(Alarm3)	(Alarm3)
DO14			(Alarm4)	(Alarm4)	(Alarm4)
DO15			(Alarm5)	(Alarm5)	(Alarm5)

22th digit →	4-component analyzer			
	B, E	D, F	G	H
DO1	Instrument error	Instrument error	Instrument error	Instrument error
DO2	Calibration error	Calibration error	Calibration error	Calibration error
DO3	A.cal.status		A.cal.status	A.cal.status
DO4	For zero gas		For zero gas	For zero gas
DO5	For span gas Ch1		For span gas Ch1	For span gas Ch1
DO6	For span gas Ch2		For span gas Ch2	For span gas Ch2
DO7	For span gas Ch3	Range identification Ch1	For span gas Ch3	For span gas Ch3
DO8	For span gas Ch4	Range identification Ch2	For span gas Ch4	For span gas Ch4
DO9		Range identification Ch3		Range identification Ch1
DO10		Range identification Ch4		Range identification Ch2
DO11	(Alarm1)	(Alarm1)		(Alarm1)
DO12	(Alarm2)	(Alarm2)	Range identification Ch1	(Alarm2)
DO13	(Alarm3)	(Alarm3)	Range identification Ch2	(Alarm3)
DO14	(Alarm4)	(Alarm4)	Range identification Ch3	Range identification Ch3
DO15	(Alarm5)	(Alarm5)	Range identification Ch4	Range identification Ch4

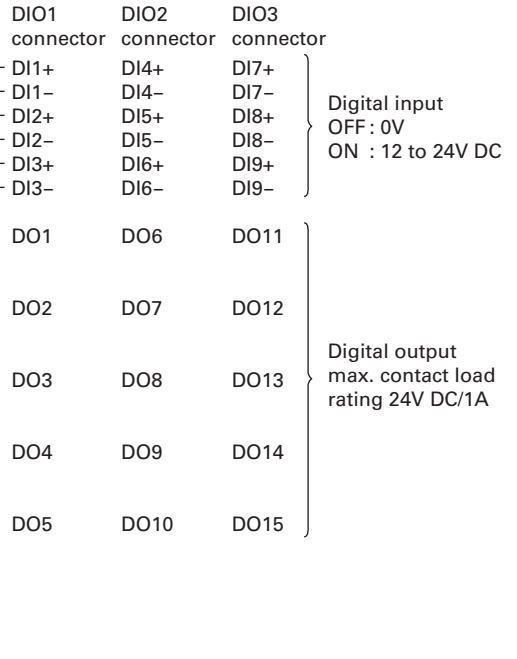

Digital input
OFF : 0V
ON : 12 to 24V DC

Digital output
max. contact load
rating 24V DC/1A

The items in the parentheses may not be available depending on the selected type on 22th digit.

The normal open side (NO) of digital output is close when the function is active without range ID.

In case of range ID, normal open (NO) side is close with First range.

The normal close (NC) side is close with Second range.

OUTLINE DIAGRAMS (Unit : mm)

<TOP VIEW>

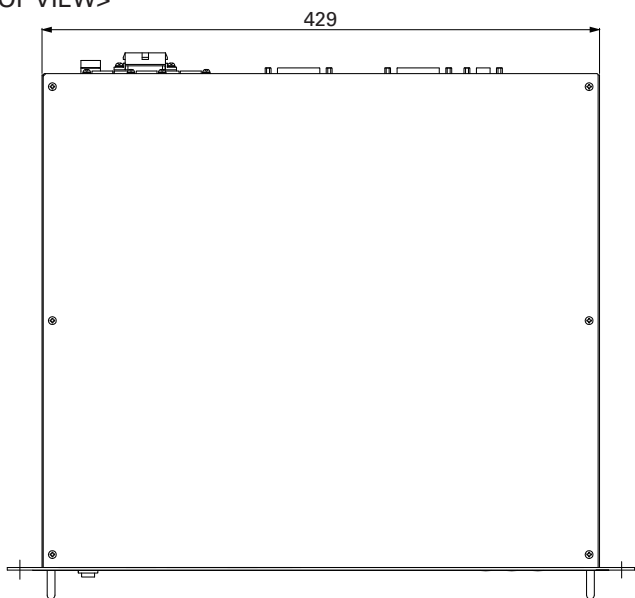

<FRONT VIEW>

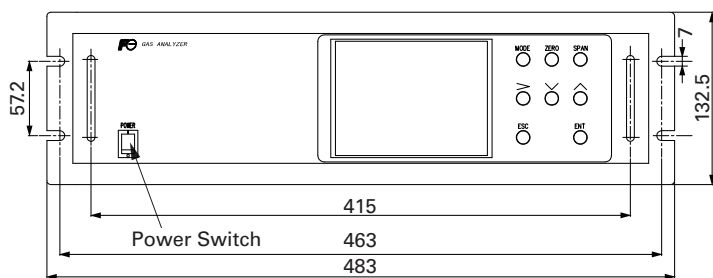

<SIDE VIEW>

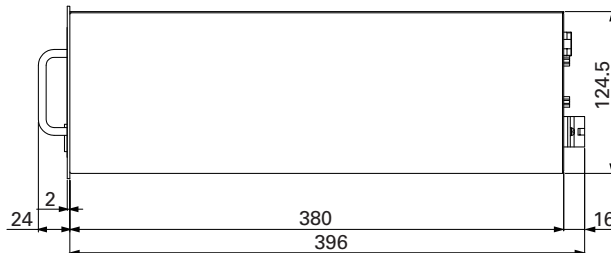

<REAR VIEW>

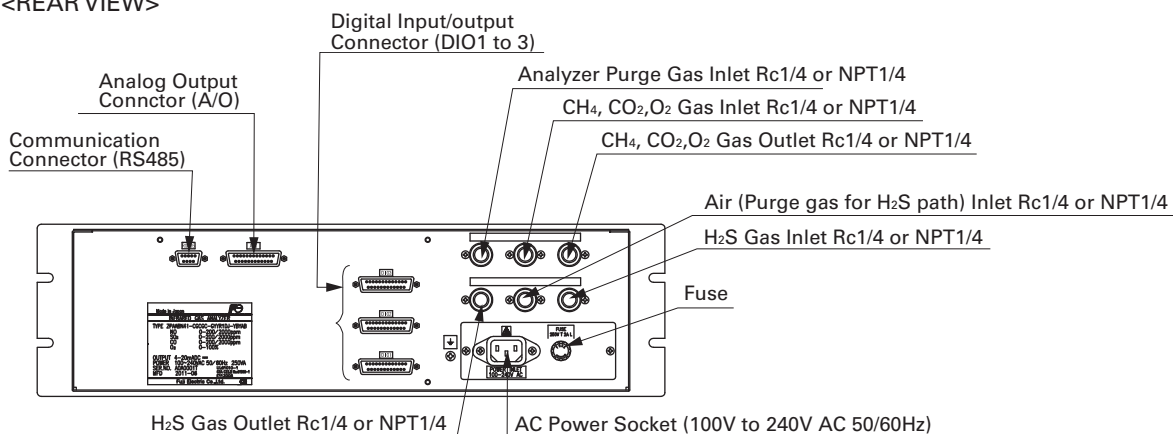

⚠ Caution on Safety

*Before using this product, be sure to read its instruction manual.

F Fuji Electric Co., Ltd.

Instrumentation & Sensors Planning Dept.
 1, Fuji-machi, Hino-city, Tokyo 191-8502, Japan
<http://www.fujielectric.com>
 Phone: +81-42-514-8930 Fax: +81-42-583-8275
<http://www.fujielectric.com/products/instruments/>