



Fuji IGBT Modules for MV , SVG Inverter

2022.10

Device Application Technology Dept.
Sales Division
Semiconductors Business Group

- **Topology in MV , SVG inverter**
- Fuji's solutions for MV , SVG inverter
- Introduction of Gate Driver Unit (GDU) and Snubber capacitors

Topology in MV , SVG inverter

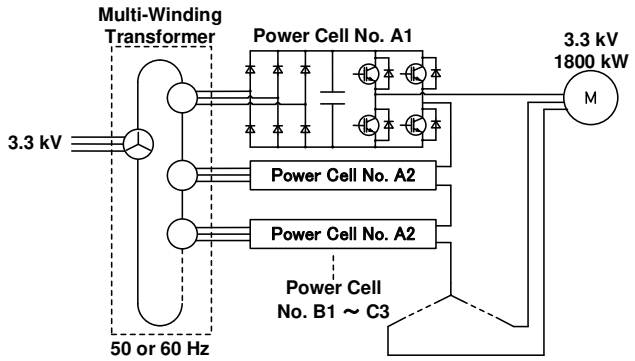
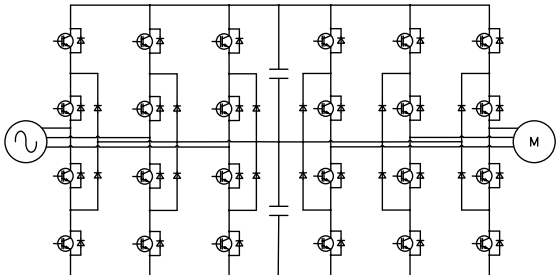
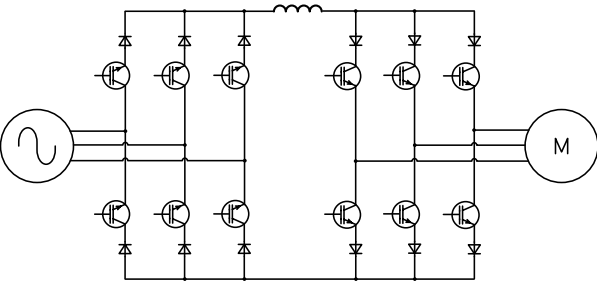
	Topology (example)	Feature	Applicable device	Applicable rate
Unit serial multi-level		<ul style="list-style-type: none"> • Topology is simple, easy maintenance, any output voltage can be obtained by unit cell serials • Input-Transformer is necessary (high cost) 	<p>1700V/100A ~ 1200A Standard Module</p>	<p>60% Around the world (China etc.)</p>
Direct 3 level Inverter		<ul style="list-style-type: none"> • Transformer less • Topology is complicated 	<p>3.3kV/800 ~ 1500A 4.5kV/ 400A ~ 1500A HPM</p>	<p>30% Europe and America</p>
Current type Inverter		<ul style="list-style-type: none"> • Reverse-blocking diode is necessary (Large loss) 	<p>6.5kV/400A ~ 1500A Press Pack(GCT)</p>	<p>10% Europe and America</p>

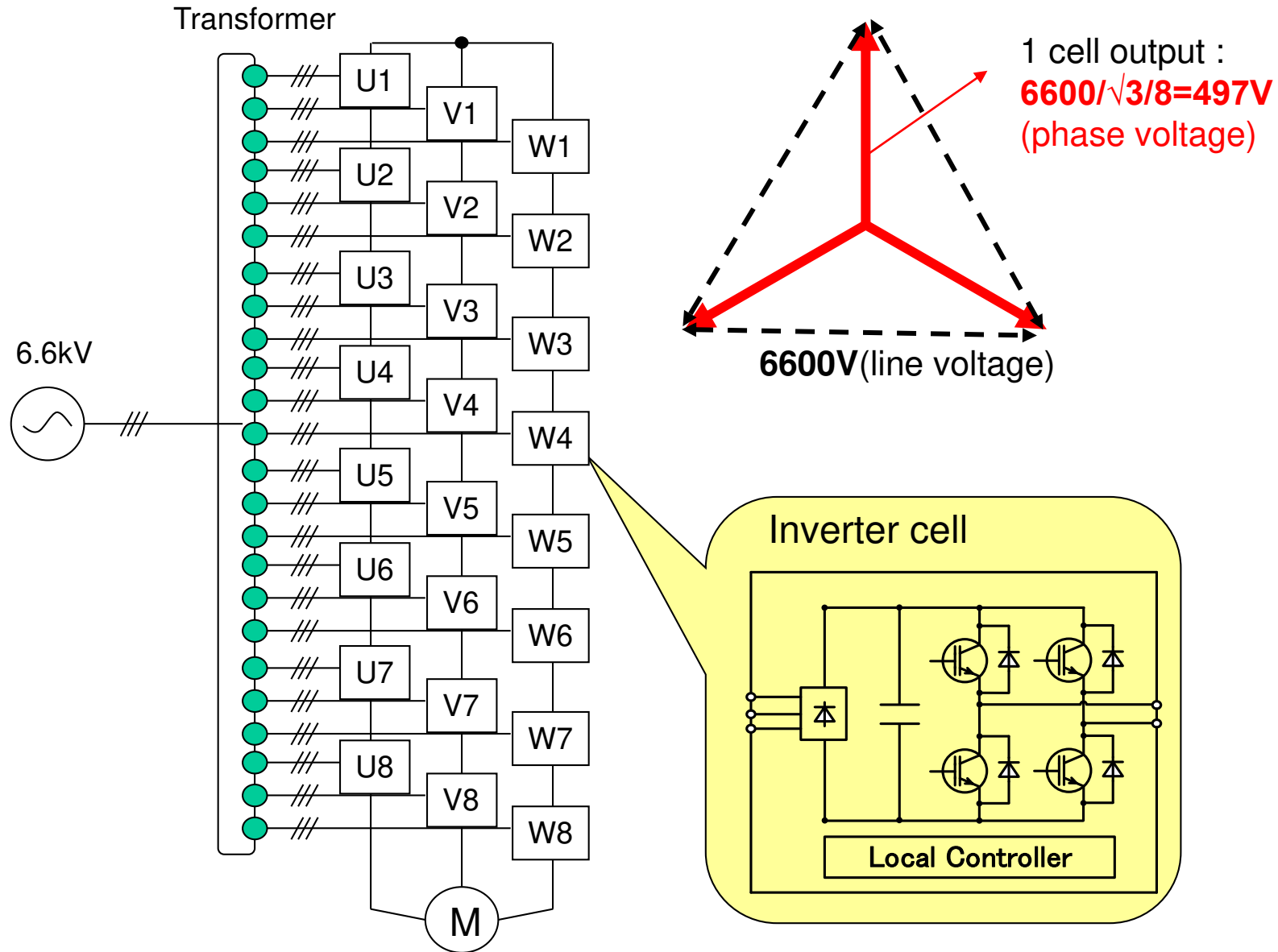

Field	Application	Topology			Function
		Unit serial multi-level	Direct 3 level	Current type	
Electric	Dust collecting fan	○	○	○	
	Boiler	○	○	○	
	Circulation pump	○	○	○	
Petroleum	Oil transfer pump	○	○	○	
	Ventilation fan	○	○	○	
	Compressor	-	○	○	Regeneration
Steel	Rolling	○	○	○	
	Ventilation fan	○	○	○	
	Pump	○	○	○	
Cement	Cooler dust collector	○	○	○	
	Material mill	○	○	○	
	Fan	○	○	○	
Paper	Pulp mill	-	○	○	Regeneration
Mining	Exhaust fan	○	○	○	
	Ventilation fan	○	○	○	
Transport	Conveyor	-	○	○	Regeneration
	Crane	-	○	○	Regeneration

Topology - Unit serial multi-level circuit (6.6kV output)





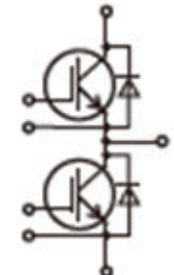



- Topology in MV , SVG inverter
- Fuji's solutions for MV , SVG inverter
- Introduction of Gate Driver Unit (GDU) and Snubber capacitors

Fuji IGBT modules for MV , SVG inverter - Standard 2in1

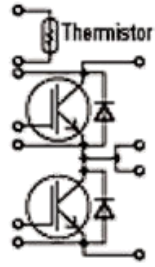
	V series		X series		Voltage	Package	Equivalent circuit
	Device type ^{※1}	Current	Device type ^{※1}	Current			
Standard 2in1	2MBI**VA-170-50	75A 100A	2MBI**XAA170-50	75A 100A 150A	1700V	M263:94 x 34 x 30mm 	
	2MBI**VH-170-50	150A 200A 300A	2MBI**XHA170-50	150A 200A 300A 400A	1700V	M276:108 x 62 x 30.5mm 	
	2MBI**VE-170-50	300A 400A	2MBI**XEE170-50	300A 400A	1700V	M277:110 x 80 x 30mm 	

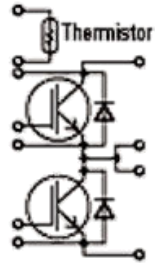

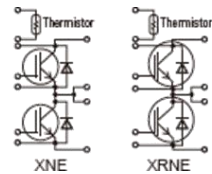
※1 “***” is rated current.

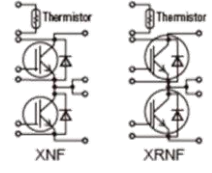
Fuji IGBT modules for MV , SVG inverter - Dual XT

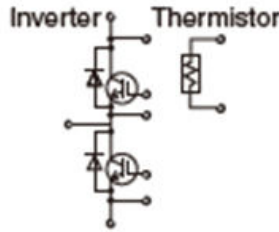

	V series		X series		Voltage	Package	Equivalent circuit
	Device type ^{※1}	Current	Device type ^{※1}	Current			
Dual XT	2MBI**VN-170-50	300A 450A 550A	2MBI**XNA170-50	225A 300A 450A	1700V	M254:150 x 62 x 17mm Solder pins 	
	—	—	2MBI600XNG170-50	600A	1700V		
	2MBI**VX-170-50	225A 300A 450A 550A	2MBI**XNB170-50	225A 300A 450A	1700V	M282:150 x 62 x 17mm Press fit pins 	
	—	—	2MBI600XNH170-50	600A	1700V		
	—	—	2MBI600XNE170-50	600A	1700V	M285:150 x 62 x 17mm Solder pins 	
	—	—	2MBI800XRNE170-50	800A	1700V		
	—	—	2MBI600XNF170-50	600A	1700V	M286:150 x 62 x 17mm Press fit pins 	
	—	—	2MBI800XRNF170-50	800A	1700V		

※1 “**” is rated current.

Fuji IGBT modules for MV , SVG inverter - PrimePACK™

	V series				Voltage	Package	Equivalent circuit
	Low switching loss		Soft turn off				
	Device type※1	Current	Device type	Current			
PrimePACK™	2MBI650VXA-170E-50 2MBI650VXA-170E-54 2MBI650VXA-170EA-50 2MBI650VXA-170EA-54	650A	-	-	1700V	M271:172 x 89 x 38mm 	
	2MBI**VXB-170E-50 2MBI**VXB-170E-54	1000A 1400A	-	-	1700V	M272:250 x 89 x 38mm 	
	2MBI1000VXB-170EA-50 2MBI1000VXB-170EA-54	1000A	2MBI1400VXB-170P-50 2MBI1400VXB-170P-54	1400A	1700V		

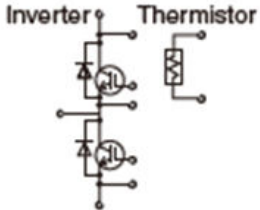
※1 “***” is rated current.

	X series		Voltage	Package	Equivalent circuit
	Low switching loss				
	Device type※1	Current			
PrimePACK™	2MBI650XXA170-50	650A	1700V	M271:172 x 89 x 38mm 	
	2MBI1200XXE170-50	1200A	1700V		
	2MBI**XXB170-50	1000A 1400A	1700V	M272:250 x 89 x 38mm 	
	2MBI1800XXF170-50	1800A	1700V		
	2MBI1800XXG170-50	1800A	1700V	M291:250 x 89 x 38mm 	

※1 “***” is rated current.

Note: PrimePACK™ is registered trademarks of Infineon Technology AG, Germany.

Fuji IGBT modules for MV , SVG inverter

AC output voltage	Inverter capacity (kVA)	Serial	Device rating	Device type	
				V series	X series
3.3 kV	350	4	1700V/100A	2MBI100VA-170-50	2MBI100XAA170-50
	500	4	1700V/150A	2MBI150VH-170-50	2MBI150XAA170-50 2MBI150XHA170-50
	700	4	1700V/200A	2MBI200VH-170-50	2MBI200XHA170-50
	1050	4	1700V/300A	2MBI300VN-170-50 2MBI300VX-170-50	2MBI300XNA170-50 2MBI300XNB170-50
	1350	4	1700V/450A	2MBI450VN-170-50 2MBI450VX-170-50	2MBI450XNA170-50 2MBI450XNB170-50
	1600	4	1700V/300A×2p	2MBI300VN-170-50 2MBI300VX-170-50	2MBI300XNA170-50 2MBI300XNB170-50
6.6 kV	720	8	1700V/100A	2MBI100VA-170-50	2MBI100XAA170-50
	1090	8	1700V/150A	2MBI150VH-170-50	2MBI150XAA170-50 2MBI150XHA170-50
	1450	8	1700V/200A	2MBI200VH-170-50	2MBI200XHA170-50
	2180	8	1700V/300A	2MBI300VN-170-50 2MBI300VX-170-50	2MBI300XNA170-50 2MBI300XNB170-50
	2900	8	1700V/450A	2MBI450VN-170-50 2MBI450VX-170-50	2MBI450XNA170-50 2MBI450XNB170-50
	3490	8	1700V/300A×2p	2MBI300VN-170-50 2MBI300VX-170-50	2MBI300XNA170-50 2MBI300XNB170-50
10 kV	1200	12	1700V/100A	2MBI100VA-170-50	2MBI100XAA170-50
	1800	12	1700V/150A	2MBI150VH-170-50	2MBI150XHA170-50 2MBI150XAA170-50
	2400	12	1700V/200A	2MBI200VH-170-50	2MBI200XHA170-50
	3600	12	1700V/300A	2MBI300VN-170-50 2MBI300VX-170-50	2MBI300XNA170-50 2MBI300XNB170-50
	4800	12	1700V/450A	2MBI450VN-170-50 2MBI450VX-170-50	2MBI450XNA170-50 2MBI450XNB170-50
	5800	12	1700V/300A×2p	2MBI300VN-170-50 2MBI300VX-170-50	2MBI300XNA170-50 2MBI300XNB170-50

- Topology in MV , SVG inverter
- Fuji's solutions for MV , SVG inverter
- Introduction of Gate Driver Unit (GDU) and Snubber capacitors

Introduction of GDU for MV , SVG inverter ($V_{CES} = 1700V$)



I_C rating (A)	IGBT part No.	Driver part No.
75	2MBI75VA-170-50	2CG010BBC11N 2CG010DBC11N
100	2MBI100VA-170-50	
150	2MBI150VH-170-50	
200	2MBI200VH-170-50	
225	2MBI225XNA170-50	2EG01XCCN11N 2EG01XCDN11N
300	2MBI300VN-170-50	
	2MBI300XNA170-50	
450	2MBI450VN-170-50	
	2MBI450XNA170-50	
550	2MBI550VN-170-50	



I_C rating (A)	IGBT part No.	Driver part No.	"xx" (driver version)
300	2MBI300VN-170-50	2SP0115T2xx -2MBI300VN-170-50	A0, A0C, B0, B0C
450	2MBI450VN-170-50	2SP0115T2xx -2MBI450VN-170-50	
550	2MBI550VN-170-50	2SP0115T2xx -2MBI550VN-170-50	



<https://www.idc-com.co.jp/en/>

I_c rating (A)	IGBT part No.	Driver part No.				
		Hybrid IC type	Mounted unit type	Mounted unit type with clamp circuit	Adapter unit for parallel drive	Drive unit for parallel drive
75	2MBI75VA-170-50	VLA546, VLA551K, VLA597	-	-	-	-
100	2MBI100VA-170-50		-	-	-	-
150	2MBI150VH-170-50		-	-	-	-
200	2MBI200VH-170-50		-	-	-	-
300	2MBI300VN-170-50		VLA598-01R	VLA598-11R	VLB520-01R	GAU220P-15402 GAU240P-15405
450	2MBI450VN-170-50	VLA574, VLA500K, VLA597	VLA598-01R	VLA598-11R	VLB520-01R	GAU220P-15402 GAU240P-15405

$$C_s = \frac{L * I_o^2}{(V_{CEP} - E_d)^2}$$

- L: Main circuit wiring parasitic inductance
- I_o: Collector current at IGBT turn-off
- V_{CEP}: Snubber capacitor peak voltage
- E_d: DC supply voltage

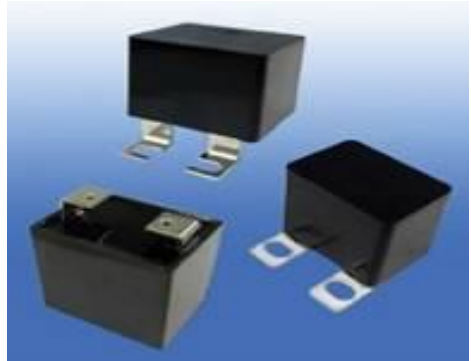

Module rating		DC line inductance	snubber capacitance
V _{CES}	I _c		
1200V/1700V	100A	0.2 μH	0.47 μF
	300A	0.1 μH	3.3 μF
	450A	0.08 μH	4.7 μF
	1000A	0.07 μH	6.8 μF
	1400A	0.06 μH	12 μF



The information contained in this material is intended to assist in design and does not guarantee functionality, conditions, quality or application or its characteristics.
This information never ensure to enforce the industrial property and other rights, nor license the enforcement rights.
When using the contents of this document, please evaluate it in the application in which it will be used, and then judge the applicability at user's own risk. Fuji Electric is not responsible for the applicability.