

PUMV/N/T is usable Analog I/O module as the accessory I/O of PUM series. Each control module, 30mm wide, is equipped the follows. PUMV is equipped 4 points of analog input/output. PUMN is equipped 4points of analog input. PUMT is equipped 4points of analog output. And all models are equipped high-speed RS-485 port. By connecting with PUM control modules, it realizes a compact and high-performance system.

FEATURES

- I. **User-friendly structure and functions**
 1. Lateral connection with control module: Max.16 units (64 channels) + event input/output module 16 units = total 32 units
Simple wiring for power supply and communication
 2. Detachable structure: Terminal block, main unit, and the base part
→ Easy wiring with detachable terminal block
→ Main units exchangeable without re-wiring
 3. Status LED for each input/output
→ Easy to detect input status and output status
 4. Smart loader communication: Connect one module and all connected modules are able to communicate using a loader software.
- II. **Large scale system using high speed RS-485**
 1. Modbus RTU protocol for large volume communication
 2. High-speed communication: Maximum 115.2kbps
 3. Highly-efficient communication: Parameters dispersed on the address map are re-allocated to contiguous address
- III. **Various functions to enhance the control module functions**
 1. Analog input
 - Remote SV
 2. Analog output
 - Control output (included distribution output)
 - Re-transmission output



SYSTEM SPECIFICATION

1. **Product type:** Multi-loop module type temperature controller
2. **Module types**
 - 1) Analog module: 16 units maximum
 - Control module (4 loops per unit)
 - Analog input/output module (4 points each per unit)
 - Analog input module (4 points per unit)
 - Analog output module (4 points per unit)
 - 2) Digital module: 16 units maximum
 - Event input/output module (8 points each per unit)
 - 3) Communication module: 1 unit
3. **Connecting method:**
 - Lateral connecting with connectors
 - For power supply and RS-485 communication, any one of connected modules is required to be connected.
4. **No. of loop, input/output**
 - 1) Control loop: Max. 64
 - 2) No.of input/output: DI 128 points / DO 128 points

ANALOG I/O MODULE SPECIFICATION

1. General specification

- (1) Power supply: 24V DC $\pm 10\%$
- (2) Power consumption: Max. 3.2 W (135 mA)
[when 24V DC is applied]
- (3) Insulation resistance: 20M Ω or more (500V DC)
- (4) Withstand voltage:
 - Power supply \leftrightarrow all terminals
1000V AC 1 min.
 - Others
500V AC 1 min.

2. Input (PUMV, PUMN only)

- (1) No. of input: 4 points (4 ch)
- (2) Input setting: Input code selection
- (3) Input signal: See table 1
Select from group I or II depending on the model code.
(setting can be done by points within group)
 - [Group I] a) Thermocouple
b) Resistance bulb (3 wire)
 - [Group II] c) DC voltage, current
- (4) Measurement range and input type: See table 1
- (5) Measurement accuracy (Ta = 23°C):
 - Thermocouple: $\pm 0.3\%FS \pm 1\text{digit} \pm 1^\circ\text{C}$ or $\pm 3^\circ\text{C}$ whichever is greater
 - * Unless
 - B thermocouple 0 to 400°C
: $\pm 5\%FS \pm 1\text{digit} \pm 1^\circ\text{C}$
 - R thermocouple 0 to 500°C
: $\pm 1\%FS \pm 1\text{digit} \pm 1^\circ\text{C}$
 - T thermocouple -200 to 0°C
: $\pm 0.5\%FS \pm 1\text{digit} \pm 1^\circ\text{C}$
 - Resistance bulb input
: $\pm 0.3\%FS \pm 1\text{digit} \pm 1^\circ\text{C}$
whichever is greater
 - Voltage/Current input
: $\pm 0.3\%FS \pm 1\text{digit}$
- (6) Resolution: See table 1
- (7) Temperature fluctuation: $\pm 0.3\%FS \pm 10^\circ\text{C}$
- (8) Input sampling cycle: 200ms
- (9) Input impedance:
 - Thermocouple: 1M Ω or more
 - Current input: 250 Ω
 - Voltage input: approx. 1 M Ω
- (10) Influence of signal source resistance:
 - Thermocouple: $\pm 0.3\%FS \pm 1\text{digit}/100\Omega$
 - Voltage input: $\pm 0.3\%FS \pm 1\text{digit}/500\Omega$
- (11) Allowable wiring resistance:
 - Resistance bulb: 10 Ω or less (per wire)
- (12) Allowable input voltage:
 - DC voltage input: within $\pm 15\text{V}$
 - Current input : within $\pm 25\text{mA}$
 - Thermocouple/resistance bulb: within $\pm 5\text{V}$
- (13) Noise rejection ratio:
 - Normal mode : 30dB or more (50/60Hz)
 - Common mode : 120dB or more (50/60Hz)
between process value input and earth,
power supply, output 220V AC, 50/60Hz
- (14) Input compensation:
 - a) User adjustment : zero point, span point $\pm 50\%FS$
 - b) Input value : $\pm 10\%FS$
 - c) First order lag filter : 0.0 to 120.0 sec.
- (15) Over range, Under range:
 - Out of range of -5 to 105%FS
(Accuracy cannot be ensured for -5 to 0,
100 to 105% FS)

- (16) Insulation: Functional insulation between channels, and with any other input/output

3. Output (PUMV, PUNT only)

- (1) No. of output: 4 points
- (2) Output type: Current output (4-20mA DC, 0-20mA DC)
 - Actual output range: 0mA to 20.6mA DC
 - Accuracy: $\pm 0.3\%FS$
(less than 1mA : $\pm 5\%FS$)
 - Linearity : $\pm 0.3\%FS$
(less than 1mA : $\pm 5\%FS$)
 - Resolution: 5,000 or more
 - Ripple current: P-P 0.3mA or less
 - Load resistance: 300 Ω or less
 - Insulation: No insulation between outputs
Functional insulation other than output
- (3) Output functions: Output limit, output scaling

4. Communication function

4.1 RS-485 interface

- (1) Communication standards: RS-485 compatible
- (2) No. of port: 1 port
- (3) Communication, synchro method:
Two-wire, half-duplex, asynchronous cycle
- (4) Communication speed: 9.6k, 19.2k, 38.4k, 115.2kbps
- (5) Communication distance: 1km (38.4kbps or less),
250m (115.2kbps)
- (6) Recommended cable: KPEV-SB 0.5sq-equivalent
- (7) No. of connectable units:
33 units (Master and slave)
(32 units if any modules other than PUM series are included in slaves.)
- (8) Data format: Data bit; 8, parity; even / odd / none
- (9) Protocol: Modbus RTU compatible
- (10) Insulation: No insulation with loader communication port
Functional insulation with any other input/output

4.2 Loader communication (RS-232C) interface

- (1) Communication standards: RS-232C compatible
- (2) No. of port: 1 port
- (3) Communication, synchro method:
Half-duplex, asynchronous cycle
- (4) Communication speed: 19.2kbps (fixed)
- (5) Data format: Data bit 8, no parity
- (6) Protocol: Modbus RTU compatible
- (7) Connection method:
2.5 diameter mini-plug/jack
[on the front of the module]
(Common cable with PXG, PXH)
- (8) Insulation: No insulation with RS-485 communication
Functional insulation with any other input/output

5. Display, configuration

5.1 Display

- (1) Display: Status display LED
(2 colors \times 6 points)
- (2) Display contents:
RUN/FAULT, RS-485 TX/RX, OUT/ERR by loop (4 loops) (Functions are assigned to LED of each channel)

5.2 Setting device

- (1) Setting device: Rotary SW × 1
- (2) Set contents: RS-485 Station No.
(Station No.= setting value + 1)

6. Power outage

- (1) Impact of power outage:
Outage of 2ms or less ; no impact
- (2) Operation after power outage:
Start from the first step (cold start)
- (3) Memory backup:
Non volatile memory (EEPROM)
No. of update ; 100,000

7. Self diagnosis

- Diagnosis method:
Program error monitoring by watch dog timer

8. Structure

- (1) Installation method:
DIN rail mounting or mounting with M3 screws inside a cabinet
- (2) Dimensions: 30 (W) × 100 (H) × 85 (D) mm
(excluding terminal cover and projected part)
- (3) Weight: Approx. 200 g
- (4) External terminal
 - Process value input/control output:
Detachable terminal block
(M3 screw × 20 terminals)
 - Power supply connection:
Terminal block on the base part
(M3 screw × 2 terminals)
Power is supplied via side connectors in case of lateral connecting. (Max. 33 units)
 - RS-485 communication connection:
Terminal block on the base part
(M3 screw × 3 terminals)
RS-485 communication is connected via side connectors in case of lateral connecting.
 - Loader communication port:
2.5 diameter 3 prong mini-plug/jack
[on the front of the module]
- (5) Case material: Polyphenylene oxide
(flame retardant grade : UL94V-0 equivalent)
- (6) Case color: Case ; red
Terminal, base part ; black
- (7) Protection
 - Body: IP20 grade protection
(ventilation slits on the top and the bottom of the body)
 - Terminal: IP00 grade protection, terminal cover is available as an option

9. Normal operating condition

- (1) Ambient temperature*: -10 to 50°C
 - * "Ambient temperature" is the temperature underneath the controller inside the equipment or the cabinet where the controller is installed.

- (2) Ambient humidity:
90% RH or less (non condensing)
- (3) Vibration: 10 to 70Hz, 9.8m/s² (1G) or less
- (4) Warmup time:30 min. or more

10. Transporting, storage condition (packing condition)

- (1) Storage temperature: -20°C to 60°C
- (2) Ambient humidity: 90%RH or less (no condensing)
- (3) Vibration: 10 to 70Hz, 9.8m/s² (1G) or less
- (4) Shock: 294m/s² (30G) or less

11. Packing list

- Temperature controller: 1 unit
- Instruction manual: 1 copy
- 250Ω resistance: 0, 2, or 4
(For no. points of voltage/current input selected)

12. Loader software

- (1) Distribution medium:
Free download from Fuji Electric website
(<http://www.fujielectric.com/products/instruments/>)
- (2) Recommended operating environment
 - PC: DOS/V (PC-AT compatible)
 - OS: Windows XP (operating confirmed in Japanese / English)
 - RAM: 256M bytes or more
 - Free space on the hardware: 500M bytes or more
 - Display resolution: 1024 × 768 dots or more
 - Serial interface: RS-232C 1 port
(without RS-232C, USB serial converter cable required)
- (3) Connection with PUM
Via loader interface on the front face of the module (special cable available from Fuji is required) or via RS-485

13. Certification

UL, C-UL

14. EU Directive Compliance

- LVD (2014/35/EU)
 - EN 61010-1
 - EN 61010-2-030
- EMC (2014/30/EU)
 - EN 61326-1 (Table 2)
 - EN 55011 (Group 1 Class A)
 - EN 61000-3-2 (Class A)
 - EN 61000-3-3
- RoHS (2011/65/EU)
 - EN 50581

CODE SYMBOLS

[Analog input/output module]

		Digit → 1 2 3 4 5 6 7 8 9 10 11 12 13															
		PUMV EE1-0000															
Digit	Description																
4	< Module type > Analog I/O module [Ai/Ao 4 points]			V													
5	< Input type > Thermocouple/resistance bulb [all channel] Voltage/current [all channel] Thermocouple/resistance bulb [ch 1, 2], voltage/current [ch3, 4]					T											
						A											
						C											
10	< Operation manual > Japanese English																A B

[Analog input module]

		Digit → 1 2 3 4 5 6 7 8 9 10 11 12 13															
		PUMN YY1-0000															
Digit	Description																
4	< Module type > Analog input module[Ai 4 points]					N											
5	< Input type > Thermocouple/resistance bulb [all channel] Voltage/current [all channel] Thermocouple/resistance bulb [ch 1, 2], voltage/current [ch3, 4]							T									
								A									
						C											
10	< Operation manual > Japanese English																A B

[Analog output module]

		Digit → 1 2 3 4 5 6 7 8 9 10 11 12 13															
		PUMTYEE1-0000															
Digit	Description																
4	< Module type > Analog output module[Ao 4 points]					T											
10	< Operation manual > Japanese English																A B

[Accessories (optional)]

		Digit → 1 2 3 4 5 6 7 8															
		PUMZ*															
Digit	Description																
6	RS-485 terminating resistance															A 0 1	
7	DIN rail mounting endplate															A 0 2	
8	Side connecting terminal cover (right & left 1 set)															A 0 3	
	Front face screw terminal cover															A 0 4	
	Loader connecting cable (RS-232C)															L 0 1	

[Table 1] Input type and standard input range

Input type		Input code	Measurement range [°C]	Min. measurement unit [°C]
Resistance bulb (IEC)	Pt100Ω	2	0 to 150	0.1
		3	-150 to 300	0.1
		4	-150 to 850	1
Thermocouple	J	5	0 to 400	0.1
		6	0 to 800	0.1
	K	7	0 to 400	0.1
		8	0 to 800	0.1
		9	0 to 1200	1
	R	10	0 to 1600	1
	B	11	0 to 1800	1
	S	12	0 to 1600	1
	T	13	-199 to 400	0.1
	E	14	-199 to 800	0.1
N	18	0 to 1300	1	
PL-II	19	0 to 1300	1	
DC voltage	DC0 to 5V	21	-1999 to 9999 (scaling range)	—
	DC1 to 5V	22		
	DC0 to 10V	23		
	DC2 to 10V	24		

[Table 2] Insulation block diagram

Power	PV1
Loader communication port RS-485 communication port	PV2
	PV3
	PV4
	OUT1 (Current) OUT2 (Current) OUT3 (Current) OUT4 (Current)

==== Functional insulation (1000V AC) — Functional insulation (500V AC)

OUTLINE DIAGRAM (Unit : mm)

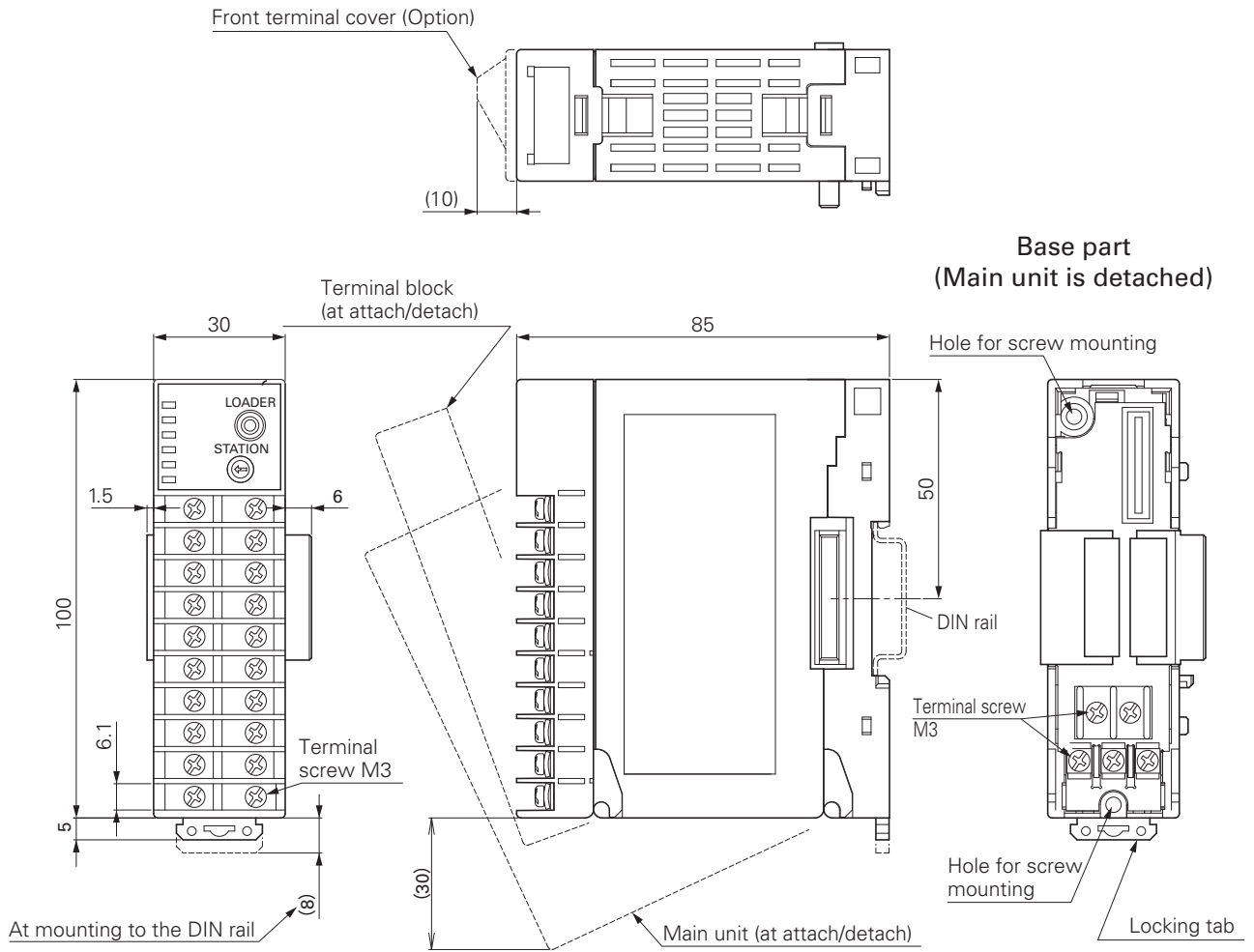

Dimensions for screw mounting

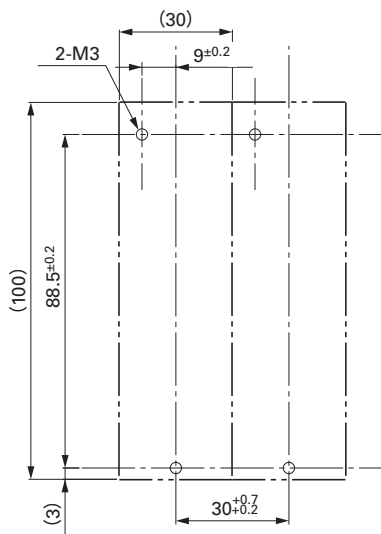

Notice at the installation

Please keep the distance of 30mm from this instrument to radiate.
[50mm is recommended]

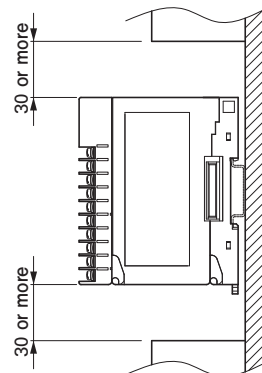

TERMINAL CONNECTION DIAGRAM

(Analog I/O module [PUMV])

Loader interface plug (RS-232C)

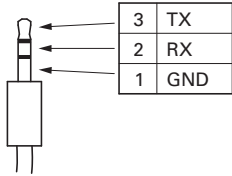

φ2.5 3-pole miniature plug

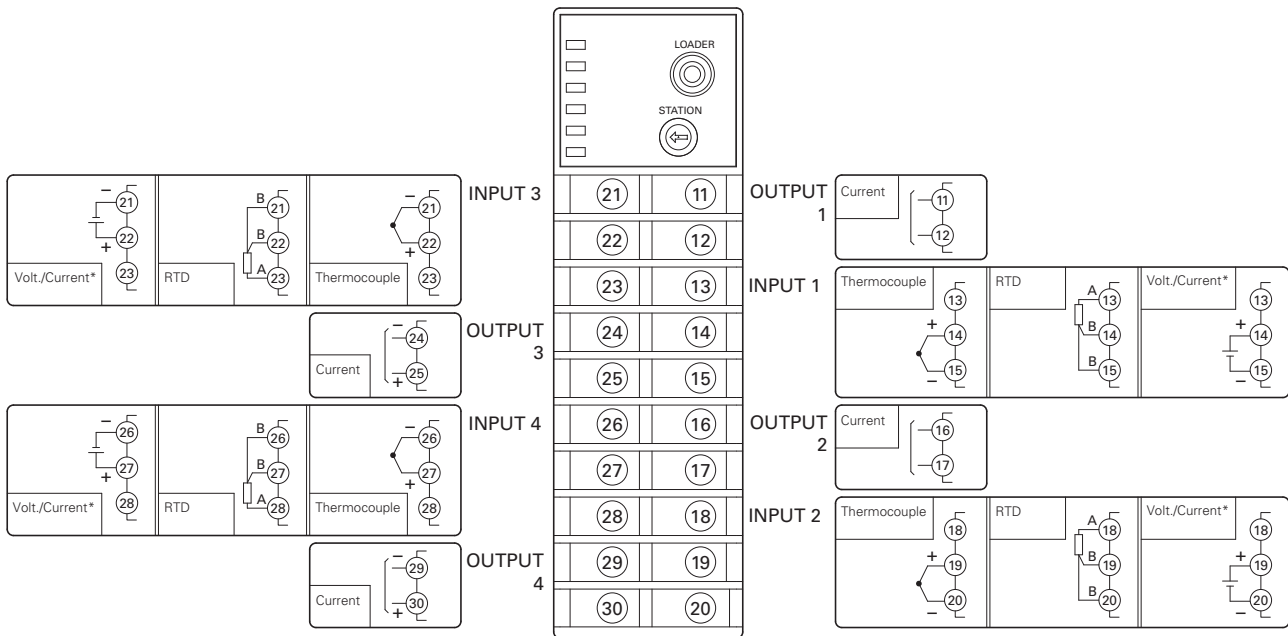

* In case of current input, attach I/V unit which comes with controller to the voltage input terminal.

Base part

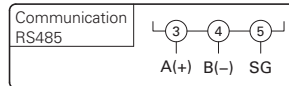
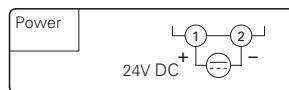
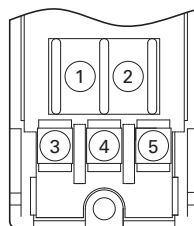

TERMINAL CONNECTION DIAGRAM

(Analog input module [PUMN])

Loader interface plug (RS-232C)

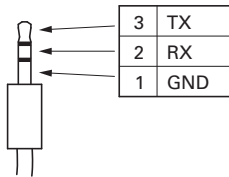

φ2.5 3-pole miniature plug

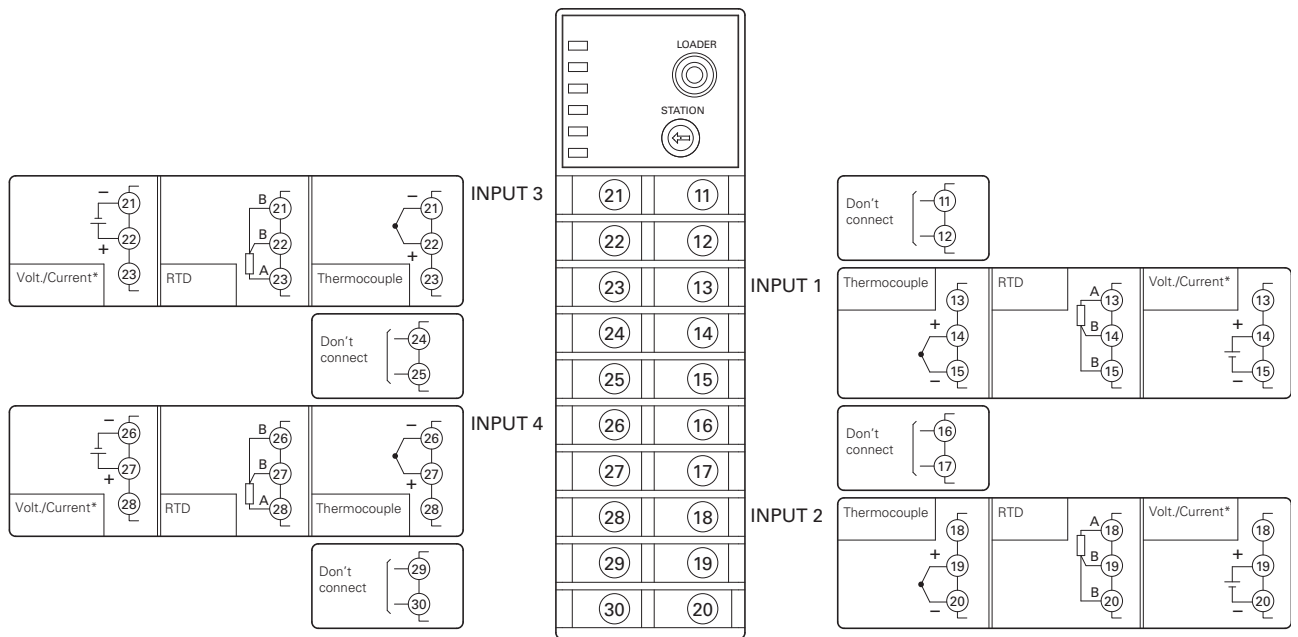

* In case of current input, attach I/V unit which comes with the controller to the voltage input terminal.

Base part

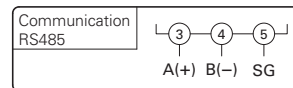
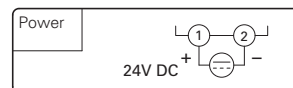
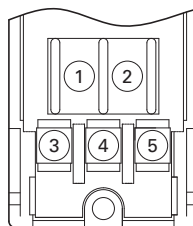

TERMINAL CONNECTION DIAGRAM

(Analog output module [PUMT])

Loader interface plug (RS-232C)

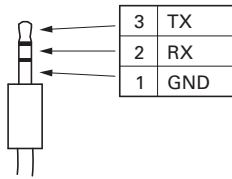

φ2.5 3-pole miniature plug

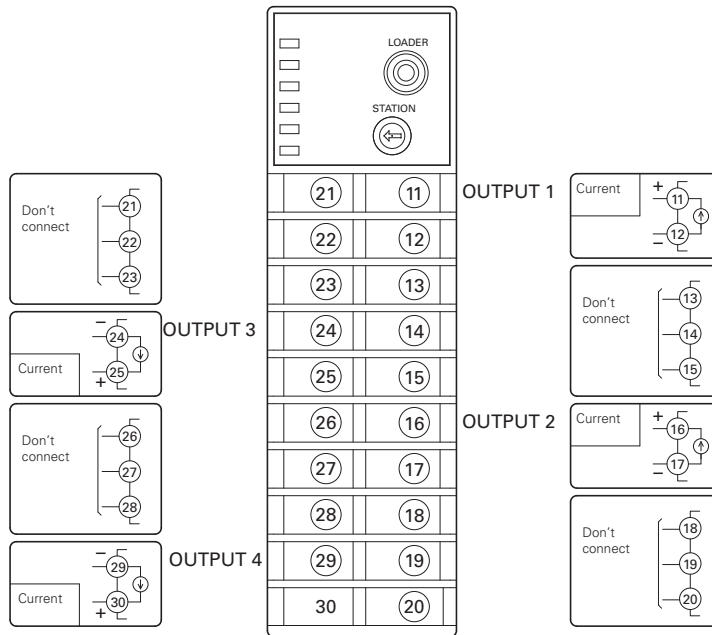

Base part

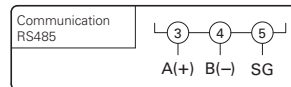
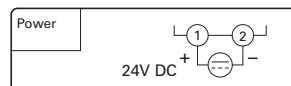
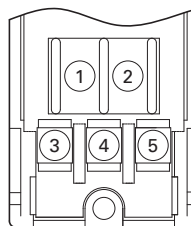

⚠ Caution on Safety

*Before using this product, be sure to read its instruction manual.

F Fuji Electric Co., Ltd.

Global Sales Section
 Instrumentation & Sensors Planning Dept.
 1, Fuji-machi, Hino-city, Tokyo 191-8502, Japan
<http://www.fujielectric.com>
 Phone: +81-42-514-8930 Fax: +81-42-583-8275
<http://www.fujielectric.com/products/instruments/>