

PUME is a digital input/output module used as an auxiliary input/output of control modules. Each module, 30mm wide, is equipped with 8 points of digital input, 8 points of digital output, and high-speed RS-485 port. By connecting with PUM control system modules, it realizes a compact and high-performance system.



FEATURES

- I. **User-friendly structure and functions**
 1. Lateral connection : Max.16 units + control module 16 units = total 32 units
Simple wiring for power supply and communication
 2. Detachable structure: Terminal block, main unit, and the base part
 - Easy wiring with detachable terminal block
 - Main units exchangeable without re-wiring
 3. Status LED for each input/output
 - Easy to monitor input/output status
 4. Smart loader communication: Connect one module and all connected modules are able to communicate using a loader software.
- II. **Large scale system using high speed RS-485**
 1. Modbus RTU protocol for large volume communication
 2. High-speed communication: Maximum 115.2kbps
 3. Highly-efficient communication: Parameters dispersed on the address map are re-allocated to contiguous address
- III. **Various functions to extend control module functions**
 1. Digital input
(Optional feature : logic operation NOT/AND/OR)
<Functions set by DI function of control module>
 - Run / Standby switch
 - Auto / Remote / Manual switch
 - Start timer
 - Others
 2. Digital output
(Optional feature : logic operation NOT/AND/OR)
 - Control output (including distribution output)
 - Alarm output
 - Timer output
 - Others

SYSTEM SPECIFICATION

1. **Product type:** Multi-loop module type temperature controller
2. **Module types**
 - 1) Analog module: 16 units maximum
 - Control module (4 loops per unit)
 - Analog input/output module (4 points each per unit)
 - Analog input module (4 points per unit)
 - Analog output module (4 points per unit)
 - 2) Digital module: 16 units maximum
 - Event input/output module (8 points each per unit)
 - 3) Communication module: 1 unit
3. **Connecting method:**
 - Lateral connecting with connectors
 - For power supply and RS-485 communication, any one of connected modules is required to be connected.
4. **No. of loop, input/output**
 - 1) Control loop: Max. 64
 - 2) No. of input/output: DI 128 points / DO 128 points

MODULE SPECIFICATION

1. General specification

- (1) Power supply: 24V DC \pm 10%
 (2) Power consumption: Max. 3.2 W (135 mA)
 [when 24V DC is applied]
 (3) Insulation resistance: 20M Ω or more (500V DC)
 (4) Withstand voltage:

Power supply \leftrightarrow digital input \leftrightarrow digital output \leftrightarrow communication terminal
 1000V AC 1 min.

Others (digital input between blocks, digital output between blocks)
 500V AC 1 min.

2. Digital Input

- (1) No. of input: 8 points (4 points/common \times 2 blocks)
 (2) Input type: Voltage contact input, sink/source common (bidirectional)
 (3) Input rating: 24V DC, input impedance approx. 4.7k Ω
 (4) Input judgment:
 ON judgment: 16 to 26.4V DC
 OFF judgment: 0 to 5V DC
 (5) Input read cycle (min. pulse width): 200ms
 (6) Insulation: Functional insulation with internal circuit
 (7) Option: NOT/AND/OR logic operation, Latch action

3. Digital Output

- (1) No. of output: 8 points (4 points/common \times 2 blocks)
 (2) Output type: Select from a) and b) according to model type specification
 a) Relay contact output
 - Contact structure: SPST contact
 - Contact capacity: 220V AC/30V DC, 1A
 - Insulation: Functional insulation with internal circuit
 b) Transistor open collector (sink) output
 - Rating: 24V DC, 100mA
 (Residual voltage when power is ON: 1.5V DC or less)
 - Insulation: Functional insulation with internal circuit
 (3) Option: Control output/Event output selection, NOT/AND/OR logic operation, Latch action

4. Communication function

4.1 RS-485 interface

- (1) Communication standards: RS-485 compatible
 (2) No. of port: 1 port
 (3) Communication, synchro method:
 Two-wire, half-duplex, asynchronous cycle
 (4) Communication speed: 9.6k, 19.2k, 38.4k, 115.2kbps
 (5) Communication distance: 1km (38.4kbps or less), 250m (115.2kbps)
 (6) Recommended cable: KPEV-SB 0.5sq-equivalent
 (7) No. of connectable units:
 33 units (master and slave)
 (32 units if any modules other than PUM series are included in slaves.)

- (8) Data format: Data bit; 8, parity; even / odd / none
 (9) Protocol: Modbus RTU compatible
 (10) Insulation: No insulation with loader communication port
 Functional insulation with any other input/output

4.2 Loader communication (RS-232C) interface

- (1) Communication standards: RS-232C compatible
 (2) No. of port: 1 port
 (3) Communication, synchro method:
 Half-duplex, asynchronous cycle
 (4) Communication speed: 19.2kbps (fixed)
 (5) Data format: Data bit 8, no parity
 (6) Protocol: Modbus RTU compatible
 (7) Connection method:
 2.5 diameter mini-plug/jack
 [on the front of the module]
 (Common cable with PXG, PXH)
 (8) Insulation: No insulation with RS-485
 Functional insulation with any other input/output

5. Display, configuration

5.1 Display

- (1) Display: Status display LED
 (2 colors \times 2 points + 16 points)
 (2) Display contents:
 RUN/FAULT, RS-485 TX/RX, Input \times 8 points, output \times 8 points

5.2 Setting device

- (1) Setting device: Rotary SW \times 1
 [on the front of the module]
 (2) Set contents: RS-485 Station No.
 (Station No.= setting value + 17)

6. Power outage

- (1) Impact of power outage:
 Outage of 2ms or less ; no impact
 (2) Operation after power outage:
 Start from the first step (cold start)
 (3) Memory backup:
 Nonvolatile memory (EEPROM)
 No. of update ; 100,000

7. Self diagnosis

- Diagnosis method:
 Program error monitoring by watch dog timer

8. Structure

- (1) Installation method:
 DIN rail mounting or mounting with M3 screws inside a cabinet
 (2) Dimensions: 30 (W) \times 100 (H) \times 85 (D) mm
 (excluding terminal cover and projected part)
 (3) Weight: Approx. 200 g

(4) Extrenal terminal

- Digital input / digital output:
Detachable terminal block
(M3 screw × 20 terminals)
- Power supply connection:
Terminal block on the base part
(M3 screw × 2 terminals)
Power is supplied via side connectors
in case of lateral connecting. (Max. 33
units)
- RS-485 communication connection:
Terminal block on the base part
(M3 screw × 3 terminals)
RS-485 communication is connected via
side connectors in case of lateral con-
necting.
- Loader communication port:
2.5 diameter mini-plug/jack
[on the front of the module]

(5) **Case material:** Polyphenylene oxide
(flame retardant grade : UL94V-0 equiva-
lent)

(6) **Case color:** Case ; red
Terminal, base part ; black

(7) Protection

- Body: IP20 grade protection
(ventilation slits on the top and the bot-
tom of the body)
- Terminal: IP00 grade protection, terminal cover is
available as an option

9. Normal operating condition

(1) **Ambient temperature*:** -10 to 50°C

* "Ambient temperature" is the tempera-
ture underneath the controller inside
the equipment or the cabinet where
the controller is installed.

(2) **Ambient humidity:**

90% RH or less (non condensing)

(3) **Vibration:** 10 to 70Hz, 9.8m/s² (1G) or less

10. Transporting, storage condition (packing con- dition)

- (1) **Storage temperature:** -20 to 60°C
- (2) **Ambient humidity:** 90%RH or less (no condensing)
- (3) **Vibration:** 10 to 70Hz, 9.8m/s² (1G) or less
- (4) **Shock:** 294m/s² (30G) or less

11. Packing list

Temperature controller: 1 unit
Instruction manual: 1 copy

12. Loader software

(1) **Distribution medium:**

Free download from Fuji Electric website
([http://www.fujielectric.com/products/
instruments/](http://www.fujielectric.com/products/instruments/))

(2) **Recommended operating environment**

PC: DOS/V (PC-AT compatible)

OS: Windows XP (operation confirmed in
Japanese / English)

RAM: 256M bytes or more

Free space on the hardware: 500M bytes or more

Display resolution: 1024 × 768 or over

Serial interface: RS-232C 1 port
(without RS-232C, USB serial converter
cable required)

(3) **Connection with PUM**

Via loader interface on the front face of the module
(special cable available from Fuji is required) or via
RS-485

13. Certification

UL, C-UL

14. EU Directive Compliance

LVD (2014/35/EU)

EN 61010-1

EN 61010-2-030

EMC (2014/30/EU)

EN 61326-1 (Table 2)

EN 55011 (Group 1 Class A)

EN 61000-3-2 (Class A)

EN 61000-3-3

RoHS (2011/65/EU)

EN 50581

CODE SYMBOLS

[Event input/output module]

Digit	Description	1	2	3	4	5	6	7	8	9	10
4	< Module type > Event input/output module [Di 8 points / Do 8 points]	P	U	M	E	E					
5	< Output type > Transistor open collector (sink) output Relay contact output					C	R				
10	<Operation manual > Japanese English									A	B

[Accessories]

Digit	Description	1	2	3	4	5	6	7	8
6	RS-485 terminating resistance					A	0	1	
7	DIN rail mounting end plate					A	0	2	
8	Side connecting terminal cover (right & left 1 set)					A	0	3	
	Front face screw terminal cover					A	0	4	
	Loader connecting cable (RS-232C)					L	0	1	

[Table 1] Insulation block diagram

Power	Di1 to 4
Loader communication port	Di5 to 8
RS-485 communication port	Do1 to 4
	Do5 to 8

==== Functional insulation (1000V AC)
 —— Functional insulation (500V AC)

OUTLINE DIAGRAM (Unit : mm)

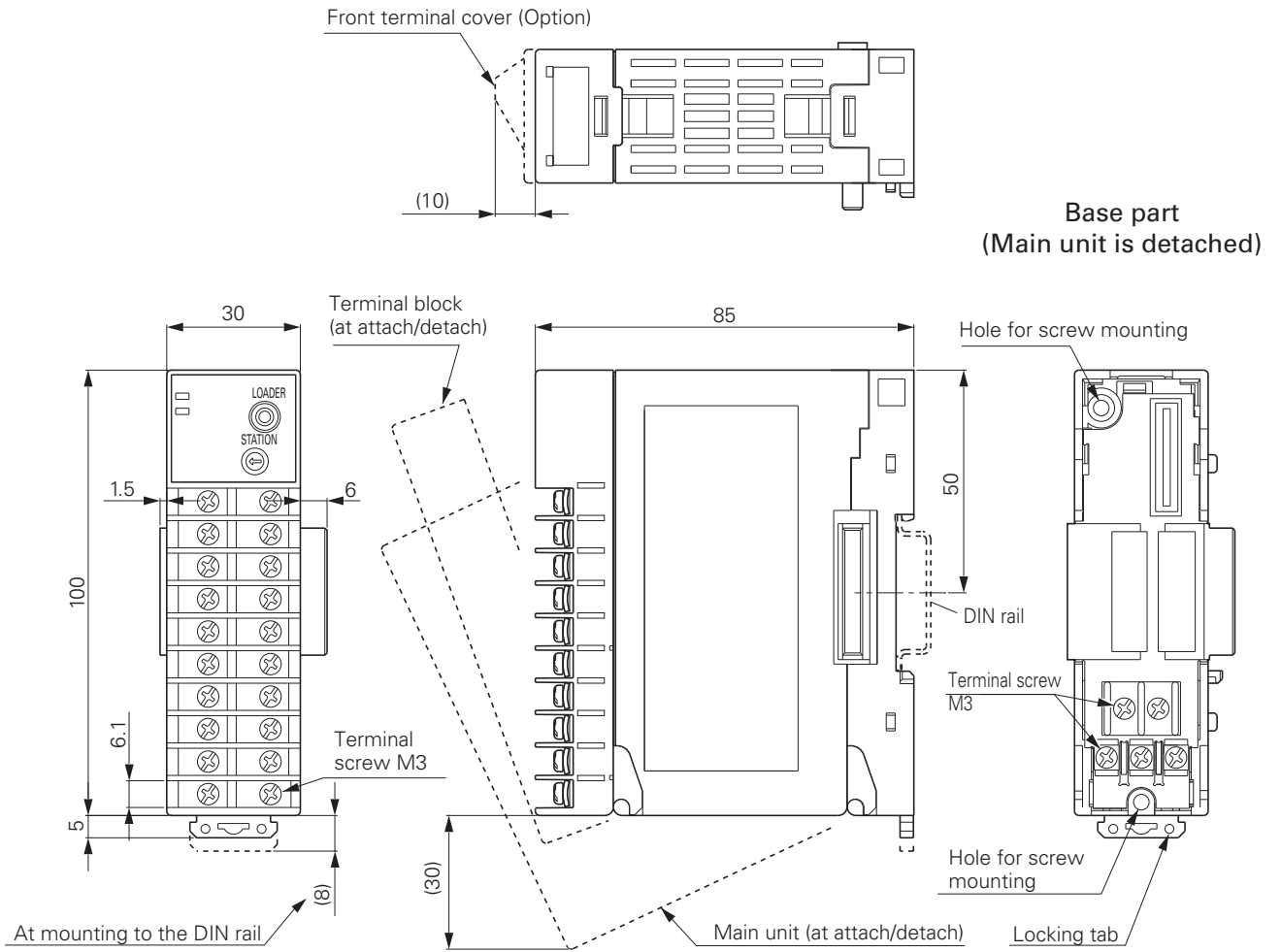

Dimensions for screw mounting

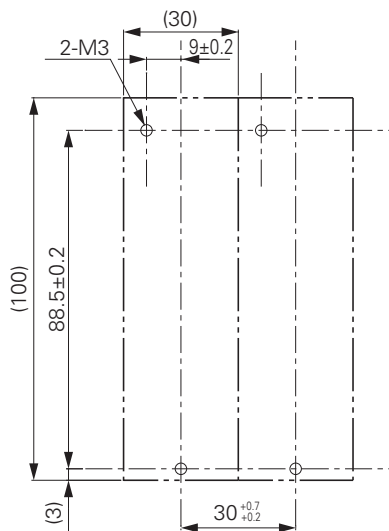

Notice at the installation

Please keep the distance of 30mm from this instrument to radiate.
[50mm is recommended]

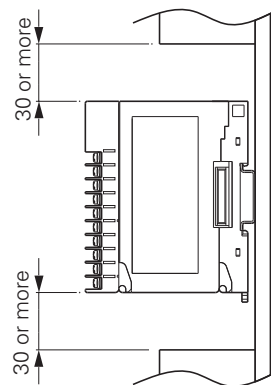

TERMINAL CONNECTION DIAGRAM

Loader interface plug (RS-232C)

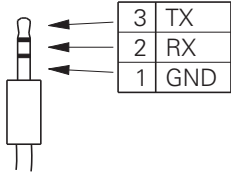

φ2.5 3-pole miniature plug

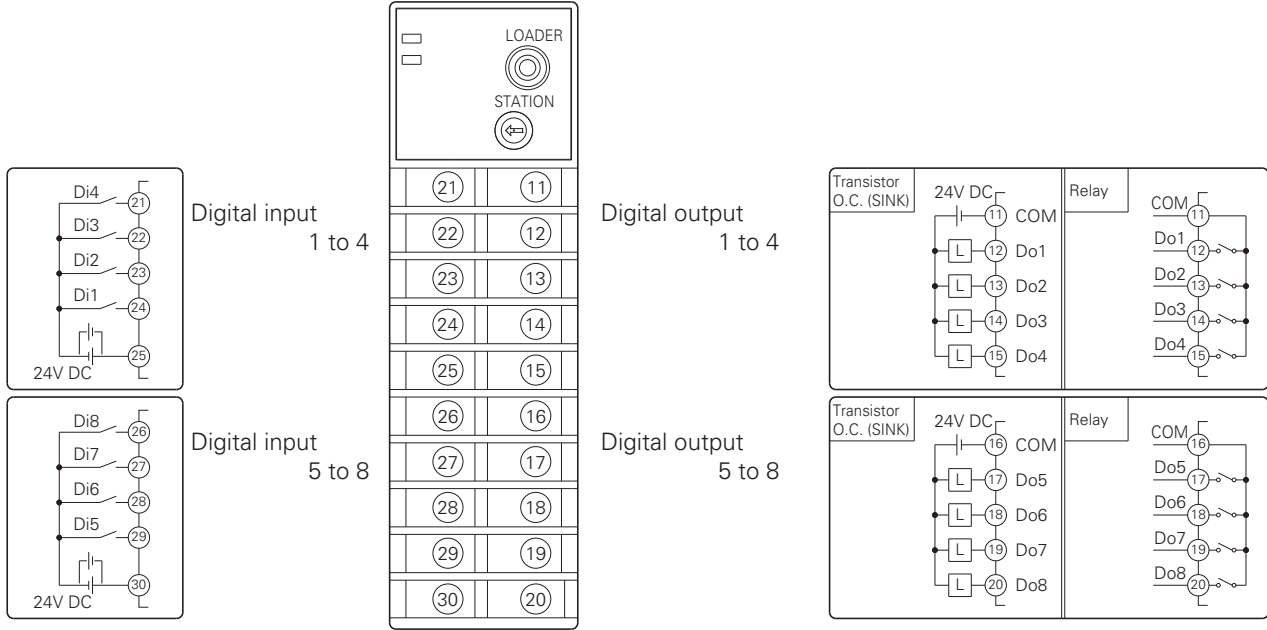

Base part

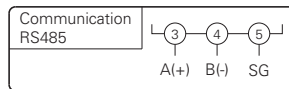
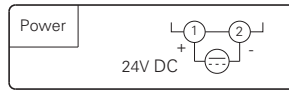
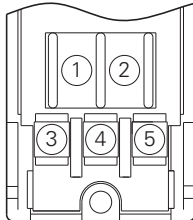

Operation parameter

Parameter (name)	Read/write date setting range	Factory default	Registor No.
Run/Standby switch	0: Run 1: Standby	0 (RUN)	40021
Digital input latch releases command	0: OFF 1: Release latch	0 (OFF)	40022
Digital output latch releases command	0: OFF 1: Release latch	0 (OFF)	40023

Communication parameter

Parameter (name)	Read/write date setting range	Factory default	Registor No.
RS-485 Parity setting	0: NONE 1: ODD 2: EVEN	0 (NONE)	40111
RS-485 Response interval time	0 to 25 (x20ms)	1	40113
RS-485 Communication permission	0: Read only 1: Read/Write	1 (R/W)	40114
RS-485 Communication speed	0: 9.6kbps 1: 19.2kbps 2: 38.4kbps 3: Forbidden 4: 115.2kbps	1 (9.6kbps)	40115
Enhanced communication module (PUMC) connection	0: PUMC not connected (RS485 Enable) 1: PUMC connected (RS485 Disable)	0	40116

Configuration parameter

Parameter (name)	Read/write date setting range	Factory default	Registor No.
FAULT output set value	0: HOLD 1: OFF	0 (HOLD)	40260
Standby output set value	0000 to FFFF	0000	40268
Standby mode setting	0: DI=Input value, DO=Standby output set value 1: DI=All OFF, DO=Standby output set value	0	40270
LED2 Lamp Allocation	0 to 2	1	40222

DI parameter

Parameter (name)	Read/write data setting range	Factory default	Register No.
D11 Input option	0 to 15 (bit data : 0000 to 1111) bit0 : LATCH bit1 : NOT bit2 : AND bit3 : OR	0 (bit data 0000)	40701
D11 Input logic operation AND	0000 to 00FF	0000	40703
D11 Input logic operation OR	0000 to 00FF	0000	40704
D12 Input option	0 to 15 (bit data : 0000 to 1111)	0 (bit data 0000)	40705
D12 Input logic operation AND	0000 to 00FF	0000	40707
D12 Input logic operation OR	0000 to 00FF	0000	40708
D13 Input option	0 to 15 (bit data : 0000 to 1111)	0 (bit data 0000)	40709
D13 Input logic operation AND	0000 to 00FF	0000	40711
D13 Input logic operation OR	0000 to 00FF	0000	40712
D14 Input option	0 to 15 (bit data : 0000 to 1111)	0 (bit data 0000)	40713
D14 Input logic operation AND	0000 to 00FF	0000	40715
D14 Input logic operation OR	0000 to 00FF	0000	40716
D15 Input option	0 to 15 (bit data : 0000 to 1111)	0 (bit data 0000)	40717
D15 Input logic operation AND	0000 to 00FF	0000	40719
D15 Input logic operation OR	0000 to 00FF	0000	40720
D16 Input option	0 to 15 (bit data : 0000 to 1111)	0 (bit data 0000)	40721
D16 Input logic operation AND	0000 to 00FF	0000	40723
D16 Input logic operation OR	0000 to 00FF	0000	40724
D17 Input option	0 to 15 (bit data : 0000 to 1111)	0 (bit data 0000)	40725
D17 Input logic operation AND	0000 to 00FF	0000	40727
D17 Input logic operation OR	0000 to 00FF	0000	40728
D18 Input option	0 to 15 (bit data : 0000 to 1111)	0 (bit data 0000)	40729
D18 Input logic operation AND	0000 to 00FF	0000	40731
D18 Input logic operation OR	0000 to 00FF	0000	40732

DO parameter

Parameter (name)	Read/write data setting range	Factory default	Registor No.
DO1 Output type	0: Event output 1: Control output	0 (Event output)	40401
DO1 Master module St. No.	0 to 255	0	40402
DO1 Master module Ch. No.	1 to 4	1	40403
DO1 BIT position	0000 to 00FF	0001	40404
DO1 Output option	0 to 15 (bit data : 0000 to 1111) bit0 : LATCH bit1 : NOT bit2 : AND bit3 : OR	0 (bit data 0000)	40405
DO1 Output logic operation AND	0000 to 00FF	0000	40407
DO1 Output logic operation OR	0000 to 00FF	0000	40408
DO1 Scaling base	-100.0 to 100.0%	0.0	40409
DO1 Scaling span	-100.0 to 100.0%	100.0	40410
DO1 Proportion cycle	1 to 120 sec.	30	40411
DO1 Lower limits	0.0 to 100.0%	0.0	40412
DO1 Upper limits	0.0 to 100.0%	100.0	40413
DO1 Limit type	0 to 3	0	40414
DO2 Output type	0: Event output 1: Control output	0 (Event output)	40415
DO2 Master module St. No.	0 to 255	0	40416
DO2 Master module Ch. No.	1 to 4	1	40417
DO2 BIT position	0000 to 00FF	0002	40418
DO2 Output option	0 to 15 (bit data : 0000 to 1111)	0 (bit data 0000)	40419
DO2 Output logic operation AND	0000 to 00FF	0000	40421
DO2 Output logic operation OR	0000 to 00FF	0000	40422
DO2 Scaling base	-100.0 to 100.0%	0.0	40423
DO2 Scaling span	-100.0 to 100.0%	100.0	40424
DO2 Proportion cycle	1 to 120 sec.	30	40425
DO2 Lower limits	0.0 to 100.0%	0	40426
DO2 Upper limits	0.0 to 100.0%	100.0	40427
DO2 Limit type	0 to 3	0	40428
DO3 Output type	0: Event output 1: Control output	0 (Event output)	40429
DO3 Master module St. No.	0 to 255	0	40430
DO3 Master module Ch. No.	1 to 4	1	40431
DO3 BIT position	0000 to 00FF	0004	40432
DO3 Output option	0 to 15 (bit data : 0000 to 1111)	0 (bit data 0000)	40433
DO3 Output logic operation AND	0000 to 00FF	0000	40435
DO3 Output logic operation OR	0000 to 00FF	0000	40436
DO3 Scaling base	-100.0 to 100.0%	0.0	40437
DO3 Scaling span	-100.0 to 100.0%	100.0	40438
DO3 Proportion cycle	1 to 120 sec.	30	40439
DO3 Lower limits	0.0 to 100.0%	0.0	40440
DO3 Upper limits	0.0 to 100.0%	100.0	40441
DO3 Limit type	0 to 3	0	40442
DO4 Output type	0: Event output 1: Control output	0 (Event output)	40443
DO4 Master module St. No.	0 to 255	0	40444
DO4 Master module Ch. No.	1 to 4	1	40445
DO4 BIT position	0000 to 00FF	0008	40446
DO4 Output option	0 to 15 (bit data : 0000 to 1111)	0 (bit data 0000)	40447
DO4 Output logic operation AND	0000 to 00FF	0000	40449
DO4 Output logic operation OR	0000 to 00FF	0000	40450
DO4 Scaling base	-100.0 to 100.0%	0.0	40451
DO4 Scaling span	-100.0 to 100.0%	100.0	40452
DO4 Proportion cycle	1 to 120 sec.	30	40453
DO4 Lower limits	0.0 to 100.0%	0.0	40454
DO4 Upper limits	0.0 to 100.0%	100.0	40455
DO4 Limit type	0 to 3	0	40456

DO parameter

Parameter (name)	Read/write data setting range	Factory default	Register No.
DO5 Output type	0: Event output 1: Control output	0 (Event output)	40457
DO5 Master module St. No.	0 to 255	0	40458
DO5 Master module Ch. No.	1 to 4	1	40459
DO5 BIT position	0000 to 00FF	0010	40460
DO5 Output option	0 to 15 (bit data : 0000 to 1111)	0 (bit data 0000)	40461
DO5 Output logic operation AND	0000 to 00FF	0000	40463
DO5 Output logic operation OR	0000 to 00FF	0000	40464
DO5 Scaling base	-100.0 to 100.0%	0.0	40465
DO5 Scaling span	-100.0 to 100.0%	100.0	40466
DO5 Proportion cycle	1 to 120 sec.	30	40467
DO5 Lower limits	0.0 to 100.0%	0.0	40468
DO5 Upper limits	0.0 to 100.0%	100.0	40469
DO5 Limit type	0 to 3	0	40470
DO6 Output type	0: Event output 1: Control output	0 (Event output)	40471
DO6 Master module St. No.	0 to 255	0	40472
DO6 Master module Ch. No.	1 to 4	1	40473
DO6 BIT position	0000 to 00FF	0000	40474
DO6 Output option	0 to 15 (bit data : 0000 to 1111)	0 (bit data 0000)	40475
DO6 Output logic operation AND	0000 to 00FF	0000	40477
DO6 Output logic operation OR	0000 to 00FF	0000	40478
DO6 Scaling base	-100.0 to 100.0%	0.0	40479
DO6 Scaling span	-100.0 to 100.0%	100.0	40480
DO6 Proportion cycle	1 to 120 sec.	30	40481
DO6 Lower limits	0.0 to 100.0%	0.0	40482
DO6 Upper limits	0.0 to 100.0%	100.0	40483
DO6 Limit type	0 to 3	0	40484
DO7 Output type	0: Event output 1: Control output	0 (Event output)	40485
DO7 Master module St. No.	0 to 255	0	40486
DO7 Master module Ch. No.	1 to 4	1	40487
DO7 BIT position	0000 to 00FF	0000	40488
DO7 Output option	0 to 15 (bit data : 0000 to 1111)	0 (bit data 0000)	40489
DO7 Output logic operation AND	0000 to 00FF	0000	40491
DO7 Output logic operation OR	0000 to 00FF	0000	40492
DO7 Scaling base	-100.0 to 100.0%	0.0	40493
DO7 Scaling span	-100.0 to 100.0%	100.0	40494
DO7 Proportion cycle	1 to 120 sec.	30	40495
DO7 Lower limits	0.0 to 100.0%	0.0	40496
DO7 Upper limits	0.0 to 100.0%	100.0	40497
DO7 Limit type	0 to 3	0	40498
DO8 Output type	0: Event output 1: Control output	0 (Event output)	40499
DO8 Master module St. No.	0 to 255	0	40500
DO8 Master module Ch. No.	1 to 4	1	40501
DO8 BIT position	0000 to 00FF	0000	40502
DO8 Output option	0 to 15 (bit data : 0000 to 1111)	0 (bit data 0000)	40503
DO8 Output logic operation AND	0000 to 00FF	0000	40505
DO8 Output logic operation OR	0000 to 00FF	0000	40506
DO8 Scaling base	-100.0 to 100.0%	0.0	40507
DO8 Scaling span	-100.0 to 100.0%	100.0	40508
DO8 Proportion cycle	1 to 120 sec.	30	40509
DO8 Lower limits	0.0 to 100.0%	0.0	40510
DO8 Upper limits	0.0 to 100.0%	100.0	40511
DO8 Limit type	0 to 3	0	40512

Internal DO data area parameter

Parameter (name)	Read/write date setting range	Factory default	Registor No.
Internal DO data area 1	Event output 1: ON 0: OFF	0	41001
Internal DO data area 2		0	41002
Internal DO data area 3		0	41003
Internal DO data area 4		0	41004
Internal DO data area 5	Control output 0.00 to 100.00	0	41005
Internal DO data area 6		0	41006
Internal DO data area 7		0	41007
Internal DO data area 8		0	41008
Internal DO data area 9		0	41009
Internal DO data area 10		0	41010
Internal DO data area 11		0	41011
Internal DO data area 12		0	41012
Internal DO data area 13		0	41013
Internal DO data area 14		0	41014
Internal DO data area 15		0	41015
Internal DO data area 16		0	41016

Monitor parameter

Parameter (name)	Read/write date setting range	Factory default	Registor No.
System FAULT status	0000 to FFFF	-	30064
DO calculated result monitor	0000 to FFFF	-	31002
DI calculated result monitor	0000 to FFFF	-	31001
DI terminal monitor	0000 to FFFF	-	31003

⚠ Caution on Safety

*Before using this product, be sure to read its instruction manual.

 Fuji Electric Co., Ltd.

Global Sales Section

Instrumentation & Sensors Planning Dept.

1, Fuji-machi, Hino-city, Tokyo 191-8502, Japan

<http://www.fujielectric.com>

Phone: +81-42-514-8930 Fax: +81-42-583-8275

<http://www.fujielectric.com/products/instruments/>