

PUMA/B is a control module, which forms the core of PUM series. Each control module, 30mm wide, is equipped with PID control function for maximum 4 channels, 8 points of CT input/output, and high-speed RS-485 port. By connecting with PUM event input/output modules, it realizes a compact and high-performance system.



FEATURES

I. High-level control functions for various applications

1. Process value input, control output:
max. 4 points (4 channels independent control)
(Process value input: Insulation between channel,
All input/output and power supply: Insulation)
2. CT input: max. 8 points
One unit can detect three phase heater break for 4 channels
3. High-speed sampling: 100msec
(Resistance bulb type and Thermocouple type is 200msec)
4. Input measurement accuracy: $\pm 0.3\%FS$
5. Types of control output can be selected by 2 channels
(Relay contact/SSR drive/current linear output)
6. Analog re-transmission output function can be assigned to current output
7. ON/OFF control, PID control Fuzzy PID control, and Heat/Cool control and Valve control

II. User-friendly structure and functions

1. Lateral connection : Max.16 units (64 channels) + event input/output module 16 units = total 32 units
Simple wiring for power supply and communication
2. Detachable structure: Terminal block, main unit, and the base part
→ Easy wiring with detachable terminal block
→ Main units exchangeable without re-wiring
3. Status LED for each control channel
→ Easy to detect error channel
4. Smart loader communication: Connect one module and all connected modules are able to communicate using a loader software.

III. Large scale system using high speed RS-485

1. Modbus RTU protocol for large volume communication
2. High-speed communication: Maximum 115.2kbps
3. Highly-efficient communication: Parameters dispersed on the address map are re-allocated to contiguous address

IV. Various functions to realize high-performance system

1. Alarm function (output from event I/O module or the control output which is not used)
2. Power distribution function (with event I/O module):
Power ratio can be set to multiple point output by input/control calculation value of one channel

3. Operation mode control by digital input (with event I/O module): Run/Standby, etc.
4. Remote operation using input, and re-transmission output using output of connected analog input/output module (other stations)

SYSTEM SPECIFICATION

1. **Product type:** Multi-loop module type temperature controller
2. **Module types**
 - 1) Analog module: 16 units maximum
 - Control module (4 loops per unit)
 - Analog input/output module (4 points each per unit)
Analog input module (4 points per unit)
Analog output module (4 points per unit)
 - 2) Digital module: 16 units maximum
Event input/output module (8 points each per unit)
 - 3) Communication module: 1 unit
3. **Connecting method:**
Lateral connecting with connectors
- For power supply and RS-485 communication, any one of connected modules is required to be connected.
4. **No. of loop, input/output**
 - 1) Control loop: Max. 64
 - 2) No.of input/output: DI 128 points / DO 128 points

MODULE SPECIFICATION

1. General specification

- (1) **Power supply:** 24V DC $\pm 10\%$
- (2) **Power consumption:** Max. 3.2 W (135 mA)
[when 24V DC is applied]
- (3) **Insulation resistance:** 20M Ω or more (500V DC)

(4) Withstand voltage:

Power supply ↔ all terminals	1000V AC 1 min.
Relay contact ↔ all terminals	1500V AC 1 min.
Others	500V AC 1 min.

2. Input

2.1 Process value input

- (1) **No. of input:** 2 or 4 points (1 point/channel)
- (2) **Input setting:** Input code selection
- (3) **Input signal:** See table 1
Select from group I or II depending on the model code.
(setting can be done by channel within group)
[Group I] a) Thermocouple
b) Resistance bulb (3 wire)
[Group II] c) DC voltage, current
- (4) **Measurement range and input type:** See table 1
- (5) **Measurement accuracy (Ta = 23°C)**
 - a) Thermocouple: ±0.3%FS ±1digit ±1°C
or ±3°C whichever is greater
 - *Unless;
 - B thermocouple 0 to 500°C: ±5%FS ±1digit ±1°C
 - R thermocouple 0 to 500°C: ±1%FS ±1digit ±1°C
 - T thermocouple -200 to 0°C: ±0.5%FS ±1digit ±1°C
 - b) Resistance bulb input: ±0.3%FS ±1digit or ±1°C
whichever is greater
 - c) Voltage / Current input: ±0.3%FS ±1digit
- (6) **Resolution:** See table 1
- (7) **Temperature fluctuation:** ±0.3%FS/10°C
- (8) **Input sampling cycle:** 100msec (Resistance bulb type and Thermocouple type is 200msec)
- (9) **Input impedance**
 - Thermocouple: 1MΩ or more
 - Current input: 250Ω
 - Voltage input: approx. 1MΩ
- (10) **Influence of signal source resistance**
 - Thermocouple: ±0.3%FS±1digit / 100Ω
 - Voltage input: ±0.3%FS±1digit / 500Ω
- (11) **Allowable wiring resistance**
 - Resistance bulb: 10Ω or less (per wire)
- (12) **Allowable input voltage**
 - DC voltage input: within ±15V
 - Current input: within ±25mA
 - Thermocouple/resistance bulb: within ±5V
- (13) **Noise rejection ratio**
 - Normal mode: 30dB or more (50/60Hz)
 - Common mode: 120dB or more (50/60Hz)
between process value input and earth, power supply, output 220V AC, 50/60Hz
- (14) **Input compensation**
 - a) User adjustment: zero point, span point ±50%FS
 - b) PV shift: ±10%FS
 - c) First order lag filter: 0.0 to 120.0 sec.
- (15) **Overrange, underrange:**
 - Out of range of -5 to 105%FS
 - (Accuracy cannot be ensured for -5 to 0, 100 to 105%FS)
- (16) **Insulation:** Functional insulation between channels, and with any other input/output

2.2 Heater break detector (CT) input

- (1) **No. of input:** 4 or 8 points (2 points/loop)
- (2) **Input type:** Single-phase type CT /point
1 to 30A: CTL-6-S-H
20 to 50A: CTL-12-S36-8

(3) Current detection accuracy:

Input value ±10% or ±2A, whichever is greater

(4) Time required for detection

- ON detection: 800ms or more
- OFF detection: 2 sec. or more

(5) Connection method:

Connector for heater break detector
[on the front of module]

(6) Insulation:

No insulation between channels
No insulation with communication port (RS-485, loader)
Functional insulation with any other input/output

3. Output

3.1 Control output

- (1) **No. of output:** 2 points (1 point/loop) or 4 points (2 points/loop)
- (2) **Control output behaviour:** Heat (reverse action) or cool (direct action), or heat/cool (control output 2 points/loop required), Valve (control output 2 points/loop required)
- (3) **Output type:** Selected from a) to d) (by 2 channels)
 - a) Relay contact output
 - Proportional cycle: 1 to 150 sec.
 - Contact structure: SPST contact
 - Contact capacity: 220V AC/30V DC, 3A (resistance load) 220V AC/30V DC, 1A (inductive load)
 - Min. switching current: 100mA (24V DC)
 - Mechanical life: 20,000,000 switching or more (100/min.)
 - Electric life: 100,000 switching or more (rated load)
 - Insulation: Basic insulation with any other input/output
 - b) SSR/SSC drive output
 - Proportional cycle: 1 to 150 sec.
 - Minimum resolution: 5ms
 - ON voltage: 10V DC (8 to 12V DC)
 - OFF voltage: 0.5V DC or less
 - Max. current: 20mA DC (per point)
 - Load resistance: 500Ω or more
 - Insulation: No insulation with any other output (excluding relay output)
Functional insulation with others than those above
 - c) Current output (4 to 20mA DC, 0 to 20mA DC)
 - Actual output range: 0mA to 20.6mA DC
 - Accuracy: ±0.3%FS
(less than 1mA : ±5%FS)
 - Linearity: ±0.3%FS
(less than 1mA : ±5%FS)
 - Resolution: 5,000 or more
 - Ripple current: P-P 0.3mA or less
 - Load resistance: 300Ω or less
 - Insulation: No insulation with any other output (excluding relay output)
Functional insulation with others than those above

(4) Optional functions:

Output limit, Soft start, power distribution, Output shutdown, output scaling (for current output only)

3.2 Analog re-transmission output

- (1) No. of output: 2 points (OUT3, OUT4 applied)
- (2) Output type: Current output (4 to 20mA DC, 0 to 20mA DC)
- (3) Option: Output scaling

4. Communication function

4.1 RS-485 interface

- (1) Communication standards: RS-485 compatible
- (2) No. of port: 1 port
- (3) Communication, synchro method:
Two-wire, half-duplex, asynchronous cycle
- (4) Communication speed: 9.6k, 19.2k, 38.4k, 115.2kbps
- (5) Communication distance: 1km (38.4kbps or less),
250m (115.2kbps)
- (6) Recommended cable: KPEV-SB 0.5sq-equivalent
- (7) No. of connectable units:
33 units (master and slave)
(32 units if any modules other than PUM series are included in slaves.)
- (8) Data format: Data bit; 8, parity; even / odd / none
- (9) Protocol: Modbus RTU compatible
- (10) Insulation: No insulation with loader communication port, CT input
Functional insulation with any other input/output

4.2 Loader communication (RS-232C) interface

- (1) Communication standards: RS-232C compatible
- (2) No. of port: 1 port
- (3) Communication, synchro method:
Half-duplex, asynchronous cycle
- (4) Communication speed: 19.2kbps (fixed)
- (5) Data format: Data bit 8, no parity
- (6) Protocol: Modbus RTU compatible
- (7) Connection method:
2.5 diameter mini-plug/jack
[on the front of the module]
(Common cable with PXG, PXH)
- (8) Insulation: No insulation with RS-485, CT input
Functional insulation with any other input/output

5. Control functions

5.1 Control methods

- (1) PID control (including FUZZY PID control)
 - PID constant: Set by auto tuning
- (2) PID 2 (Heat/cool) control (including FUZZY PID control)
 - PID constant: Set by auto tuning
- (3) PID Valve (OPEN CLOSE) control (including FUZZY PID control)
 - PID constant: Set by auto tuning

5.2 Control parameter

- Proportional band (P):
0.0 to 999.9%, P=0: 2 position control ON
- Integration time (I):
0 sec to 3200 sec. I=0: Integration OFF
- Derivation time (D):
0.0 to 999.9 sec. D=0: Derivation OFF
- Control cycle: 100msec (Resistance bulb type and Thermocouple type is 200msec)

5.3 Control mode

- (1) Mode type: Auto / Manual / Remote
- (2) Mode switching:
Auto ↔ Manual: balanceless / bumpless transfer
Auto/Manual ↔ Remote: balance/bumpless transfer
Auto/Manual ↔ Remote: balance/bumpless transfer

5.4 Digital input function

- (1) Operation control by digital input:
Run/Standby switch, Auto/Manual switch,
Local/Remote switch, Start auto tuning,
Ramp SV ON/OFF, Ramp SV HOLD, DO
latch release, Start timer, Output shut-
down
- (2) Input method: Input using event input/output module

6. Alarm function

6.1 Alarm function

- (1) No. of alarm set- points: 5 points / control channel
- (2) Alarm type: PV value(Lower/upper limit, absolute/de-
viation value, range)
Loop burnout alarm, Error alarm, etc.
(Non-excitation, delay, latch, timer func-
tion also available)
- (3) Alarm output: Data output via communication or output
from event input / output module

6.2 Heater break alarm

- (1) No. of alarm set-points:
4 or 8 points (2 points/control channel)
- (2) Alarm type: Detect when output ON (break detec-
tion)
Detect when output OFF (leakage current
detection)
(setting can be done separately by point)
- (3) Heater current alarm
Detectable current range: 2A to 50A
Detected current resolution: 0.1A
Setting resolution: 0.1A
Operation dead band: 0.0 to 50.0A
- (4) Alarm output: Data output via communication or output
from event input/output module

Current output model cannot output the HB alarm.
Current output model can perform the CT monitor only.

7 Display, configuration

7.1 Display

- (1) Display: Status display LED
(2 colors × 6 points)
- (2) Display contents:
RUN/FAULT, RS-485 TX/RX, OUT/ERR by
loop (4 loops) (Functions are assigned to
LED of each channel)

7.2 Setting device

- (1) Setting device: Rotary SW × 1
- (2) Set contents: RS-485 Station No.
(Station No.= setting value + 1)

8. Power outage

- (1) Impact of power outage:
Outage of 2ms or less ; no impact
- (2) Operation after power outage:
Start from the first step (cold start)
- (3) Memory backup:
Nonvolatile memory (EEPROM)
No. of update ; 100,000

9. Self diagnosis

- Diagnosis method:
Program error monitoring by watch dog timer

10. Structure

- (1) Installation method:
DIN rail mounting or mounting with M3 screws inside a cabinet
- (2) Dimensions: 30 (W) × 100 (H) × 85 (D) mm
(excluding terminal cover and projected part)
- (3) Weight: Approx. 200 g
- (4) External terminal
 - Process value input/control output:
Detachable terminal block
(M3 screw × 20 terminals)
 - Power supply connection:
Terminal block on the base part
(M3 screw × 2 terminals)
Power is supplied via side connectors in case of lateral connecting. (Max. 33 units)
 - RS-485 communication connection:
Terminal block on the base part
(M3 screw × 3 terminals)
RS-485 communication is connected via side connectors in case of lateral connecting.
 - CT input: Special connectors (8 pin × 2 pcs.)
[on the front of the module]
 - Loader communication port:
2.5 diameter mini-plug/jack
[on the front of the module]
- (5) Case material: Polyphenylene oxide
(flame retardant grade : UL94V-0 equivalent)
- (6) Case color: Case ; red
Terminal, base part ; black
- (7) Protection
 - Body: IP20 grade protection
(ventilation slits on the top and the bottom of the body)
 - Terminal: IP00 grade protection, terminal cover is available as an option

11. Normal operating condition

- (1) Ambient temperature*: -10 to 50°C
* "Ambient temperature" is the temperature underneath the controller inside the equipment or the cabinet where the controller is installed.
- (2) Ambient humidity:
90% RH or less (non condensing)
- (3) Vibration: 10 to 70Hz, 9.8m/s² (1G) or less
- (4) Warmup time: 30 min. or more

12. Transporting, storage condition (packing condition)

- (1) Storage temperature: -20 to 60°C
- (2) Ambient humidity: 90%RH or less (no condensing)
- (3) Vibration: 10 to 70Hz, 9.8m/s² (1G) or less
- (4) Shock: 294m/s² (30G) or less

13. Packing list

- Temperature controller: 1unit
- Instruction manual: 1 copy
- 250Ω resistance: 0 or 2 or 4 pcs.
(For no. points of voltage/current input selected)

14. Loader software

- (1) Distribution medium:
Free download from Fuji Electric website
(<http://www.fujielectric.com/products/instruments/>)
- (2) Recommended operating environment
 - PC: DOS/V (PC-AT compatible)
 - OS: Windows XP (operation confirmed in Japanese / English)
Windows 7 corresponds by Ver.2.0.0.
 - RAM: 256M bytes or more
 - Free space on the hardware: 500M bytes or more
 - Display resolution: 1024 × 768 or over
 - Serial interface: RS-232C 1 port
(without RS-232C, USB serial converter cable required)
- (3) Connection with PUM
Via loader interface on the front face of the module
(special cable available from Fuji is required)

15. Certification

UL, C-UL

16. EU Directive Compliance

- LVD (2014/35/EU)
 - EN 61010-1
 - EN 61010-2-030
- EMC (2014/30/EU)
 - EN 61326-1 (Table 2)
 - EN 55011 (Group 1 Class A)
 - EN 61000-3-2 (Class A)
 - EN 61000-3-3
- RoHS (2011/65/EU)
 - EN 50581

CODE SYMBOLS

[Control module (4 channels)]

Digit	Description	1	2	3	4	5	6	7	8	9	10	11	12	13
4	< Module type > 4ch control module	P	U	M	A				1	-	0		0	0
5	< Input type > Thermocouple / resistance bulb [all channels] Voltage / current [all channels] Thermocouple / resistance bulb [ch 1, 2], voltage / current [ch3, 4]				A									
6	< OUT1, 2 output type > Relay output SSR drive output Current output					T	A							
7	< OUT3, 4 output type > Relay output SSR drive output Current output					A	C	E						
10	< Operation Manual > Japanese English											A	B	
11	< Option 1 > Not fitted CT input (8 points) *												Y	C

* Current output model cannot output the HB alarm.
Current output model can perform the CT monitor only.

[Control module (2 channels)]

Digit	Description	1	2	3	4	5	6	7	8	9	10	11	12	13
4	< Module type > 2ch control module	P	U	M	B				1	-	0		0	0
5	< Input type > Thermocouple / resistance bulb [all channels] Voltage / current [all channels]				B									
6	< OUT1, 2 output type > Relay output SSR drive output Current output					T	A							
7	< OUT3, 4 output type > Not fitted Relay output SSR drive output Current output					A	C	E						
10	< Operation Manual > Japanese English											A	B	
11	< Option 1 > Not fitted CT input (4 points) *												Y	C

* Current output model cannot output the HB alarm.
Current output model can perform the CT monitor only.

[Accessories]

Digit	Description	1	2	3	4	5	6	7	8
6	RS-485 terminating resistance	P	U	M	Z	*			
7	DIN rail mounting end plate						A	0	1
8	Side conneting terminal cover (right & left 1 set)						A	0	2
	Front face screw terminal cover						A	0	3
	Loader connecting cable (RS-232C)						A	0	4
	CT input terminal cable (for 4 points) [l=1m]						L	0	1
	CT input terminal cable (for 4 points) [l=3m]						C	0	1
	CT input terminal cable (for 4 points) [l=5m]						C	0	3
	CT for 1 to 30A (CTL-6-S-H)						C	0	5
	CT for 2 to 50A (CTL-12-S36-8)						C	T	1
							C	T	2

[Table 1] Input type and standard nput range

Input type	Input code	Measurement range		Min. measurement unit		
		[°C]	[°F]	[°C]	[°F]	
Resistance bulb (IEC)	Pt100Ω	2	0 to 150	32 to 302	0.1	0.1
		3	-150 to 300	-238 to 572	0.1	0.1
		4	-150 to 850	-238 to 1562	0.1	1
Thermocouple	J	5	0 to 400	32 to 752	0.1	0.1
		6	0 to 800	32 to 1472	0.1	1
	K	7	0 to 400	32 to 752	0.1	0.1
		8	0 to 800	32 to 1472	0.1	1
		9	0 to 1200	32 to 2192	1	1
	R	10	0 to 1600	32 to 2912	1	1
	B	11	0 to 1800	32 to 3272	1	1
	S	12	0 to 1600	32 to 2912	1	1
	T	13	-199 to 400	-326 to 752	0.1	1
	E	14	-199 to 800	-326 to 1472	0.1	1
	N	18	0 to 1300	32 to 2372	1	1
	PL-II	19	0 to 1300	32 to 2372	1	1
DC voltage *	DC0-5V	21	-1999 to 9999 (scaling range)		-	-
	DC1-5V	22				
	DC0-10V	23				
	DC2-10V	24				
	DC±5V	25				
	DC±10V	26				
No input	-	30	-	-	-	-
Resistance bulb (IEC)	Pt100Ω	31	-200 to 850	-328 to 1562	1	1
		32	-200 to 800	-328 to 1472	0.1	1
Thermocouple	J	35	-200 to 850	-328 to 1562	1	1
		36	-150 to 850	-328 to 1562	0.1	1
		37	-200 to 800	-328 to 1472	0.1	1
	K	38	-200 to 850	-328 to 1562	1	1
		39	-150 to 850	-328 to 1562	0.1	1
		40	-200 to 800	-328 to 1472	0.1	1

* In case of currenet input, attach I/V unit which comes with the controller to the voltage input terminal.

[Table 2] Insulation block diagram

Power	PV1
Loader communication port	PV2
RS-485 communication port	PV3
CT Input (CT1A, B - CT4A,B)	PV4
OUT1 (relay contact output)	OUT1 (SSR drive, current)
OUT2 (relay contact output)	OUT2 (SSR drive, current)
OUT3 (relay contact output)	OUT3 (SSR drive, current)
OUT4 (relay contact output)	OUT4 (SSR drive, current)

- Basic insulation (1500V AC)
- Functional insulation (1000V AC)
- Functional insulation (500V AC)

OUTLINE DIAGRAM (Unit : mm)

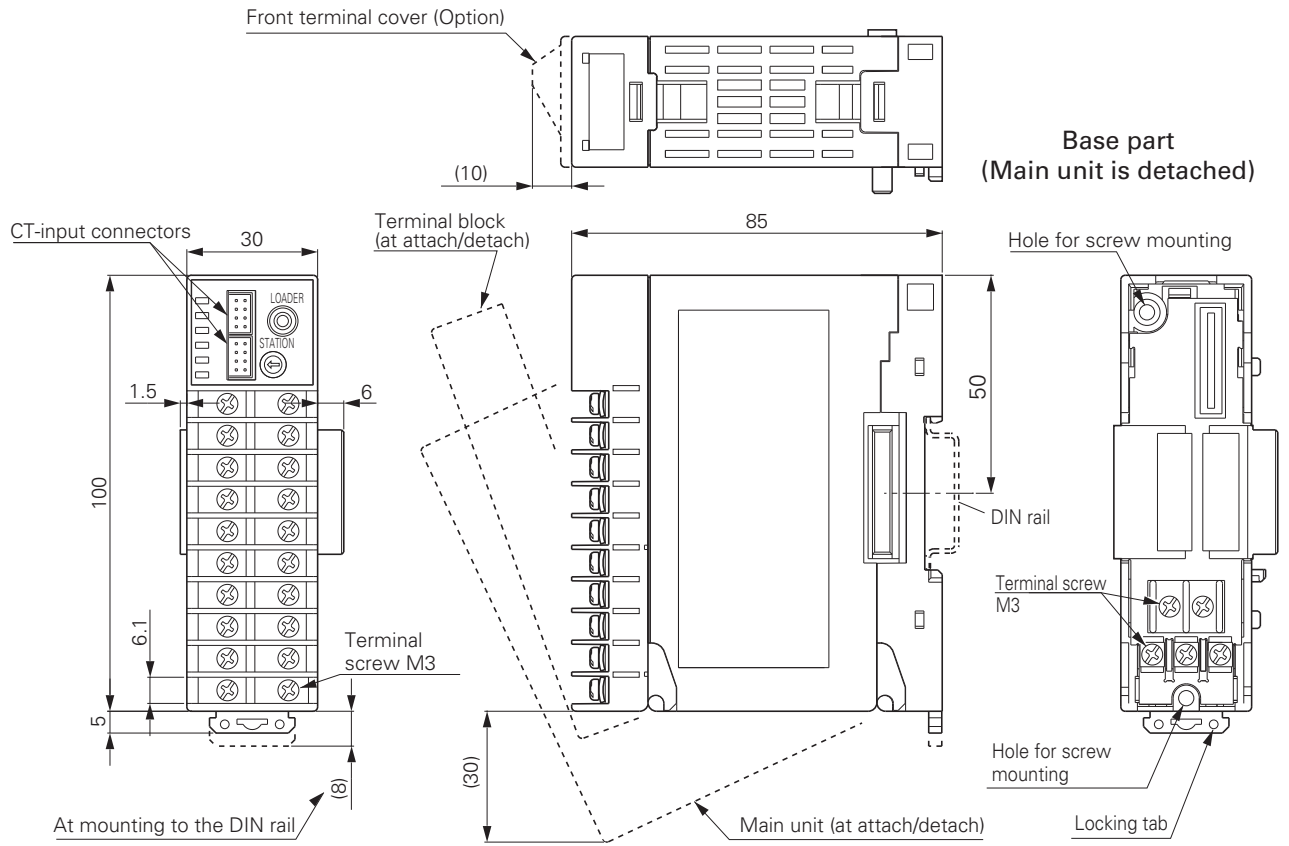

Dimensions for screw mounting

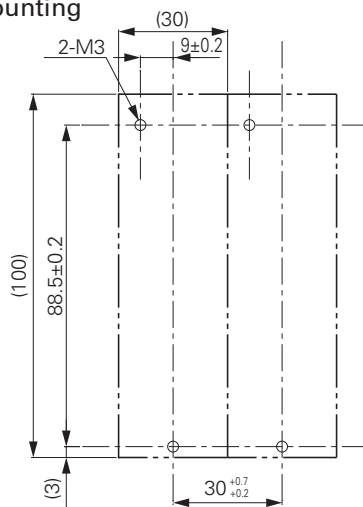

Notice at the installation

Please keep the distance of 30mm from this instrument to radiate.
[50mm is recommended]

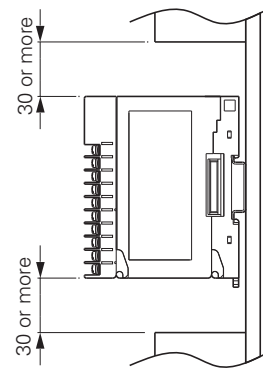

Heater current detector (CT)

Specification : 1 to 30 A
Type : CTL-6-S-H

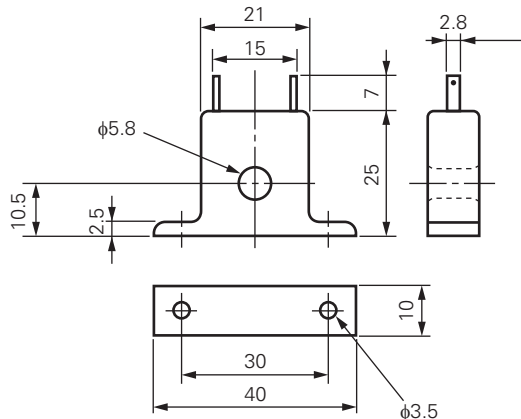

Specification : 20 to 50 A
Type : CTL-12-S36-8

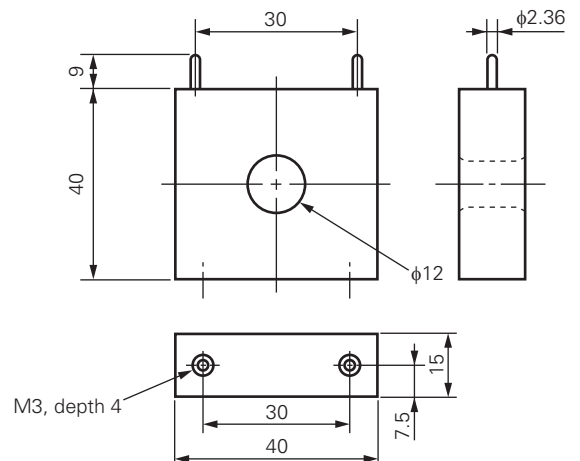

TERMINAL CONNECTION DIAGRAM

CT input connector

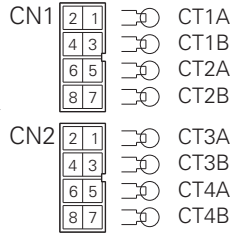

* No. 2, 4, 6 and 8 pins of CN1 and CN2 are connected in the instruments.

* CN2 is not available for model PUMB.

CT input cable connection table

Pin No.	Cable distinction color	
	Cover color	Dot color
1	Yellow	Red
2		Black
3	White	Red
4		Black
5	Light-gray	Red
6		Black
7	Orange	Red
8		Black

Loader interface plug (RS-232C)

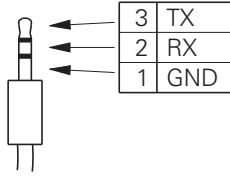

φ2.5 3-pole miniature plug

* Input 3 and Input 4 are not available for model PUMB.

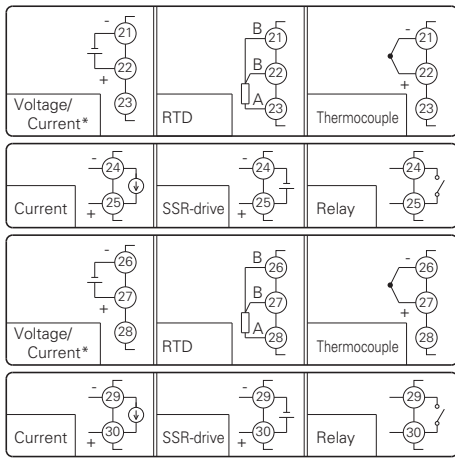

* In case of current input, attach I/V unit which comes with the controller to the voltage input terminal.

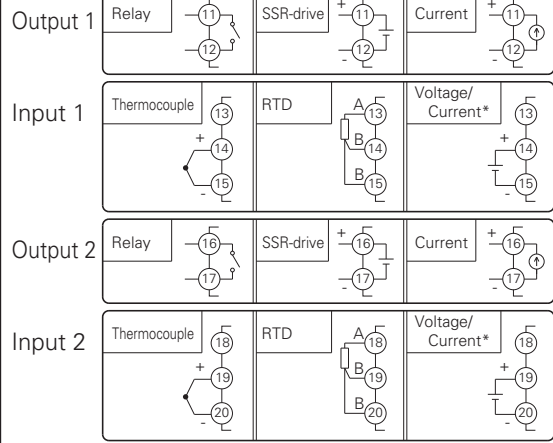
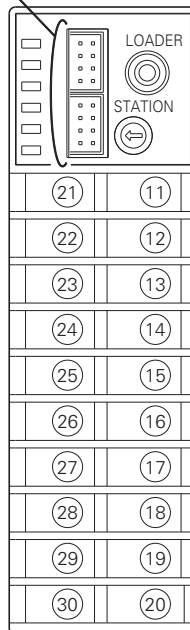

* In case of current input, attach I/V unit which comes with the controller to the voltage input terminal.

Base part

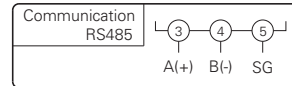
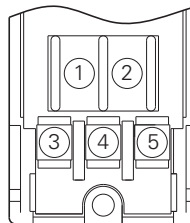

⚠ Caution on Safety

*Before using this product, be sure to read its instruction manual.

F Fuji Electric Co., Ltd.

Global Sales Section
 Instrumentation & Sensors Planning Dept.
 1, Fuji-machi, Hino-city, Tokyo 191-8502, Japan
<http://www.fujielectric.com>
 Phone: +81-42-514-8930 Fax: +81-42-583-8275
<http://www.fujielectric.com/products/instruments/>