

FRENIC - Ace Quick Reference Guide

FRENIC - Ace Control Wiring

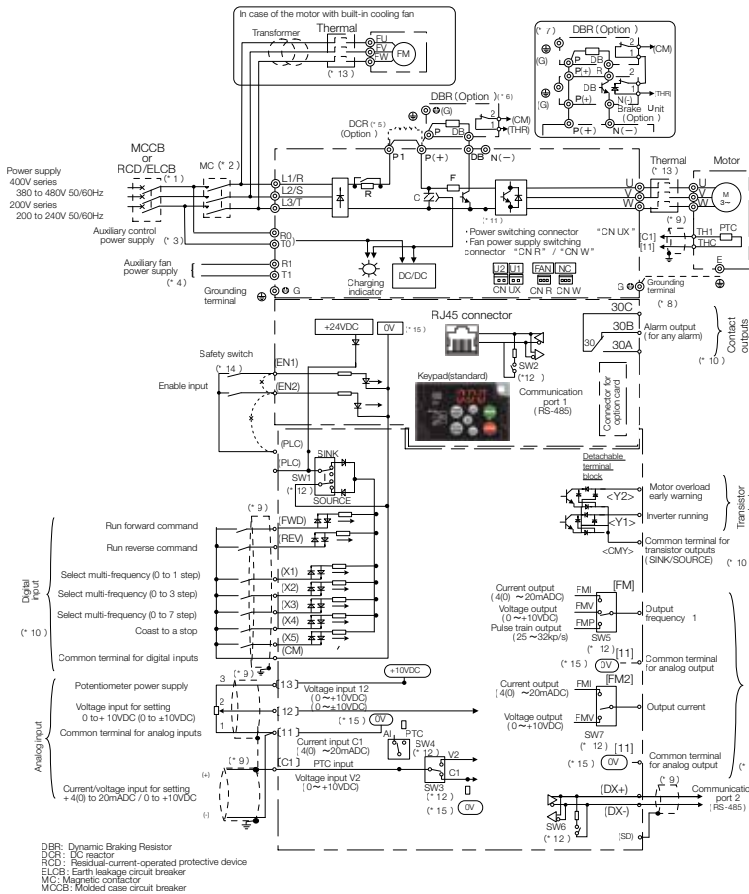

- *1 Install a recommended molded case circuit breaker (MCCB) or residual-current-operated protective device (RCD)/earth leakage circuit breaker (ELCB) (with overcurrent protection function) in the primary circuit of the inverter to protect wiring. Ensure that the circuit breaker capacity is equivalent to or lower than the recommended capacity.
- *2 Install a magnetic contactor (MC) for each inverter to separate the inverter from the power supply, apart from the MCCB or RCD/ELCB, when necessary. Connect a surge absorber in parallel when installing a coil such as the MC or solenoid near the inverter.
- *3 The R0 and T0 terminals are provided for inverters of type 0059 or above(460V class) and type 0088 or above(230V class). To retain an alarm output signal ALM issued on inverter's programmable output terminals by the protective function or to keep the keypad alive even if the main power has shut down, connect these terminals to the power supply lines. Even if without connecting the power supply to these terminals, the inverter can run as long as connecting the power supply to the terminals L1/R, L2/S, L3/T.
- *4 Normally no need to be connected. Use these terminals when the inverter is equipped with a high power-factor, regenerative PWM converter (RHC series). (Type 0203 or above/460V only)
- *5 When connecting an optional DC reactor (DCR), remove the jumper bar from the terminals P1 and P(+). For types 0139 (ND spec.), 0168 (HD/ND spec.) and 0203 or bigger capacity types, it is required to connect the DCR (460V only). Use a DCR when the capacity of the power supply transformer exceeds 500 kVA and is 10 times or more the inverter rated capacity, or when there are thyristor-driven loads in the same power supply line.
- *6 Inverters of type 0072 or below(460V class) and type 0115 or below(230V class) have a built-in braking chopper between the terminals P(+) and DB.
- *7 For inverters of type 0085 or above (460V class), need to use a braking unit to connect the braking resistor in order to upgrade the braking capability of inverters. Be sure to connect the braking unit (option) to terminals P(+) and N(-). Auxiliary terminals [1] and [2] have polarity. Be sure to connect as this figure.
- *8 A grounding terminal for a motor. Use this terminal if needed.
- *9 For control signal wires, use twisted or shielded-twisted wires. When using shielded-twisted wires, connect the shield of them to the common terminals of the control circuit. To prevent malfunction due to noise, keep the control circuit wiring away from the main circuit wiring as far as possible (recommended: 10 cm(3.9 inches) or more). Never install them in the same wire duct. When crossing the control circuit wiring with the main circuit wiring, set them at right angles.
- *10 The connection diagram shows factory default functions assigned to digital input terminals [X1] to [X5], [FWD] and [REV], transistor output terminals [Y1] and [Y2], and monitor contact output terminals [FM].
- *11 The power switching connectors (CN UX) and the fan power supply switching connectors (CN R and CN W) are for type 0203(460 V class) or above.
- *12 Slide switches on the control printed circuit board (control PCB). Use these switches to customize the inverter operations.
- *13 Use auxiliary contacts of the thermal relay (manually restorable) to trip the molded case circuit breaker (MCCB) or magnetic contactor (MC).
- *14 When using the Enable input function, be sure to remove the jumper wire from terminals [EN1],[EN2] and [PLC].
- *15 and are separated and insulated

Control Card Terminals

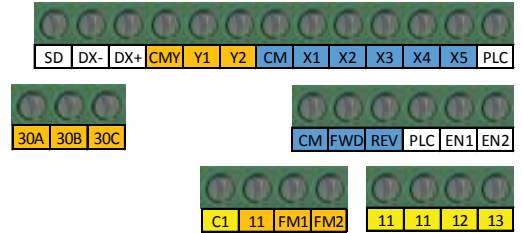

Orange = Outputs, Yellow = Analog Inputs, Blue = Digital Inputs

- FWD, Rev, plus 5 Digital inputs. Configurable for Source or Sink.

Item	Min.	Max.
Operating Voltage (Sink)	On level	0V
	Off level	22V
Operating Voltage (Source)	On level	22V
	Off level	0V

- 0-10VDC analog input.
- 4-20mA, 0-20mA or 0-10VDC analog input.
- 2 Transistor outputs.

Item	Max.
Operating Voltage (Sink)	2v
Off level	22V

Maximum Current at on 50mA

- Form C contact relay
 - o (250VAC 0.3A, cos ϕ =0.3), (48VDC, .5A).
- 1 0-10VDC, 4-20mA, 0-20mA or 25-32kp/s analog output.
- 1 0-10VDC, 4-20mA or 0-20mA analog output.
- 24VDC max 100mA DC output power.
- 10VDC output power for potentiometer.
- 2 Source only, safe torque off Enable Inputs.
- RS-485 wire terminals.

FRENIC-Ace (E2) Keypad

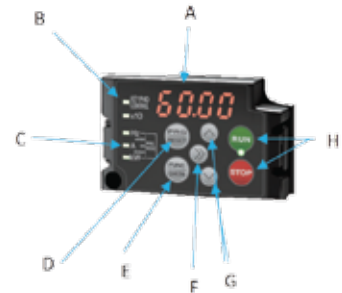

- A. LED Display
- B. Remote/Local Indicator
- C. Monitoring Display Indicator
- D. Program Reset Key
- E. Function Data Key
- F. Shift Key
- G. Menu Navigation Keys
- H. Local Mode Control Operators

First Power ON.

Upon powering the drive on for the first time you must set the region in Menu **8 dES**, for Americas by setting the value to **AMEr**. After initial start-up you may change the region by setting the value of H101. See page 4-4 of FRENIC-ACE Instructional Manual INR-SI47-1733f-E for more details.

Changing the regional from default value **AS rA** to **AMEr** requires pressing and holding **STOP** key while pressing **↵**

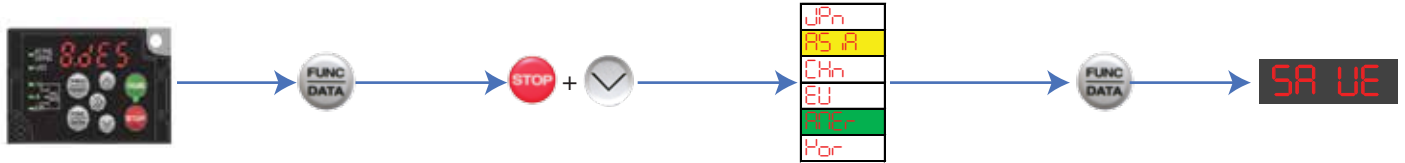

Quick Start Menus

1.F	Fundamental Functions
1.E	Extension Terminal Functions
1.C	Control Functions of Frequency
1.P	Motor 1 Parameters
1.H	High Performance Functions
1.H1	High Performance Functions
1.A	Motor 2 Functions
1.J	Application Functions
1.J1	PID Functions
1.d	Application Functions 2
1.U	Customizable Logic
1.U1	Customizable Logic
1.Y	Link Functions
1.k	Keypad Functions

2.	rEP (Data Check)
	Displays function codes that have been changed from factory default

3.	oPE (Operations Monitor)
3_00	Output frequency Before Slip
3_01	Output frequency After Slip
3_02	Output Current
3_03	Output Voltage
3_04	Calculated Torque
3_05	Reference Frequency
3_06	Rotation Direction
3_07	Running Status
3_08	Motor Speed r/min
3_09	Load Shaft speed
3_10	PID SV
3_11	PID PV
3_12	Torque Limit Value A
3_13	Torque Limit Value B
3_14	Ratio Setting
3_15	Line Speed r/min

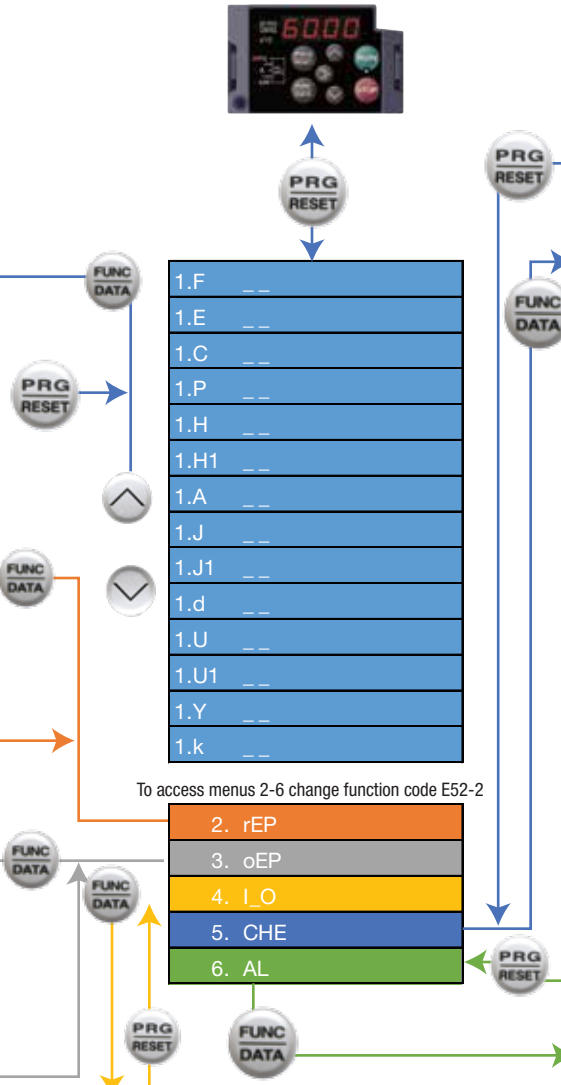

4.	I_O (I/O Check)
4_00	I/O Signals on the Control Card Terminals
4_01	I/O Signals on the Control Card Terminals under Communications.
4_02	Input Voltage on Terminal 12
4_03	Input Current on Terminal C1
4_04	Output Voltage on Terminal FMV
4_05	Output Voltage on Terminal FM2
4_06	Output Frequency on Terminal FMP
4_07	Input Voltage on Terminal C1
4_08	Output Current on Terminal FMI
4_09	Output Current on Terminal FM2
4_24	Customizable Logic Timer

5.	CHE (Maintenance Info)
5_00	Accumulated Run Time
5_01	DC Link Bus Voltage
5_03	Max Temperature of Heat Sink
5_04	Max Effectice Current
5_05	Capacitance of the DC Link Bus Capacitance
5_06	Accumutated Run Time of Electrolytic Capacitors on the PCB
5_07	Accumulated Run Time of Cooling Fan
5_08	Number of Starts (Drive)
5_09	Input Watt-Hour
5_10	Input Watt-Hour Data

6.	AL (Alarm Info)
6_00	Output Frequency
6_01	Output Current
6_02	Output Voltage
6_03	Calculated Torque
6_04	Reference Frequency
6_05	Rotational Ditection
6_06	Running Status
6_07	Accumulated Running Time
6_08	Number of Startups
6_09	DC Link Bus Voltage
6_10	Temperature Inside the Inverter
6_11	Max. Temperature of Heat Sink
6_12	Terminal I/O Status
6_13	Terminal Input Signal Status in HEX
6_14	Terminal Output Status in Hex
6_15	Number of Consecutice Occurrces
6_16	Overlapping Alarm 1
6_17	Overlapping Alarm 2
6_18	Communication Terminal Status I/O
6_19	Communication Terminal Status Input
6_20	Communication Terminal Status Output
6_21	Sub-Code
6_22	Running Status 2
6_23	Detected Speed
6_24	Running Status 3
6_25	Multiple Alarm Sub-Code